

The product using material and processing must conform to the "WL-PZ-001"HSF technical standard control requirements

RoHS

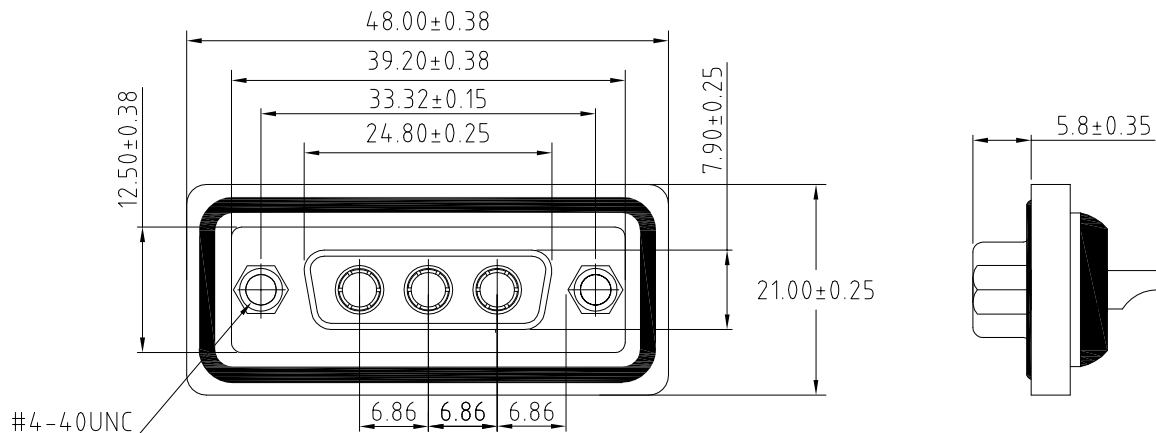

NOTE:

- 1.MATERIALS AND FINISH
  - 1-1 SHELL : STEEL MATERIAL, FRONT NICKEL FINISHED, BACK SHELL TIN FINISHED.
  - 1-2 INSULATOR: PBT THERMOPLASTIC,BLACK, 30% GLASS FILLED,UL 94V-0 RATED.
  - 1-3 CONTACT MATERIAL : BRASS CONTACT FINISH : FULL GOLD FLASH
- 2.ELECTRICAL CHARACTERISTICS
  - 2-1 CONTACT CURRENT RATING : 10/20/30/40AMPS
  - 2-2 CONTACT RESISTANCE : 2.7 MILLIOHMS MAX.
  - 2-3 DIELECTRIC WITHSTANDING VOLTAGE : 1000 V AC MIN.
  - 2-4 INSULATION RESISTANCE : 5000 MEGAOHMS MIN.
- 3.TEMPERATURE RATING: -55°~+125°.
- 4.P/N:

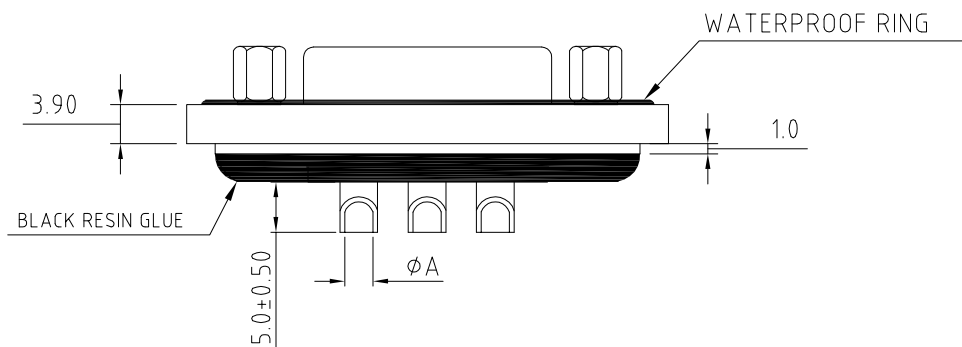

P/N	Current Rating	Dimension
		φ A
WLDBF0-034AA4195	40 AMPS	φ3.75
WLDBF0-034AA3195	30 AMPS	φ3.3
WLDBF0-034AA2195	20 AMPS	φ2.8
WLDBF0-034AA1195	10 AMPS	φ1.7

REV.	REVISION RECORD	DATE		GENERAL TOLERANCES		SCALE: 1:1	NAME	DATE	PART.NO:	DWG.NO:	
AO	NEW RELEASE	22.10.28		LINEAR	ANGLES	1:1	Wang_jr	22.10.28	WLDBF0-034AAX195	ENDE05	
			0.0±0.35	X'REF±6'	APPROVED	Han_Gao	22.10.28	TITLE:		REV: A0    SHEET: 1/1	
			0.00±0.25	X'±3'	DESIGNER	LanXuan_Hou	22.10.28	D-SUB 3W3母焊线防水 锁螺丝			
			UNIT:mm	X'X' ±2'	DRAWN						
			SIZE: A4	0.000±0.10							