

The product using material and processing must conform to the "WL-PZ-001" HSF technical standard control requirements

RoHS

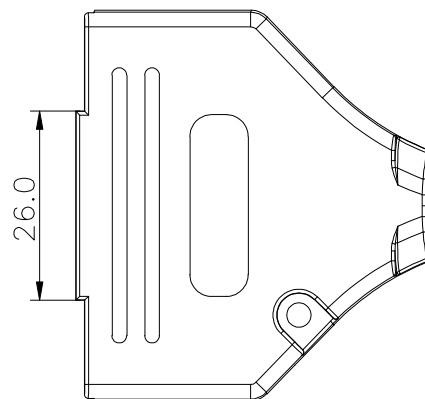
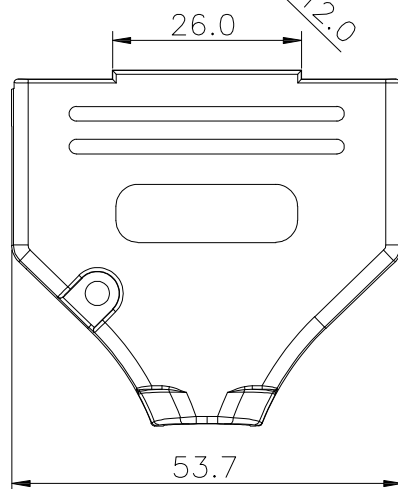
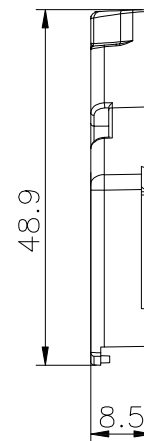
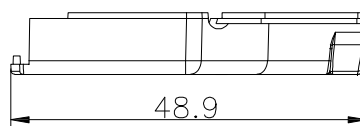
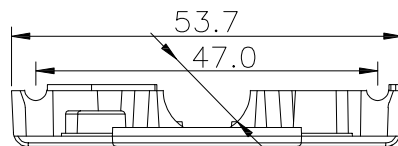
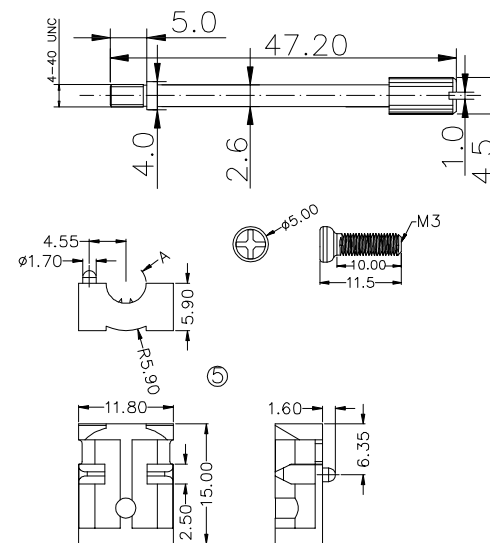
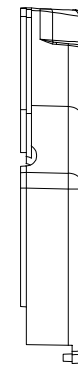
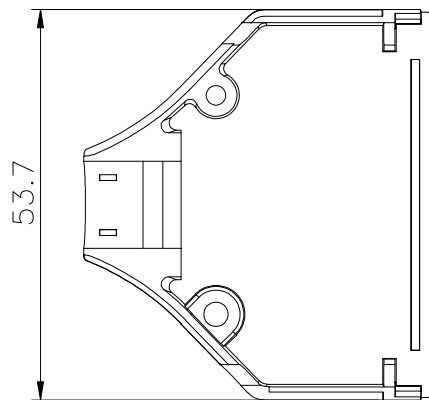
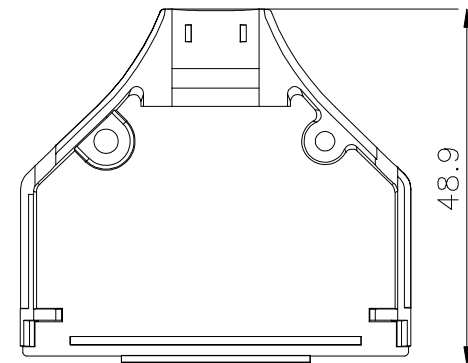

P/N	Grommets(A)
WLDBFO-254AK1191	$\phi 5.0$
WLDBFO-254AK2191	$\phi 6.0$
WLDBFO-254AK3191	$\phi 7.0$
WLDBFO-254AK4191	$\phi 8.0$
WLDBFO-254AK5191	$\phi 9.0$
WLDBFO-254AK6191	$\phi 10.0$

Item	Description	Q'TY	Material	Finished
1	Below Shell	1PCS	Zinc alloy	Nickel Plated
2	Up Shell	1PCS	Zinc alloy	Nickel Plated
3	Long Screw	2PCS	Iron	Blue Zinc Plated
4	Short Screw	2PCS	Iron	Blue Zinc Plated
5	Grommets	1SET	ABS	Black

REV.	REVISION RECORD	DATE	GENERAL TOLERANCES		SCALE:	NAME	DATE	PART.NO:	DWG.NO:
A0	NEW RELEASE	22.10.28	LINEAR	ANGLES	1:1	Wang_jr	22.10.28	WLDBFO-254AKX191	ENDE05
			0.0 \pm 0.35	X'REF \pm 6'	APPROVED	Han_Gao	22.10.28	TITLE:	 WanLian Technology Co., Ltd
			0.00 \pm 0.25	X' \pm 3'	DESIGNER	LanXuan_Hou	22.10.28	25P金属外壳	
			UNIT:mm	X'X' \pm 2'	DRAWN			REV: A0	
			SIZE: A4	0.000 \pm 0.10					