

The product using material and processing must conform to the "WI-PZ-001" HSF technical standard control requirements

RoHS

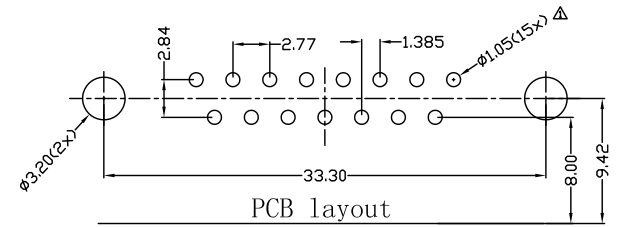
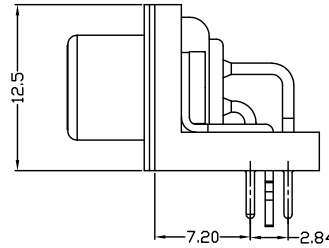
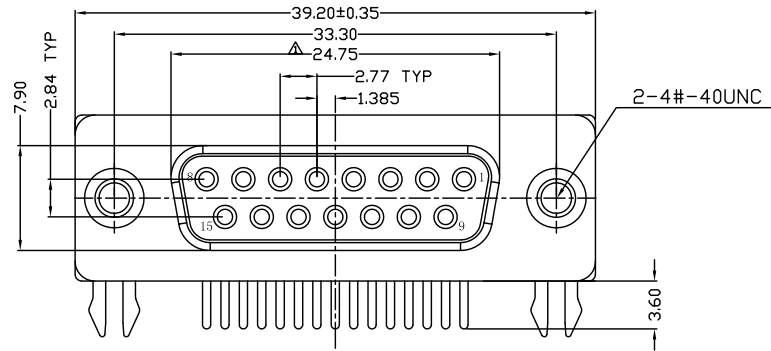

NOTE:

1. MATERIALS AND FINISH:

- 1-1. HOUSING: PBT FIBER 30% (UL94V-0)
- 1-2. CONTACTS: BRASS GOLD PLATED
- △ 1-3. SHELL: SPCC-SD NICKEL PLATED
- 1-4. RIVET: COPPER ALLOY NICKEL PLATED
- 1-5. BOARDLOCK: COPPER ALLOY NICKEL PLATED

2. ELECTRICAL PERFORMANCE:

- 2-1. CURRENT RATING: 3A
- 2-2. VOLTAGE RATING: 300V AC MAX
- 2-3. CONTACT RESISTANCE: 30mΩ MAX.
- 2-4. INSULATION RESISTANCE: 1000MΩ MIN @500VDC
- 2-5. DIELECTRIC WITHSTANDING VOLTAGE: 1000VAC/MINUTE

3. ENVIRONMENTAL PERFORMANCE:

OPERATING TEMPERATURE: -40°C~+85°C.

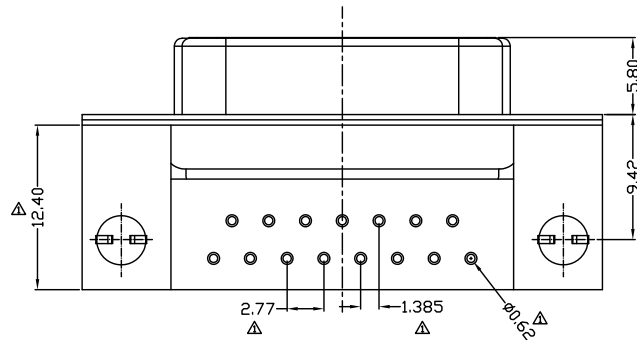

Specification Type (1:2)

A	B	C

P/N:
W L D B F 9 - 1 5 1 1 X X 0 7 5

Number of Contact ——— 15

Contact Type ——— 1 1 X X

Plating Contact ——— 0 7 5

SCREW
A: Specification Type A
B: Specification Type B
C: Specification Type C

Housing color
A: Black
K: White

REV.	REVISION RECORD	DATE	GENERAL TOLERANCES		SCALE:	NAME	DATE	PART.NO:	DWG.NO:	 WanLian Technology Co., Ltd
A0	NEW RELEASE	22.10.28	 LINEAR 0.00±0.25	 ANGLES X°REF±6°	1:1	Wang_jr	23.07.20	WLDBF9-1511AC075	ENDE05	
A1	更新图纸	23.07.20			UNIT:mm 0.00±0.10	X°X'±2°	CHECK	Ou_jian	23.07.20	
			SIZE: A4				DRAWN	LanXuan_Hou	23.07.20	