

The product using material and processing must conform to the "WI-PZ-001"HSF technical standard control requirements

ROHS

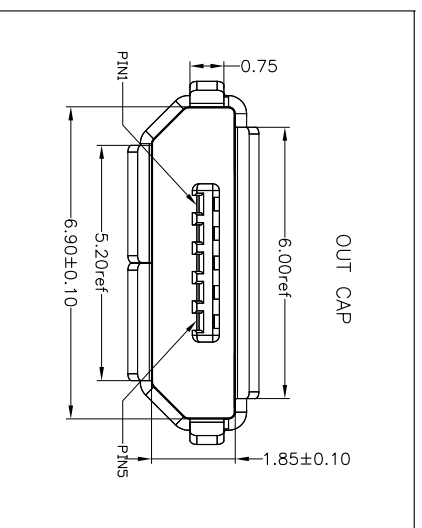
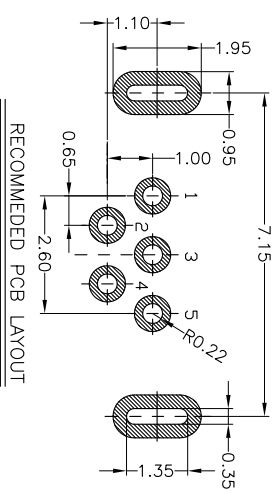
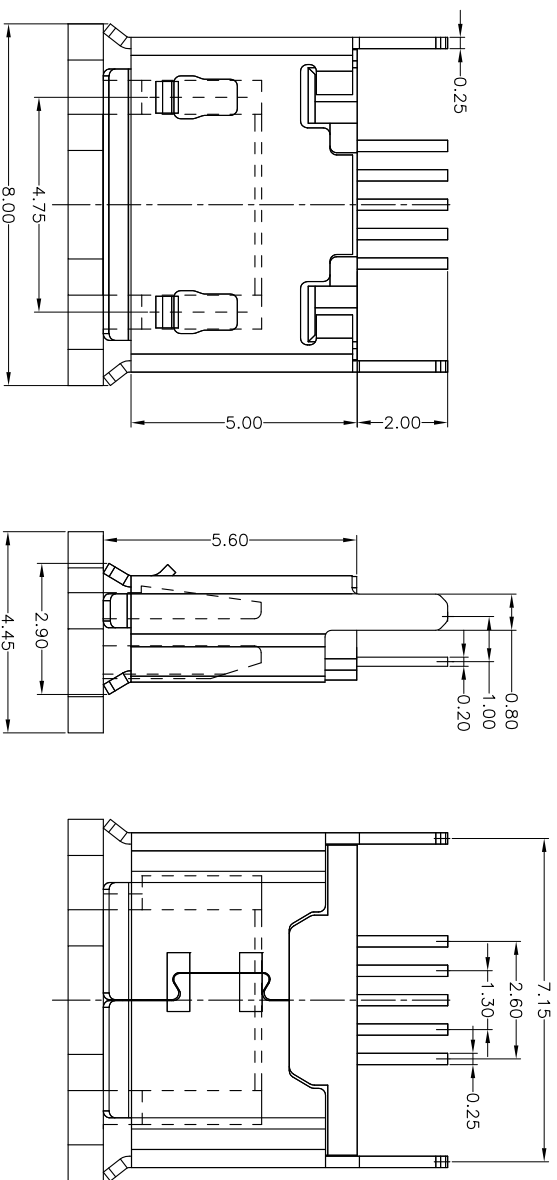

PIN NUMBER	SIGNAL NAME
1	VBUS
2	D-
3	D+
4	ID
5	GND

NO.	DESCRIPTION	QTY	MATERIAL	FINISH
3	SHELL	1	STAINLESS STEEL	Sn Plating
2	CONTACTS	1	COPPER ALLOY	Au Gold Flash
1	HOUSING	1	LCP UL94V-0	BLACK

NOTE:
 1.MECHANICAL PERFORMANCE:
 1-1.INSERTION FORCE: 3.57kgf MAX
 1-2.REMOVAL FORCE: 0.8kgf MIN
 1-3.DURABILITY: 5000 CYCLES.
 2.ELECTRICAL PERFORMANCE:
 2-1.CURRENT RATING:1A
 2-2.VOLTAGE RATING:5V MAX
 2-3.CONTACT RESISTANCE: 30m Ohm MAX.
 2-4.INSULATION RESISTANCE: 100MΩ MIN
 2-5.DIELECTRIC WITHSTANDING VOLTAGE:
 100V AC MIN
 3.ENVIRONMENTAL PERFORMANCE:
 OPERATING TEMPERATURE: -30°C~+85°C.
 PACKAGE SPEC: REEL 1000PCS

REV.	REVISION RECORD	DATE	SCALE:	NAME	DATE	PART. NO.:	DWG. NO.:
A0	NEW RELEASE	21.01.13	1:1	Wang_jr	23.05.22	WLM2FO-0511A7017	ENDE05
A1	更新图纸	23.05.22	1:1	Ou_jian	23.05.22		
GENERAL TOLERANCES		SCALE: 1:1		DATE		DWG. NO.:	
LINEAR		APPROVED		NAME		PART. NO.:	
ANGLES		DESIGNER		DATE		DWG. NO.:	
UNIT: mm		DRAWN		TITLE:		DWG. NO.:	
SIZE: A4		Hou_lanxuan		MICRO USB 5P/F B TYPE V/T		DWG. NO.:	
0.0±0.35		Ou_jian		23.05.22		ENDE05	
X°±3°		23.05.22					
X'X' ±2°							



Wanlian Technology Co., Ltd

REV: A1 SHEET: 1/1