

The product using material and processing must conform to the "WL-PZ-001"HSF technical standard control requirements

RoHS

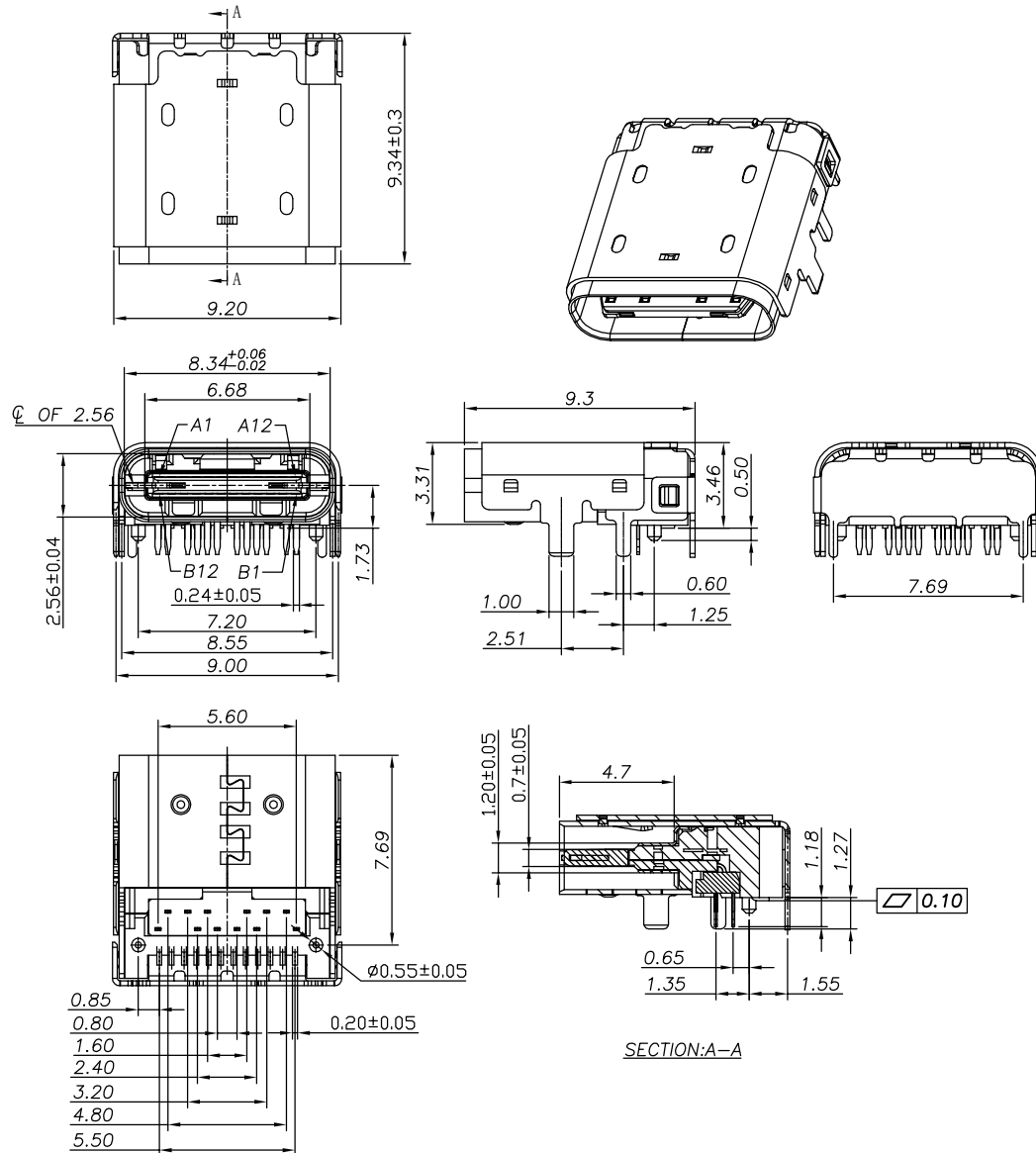

NOTE:

- 1.MATERIAL SPECIFICATION:
  - 1.HOUSING:LCP COLOR SEE TABLE 1,UL94 V-0.
  - 2.CONTACTS:COPPER ALLOY(C1814)
  - 3.MID PLATE&SPRING: STAINLESS STEEL(SUS301)
  - 4.FRONT SHELL&COVER: STAINLESS STEEL(SUS304)
- 2.PLATING SPECIFICATION:
  - 2-1.CONTACTS:
    - Ni 50u" MIN. UNDER PLATED OVER ALL.
    - Au PLATED ON THE FUNCTIONAL AREA OF CONTACT.
    - (GOLD PLATING THICKNESS FOLLOW THE P/N)
    - PLATING SPECIFICATIONS OF THE SOLDER AREA FOLLOW THE P/N
  - 2-2.FRONT SHELL & COVER:
    - Ni 30u" MIN. UNDER PLATED OVER ALL.
  - 2-3.MID PLATE & EMI SPRING:
    - CLEAR ONLY
- 3.MECHANICAL PERFORMANCE,
  - 3-1.INSERTION FORCE: 0.5~2.0kgf.
  - 3-2.REMOVAL FORCE: 0.8kgf~2.0kgf.
  - 3-3.DURABILITY: 10000 CYCLES.
- 4.ELECTRICAL PERFORMANCE,
  - 4-1. CURRENT RATING:3.0A  
VOLTAGE RATING:5.0V
  - 4-2. LLCR:
    - VBUS & GND PINS AND OTHER PINS: 40mΩ/PIN MAX.
    - SHIELD: 50mΩ/MAX.
    - LLCR MAX. CHANGE OF ALL PINS: 10mΩ.
  - 4-3.INSULATION RESISTANCE: 100MΩ MIN
  - 4-4.DIELECTRIC WITHSTAND VOLTAGE,AC 100V FOR 1 MINUTE.
5. ENVIRONMENTAL PERFORMANCE:
  - OPERATING TEMPERATURE: -25°C~+85°C.
- 6.IR REFLOW:
  - THE PEAK TEMPERATURE ON THE BOARD SHALL BE MAINTAINED FOR 10 SECONDS AT 260°C.

REV.	REVISION RECORD	DATE	GENERAL TOLERANCES		SCALE:	NAME	DATE	PART.NO:	DWG.NO:	
A0	NEW RELEASE	21.11.17	LINEAR	ANGLES	1:1	Wang_jr	21.11.17	WL74F9-243XX0046	ENDE05	
			0.0±0.35	X°REF±6°	APPROVED	Han_Gao	21.11.17	TITLE: TYPE C 24P/F R/A DIP+SMT(L=9.34mm)	REV: A0	
			0.00±0.25	X'±3°	DESIGNER	Zijun_Huang	21.11.17			SHEET: 1/3
			0.000±0.10	X''±2°	DRAWN					



The product using material and processing must conform to the "WL-PZ-001"HSF technical standard control requirements

RoHS

USB TYPE-C PIN ASSIGNMENTS

PIN NUMBER	SIGNAL NAME	PIN NUMBER	SIGNAL NAME
A1	GND	B12	GND
A2	SSTXp1	B11	SSRXp1
A3	SSTXn1	B10	SSRXn1
A4	Vbus	B9	Vbus
A5	CC1	B8	SBU2
A6	Dp1	B7	Dn2
A7	Dn1	B6	Dp2
A8	SBU1	B5	CC2
A9	Vbus	B4	Vbus
A10	SSRXn2	B3	SSTXn2
A11	SSRXp2	B2	SSTXp2
A12	GND	B1	GND

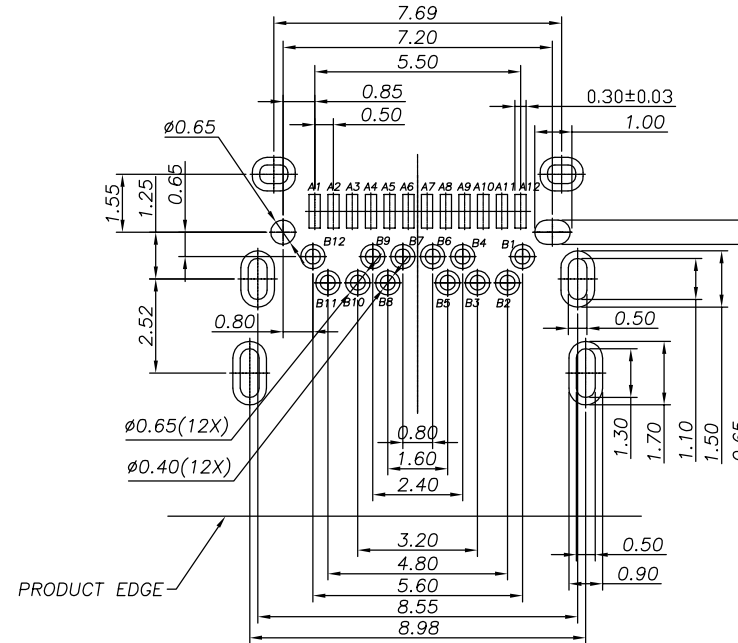

SCALE 1.5:1

RECOMMENDED PCB LAYOUT(TOP VIEW)  
THICKNESS 1.0 MM;DEFAULT TOLERANCE: ±0.05

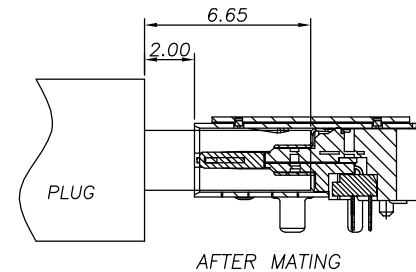

P/N:

WLT4F9-24 3 X X 0 046

Plating Contact

COLOR:  
A-BLACK

1-G/F

2-Au 3u"

3-AU 5u"

5-Au 15u"

6-Au 30u"

REV.	REVISION RECORD	DATE	GENERAL TOLERANCES		SCALE:	NAME	DATE	PART.NO:	DWG.NO:
A0	NEW RELEASE	21.11.17	LINEAR	ANGLES	1:1	Wang_jr	21.11.17	WLT4F9-243XX0046	ENDE05
			0.0±0.35	X°REF±6°	APPROVED	Han_Gao	21.11.17	TITLE:	 WanLian Teconology Co., Ltd REV: A0    SHEET: 2/3
			0.00±0.25	X°±3°	DESIGNER	Zijun_Huang	21.11.17	TYPE C 24P/F R/A DIP+SMT(L=9.34mm)	
			0.000±0.10	X°X' ±2°	DRAWN				

The product using material and processing must conform to the "WL-PZ-001"HSF technical standard control requirements

RoHS

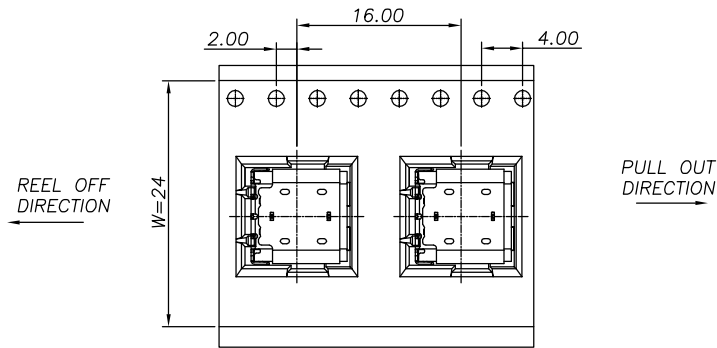
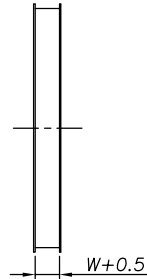
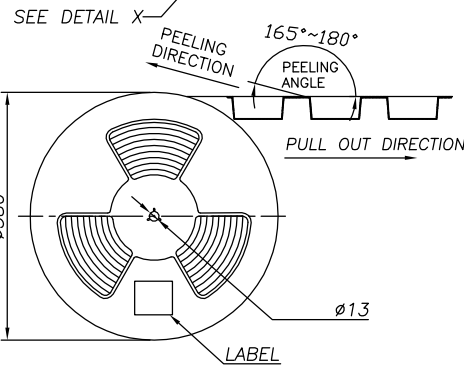
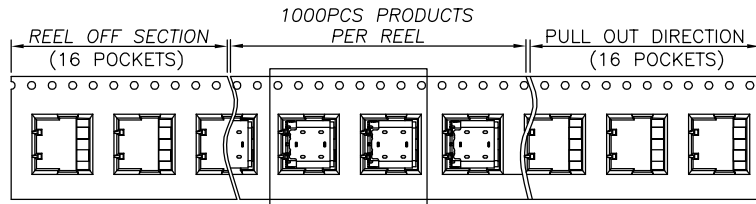

DETAIL X  
SCALE 2:1

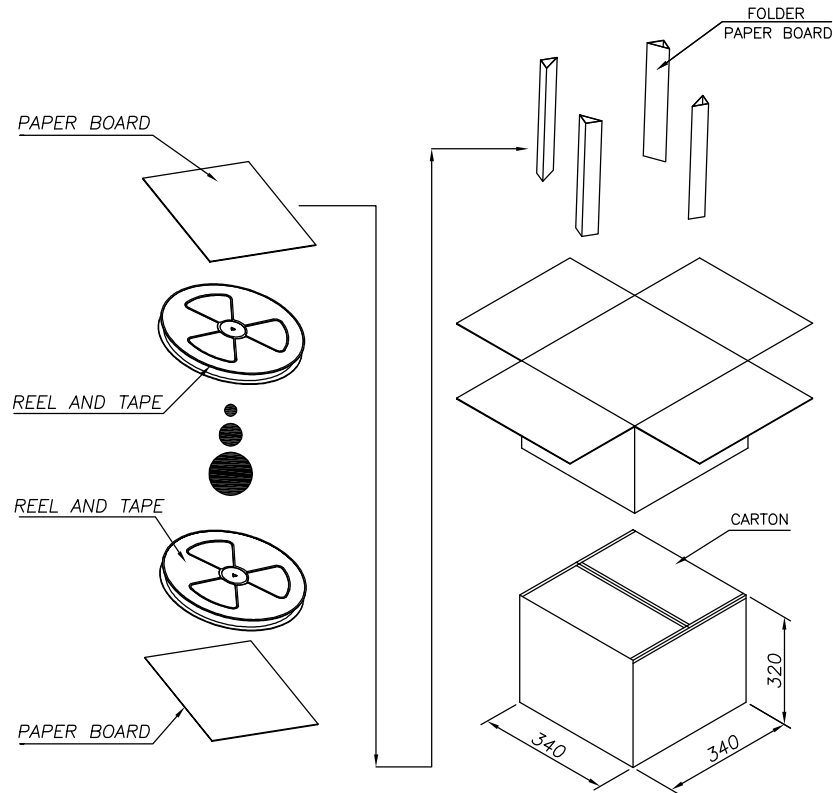

	REEL	CARTON
CONNECTOR (PCS)	1000	10000

REV.	REVISION RECORD	DATE		GENERAL TOLERANCES		SCALE: 1:1	NAME	DATE	PART.NO:	DWG.NO:	 WanLian Teconology Co., Ltd	
A0	NEW RELEASE	21.11.17		LINEAR	ANGLES	APPROVED	Wang_jr	21.11.17	WLT4F9-243XX0046	ENDE05		
			UNIT:mm	$0.00\pm 0.25$	$X^{\circ}\pm 3^{\circ}$	DESIGNER	Han_Gao	21.11.17	TITLE: TYPE C 24P/F R/A DIP+SMT(L=9.34mm)		REV: A0	SHEET: 3/3
			SIZE: A4	$0.000\pm 0.10$	$X^{\circ}X^{\circ}\pm 2^{\circ}$	DRAWN	Zijun_Huang	21.11.17				