

PCB layout

The product using material and processing must conform to the "WI-PZ-001"HSF technical standard control requirements

CHARACTERISTICS:

- 1、RATED VOLTAGE: 250V AC CD
- 2、RATED CURRENT: 3.0AMP
- 3、CONTACT RESISTANCE: 30mΩ Max.
- 4、INSULATION RESISTANCE: 1000 MΩ MIN. 500V DC
- 5、Electric Pressure: Keeping 60 second in AC 500V/1mA
- 6、Operating temperature: -55℃~105℃
- 7、INSERTION/EXTRACTION FORCE PER CONTACT: 3.0Kg Max
0.3Kg Min.

Specification Type			
A	B	C	D
	6.00	4.80	5.80

ORDER INFORMATION

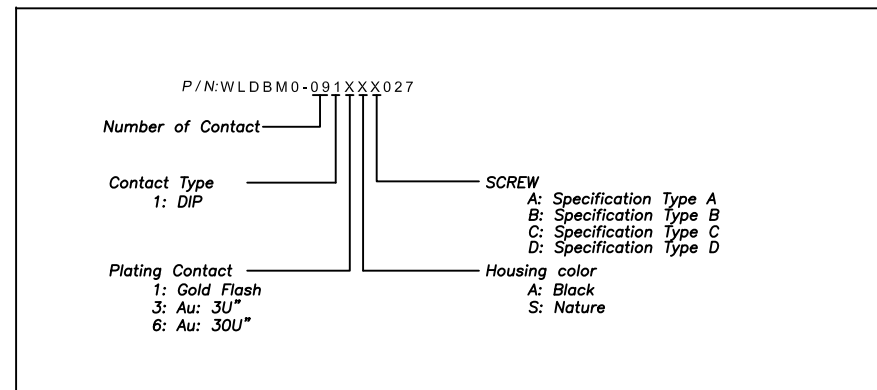

REV.	REVISION RECORD	DATE		GENERAL TOLERANCES		SCALE: 1:1	NAME	DATE	PART. NO:	DWG. NO:	 WanLian Teconology Co., Ltd
A0	NEW RELEASE	21.01.13		LINEAR	ANGLES	APPROVED	Wang_jr	21.03.11	WLDBM0-091XXX027	ENDE05	
			UNIT: mm	0.00±0.25	X° ±3°	DESIGNER	Ding_Bo	21.03.11	TITLE:		REV: A0 SHEET: 1/1
			SIZE: A4	0.000±0.10	X° X'±2°	DRAWN	Ou_Jian	21.03.11	DP 09M DIP		