

The product using material and processing must conform to the "WL-PZ-001" HSF technical standard control requirements

RoHS

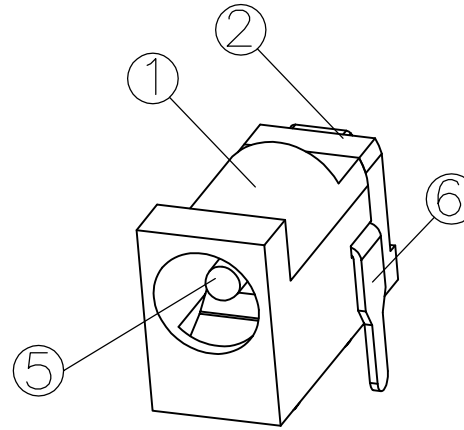
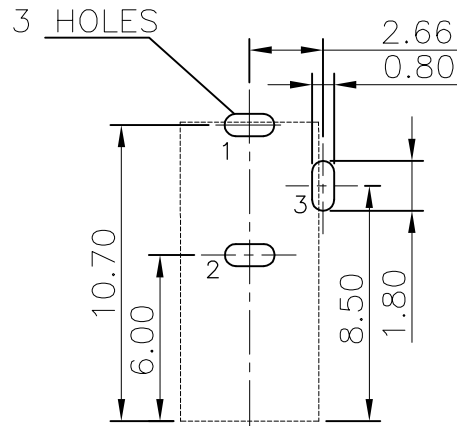

NOTE:

1.MATERIAL SPECIFICATION:

- 1-1.HOUSING:PA66 UL 94HB COLOUR:BLACK
- 1-2.COVER:PA66 UL 94HB COLOUR:BLACK
- 1-3.SPRING:PHOSPHOR BRONZE T=0.25mm
- 1-4.FLAT PIECE:BRASS T=0.30mm
- 1-5.PIN:H62 BRASS
- 1-6.CURVE PIECE:BRASS T=0.30mm

2.PLATING SPECIFICATION:

- 2-1.SPRING:
CUSN-PLATED ON CONTACT AREA.
- 2-2.FLAT PIECE:
CUSN-PLATED ON CONTACT AREA.
- 2-3.PIN:
CUSN-PLATED ON CONTACT AREA.
- 2-4.CURVE PIECE:
CUSN-PLATED ON CONTACT AREA.

3.MECHANICAL PERFORMANCE:

- 3-1.LIFE TEST: 5000 CYCLES MIN.

4.ELECTRICAL PERFORMANCE:

- 4-1.RATING CURRENT:0.5A AC
- 4-2.RATING VOLTAGE:30V AC
- 4-3.CONTACT RESISTANCE: 30mΩ MAX;
- 4-4.INSULATION RESISTANCE:100MΩ MIN
- 4-5.WITHSTANDING VOLTAGE: 500V AC
- 5.OPERATION TEMPERATURE RANGE:-20°C~+85°C
- 6.P/N:

T:1.6 Dimensions of PC board holes

Tolerance : ±0.1(Printed-top view)

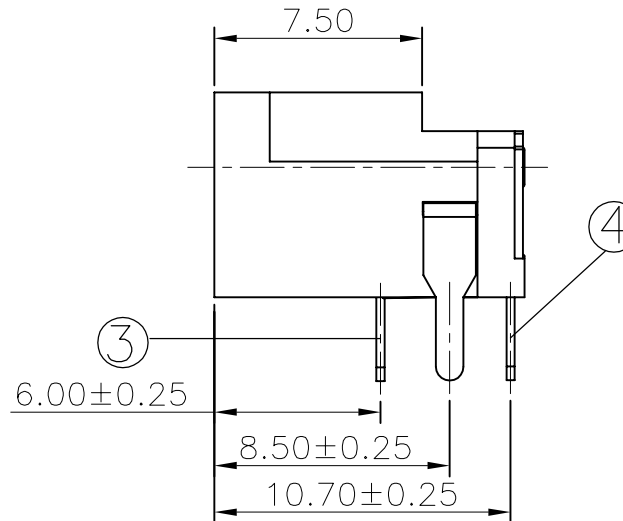
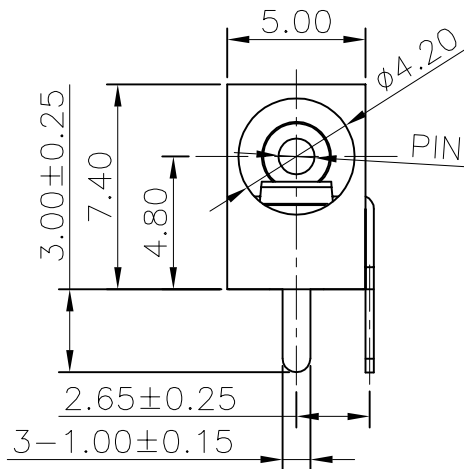

WLDCF9-03 X 1 1 0 059

PLATED:
1.G/F
7.SN
8.AG

HOUSING:
1.PA66 BLACK

CAT. NO.	PIN	SCHEMATIC
	φ1.65	

REV.	REVISION RECORD	DATE	GENERAL TOLERANCES		SCALE:	NAME	DATE	PART.NO:	DWG.NO:	
A0	NEW RELEASE	21.01.13	LINEAR	ANGLES	1:1	Wang_jr	21.01.13	WLDCF9-03X110059	ENDE05	
			0.0±0.35	X'REF±6'		Han_Gao	21.01.13	TITLE:		
			UNIT:mm	X'±3'		Zijun_Huang	21.01.13	DC JACK		
			SIZE: A4	0.000±0.10	X'X' ±2'					

WanLian Teconology Co., Ltd

REV: A0 SHEET: 1/1