

The product using material and processing must conform to the "WL-PZ-001"HSF technical standard control requirements

RoHS

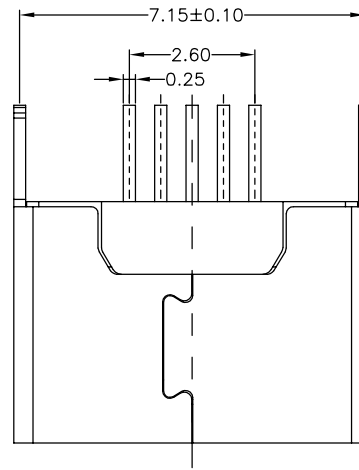
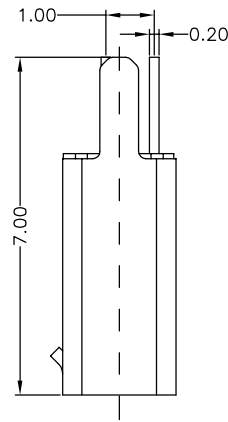
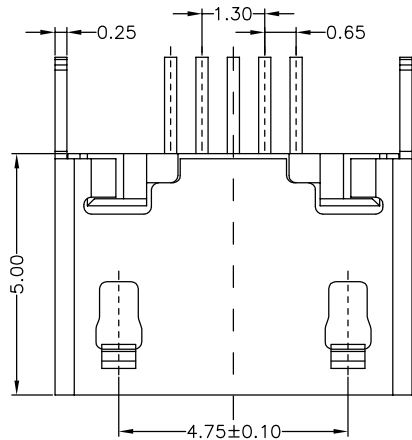

NOTE:

1.MATERIAL SPECIFICATION:

- 1-1.HOUSING:LCP BLACK UL94V-0
- 1-2.CONTACTS:COPPER ALLOY(C5191-H).
- 1-3.SHELL: STAINLESS STEEL.

2.PLATING SPECIFICATION:

- 2-1.CONTACTS:
Ni 50u" MIN. UNDER PLATED OVER ALL.
Au PLATED ON THE FUNCTIONAL AREA OF CONTACT.
- 2-2. SHELL:
Ni /SN 30u" MIN. UNDER PLATED OVER ALL.

3.MECHANICAL PERFORMANCE:

- 3-1.INSERTION FORCE: 3.57kgf MAX
- 3-2.REMOVAL FORCE: 0.8kgf MIN
- 3-3.DURABILITY: 10000 CYCLES.

4.ELECTRICAL PERFORMANCE:

- 4-1.CURRENT RATING:1.5A
- 4-2.VOLTAGE RATING:5V MAX
- 4-3.CONTACT RESISTANCE: 30m Ohm MAX.
- 4-4.INSULATION RESISTANCE: 100MΩ MIN
- 4-5.DIELECTRIC WITHSTANDING VOLTAGE: 100V AC MIN

5.ENVIRONMENTAL PERFORMANCE:

- OPERATING TEMPERATURE: -30°C~+85°C.
- PACKAGE SPEC: REEL

PART NO.:

WLM2F0-051 X X X 043

PLATING:

- 1-G/F
- 2-Au 3u"
- 5-Au 15u"
- 6-Au 30u"

SHELL:

- 7-SN
- 9-NI

COLOUR:

A-BLACK

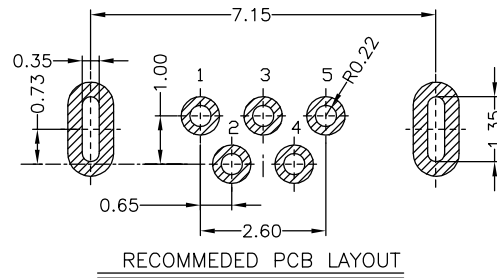
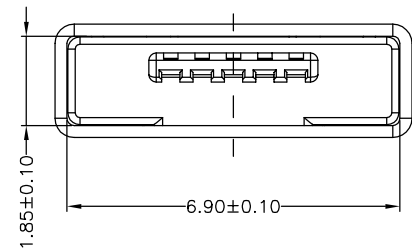

REV.	REVISION RECORD	DATE	GENERAL TOLERANCES		SCALE:	NAME	DATE	PART.NO:	DWG.NO:
A0	NEW RELEASE	21.01.13	LINEAR	ANGLES	1:1	Wang_jr	21.01.13	WLM2F0-051XXX043	ENDE05
			0.0±0.35	X°REF±6°	APPROVED	Ding_bo	21.01.13	TITLE: MICRO 5P/F AB TYPE 180° DIP 2.0	REV: A0
			0.00±0.25	X°±3°	DESIGNER	Ou_jian	21.01.13		
			0.000±0.10	X°X' ±2°	DRAWN				
			UNIT:mm						SHEET: 1/1



WanLian Teconology Co., Ltd