

The product using material and processing must conform to the "WI-PZ-001"HSF technical standard control requirements

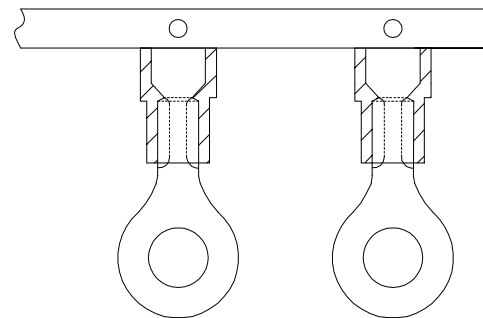
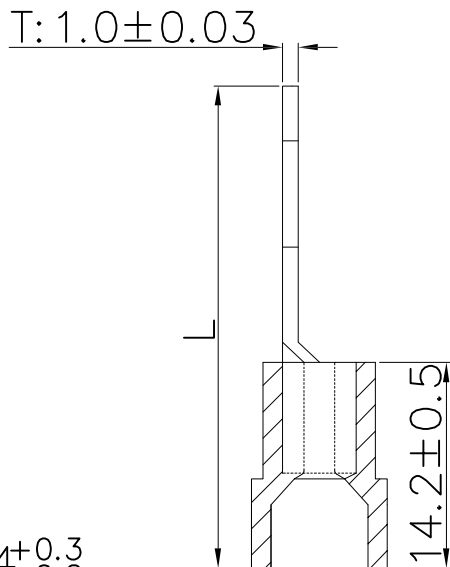
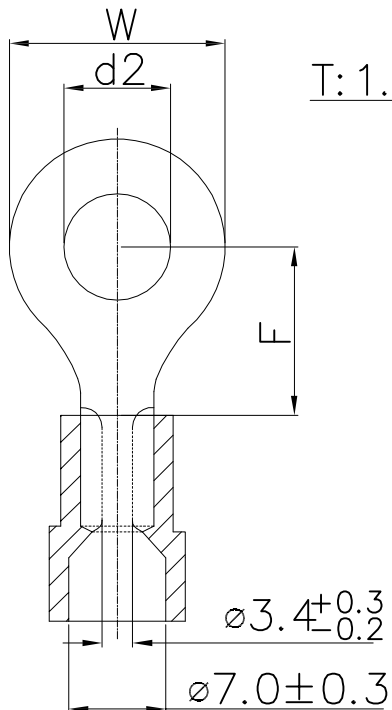

金属连打型

端子材质: 紫铜	表面处理: 镀锡
塑料材质: 尼龙	镀层厚度: 2.5um-5um
绝缘套颜色: 黄色	镀层耐温: 120°/2小时
绝缘护套温度: 105C	最大电流: 48A

Item NO. 料号	螺栓规格		mm/inch主要尺寸		
	Stud Size	d2±0.2	W±0.3	F±0.3	L±0.5
WLRVN5-032030181-149	#4	3.2(.126)	7.2(.283)	5.9(.232)	22.7(0.894)
WLRVN5-022030182-149	#6	3.7(.146)	7.2(.283)	5.9(.232)	22.7(0.894)
WLRVN5-042030183-149	#8	4.3(.169)	7.2(.283)	5.9(.232)	22.7(0.894)
WLRVN5-042030184-149	#8	4.3(.169)	9.5(.374)	8.3(.326)	26.3(1.035)
WLRVN5-052030185-149	#10	5.5(.216)	9.5(.374)	8.3(.326)	26.3(1.035)
WLRVN5-062030186-149	1/4	6.4(.252)	12.0(.472)	11.0(.433)	30.0(1.181)
WLRVN5-082030187-149	5/16	8.4(.331)	15.0(.590)	13.7(.539)	34.5(1.358)
WLRVN5-102030188-149	3/8	10.5(.413)	15.0(.590)	13.7(.539)	34.5(1.358)

REV.	REVISION RECORD	DATE
A0	NEW RELEASE	21.10.12

	GENERAL TOLERANCES		SCALE: 1:1	NAME	DATE
	LINEAR	ANGLES	APPROVED	Wang_jr	21.10.12
	0.0±0.35	X°REF±6°	DESIGNER	Han_Gao	21.10.12
	UNIT:mm	0.00±0.25	X'±3'	DRAWN	Zijun_Huang
SIZE: A4	0.000±0.10	X'X' ±2'			

PART.NO:	DWG.NO:
WLRVN5-XX2030XXX-149	ENDE05
TITLE:	
尼龙绝缘护套圆型端子	



REV: A0	SHEET: 1/1
---------	------------