

The product using material and processing must conform to the "WL-PZ-001"HSF technical standard control requirements

RoHS

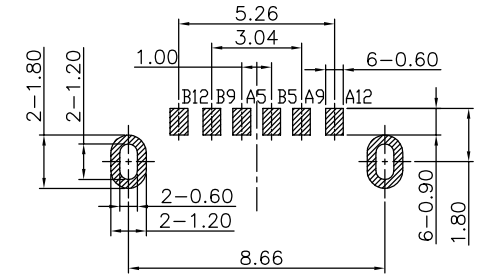
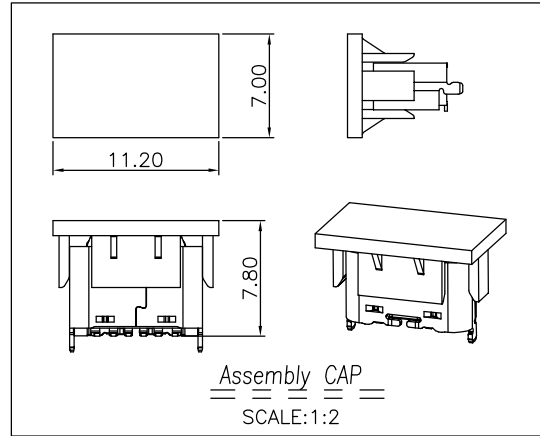
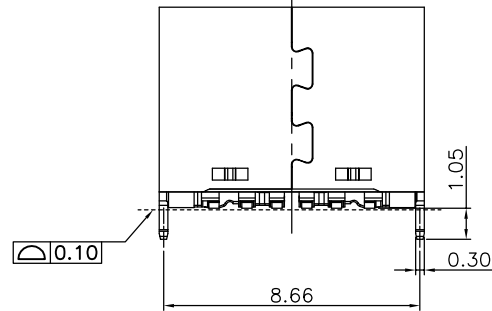
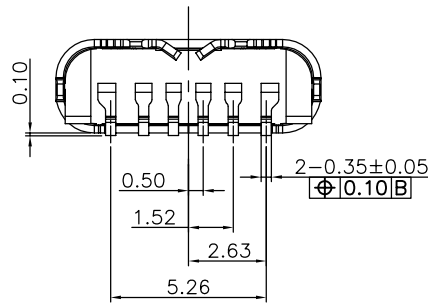
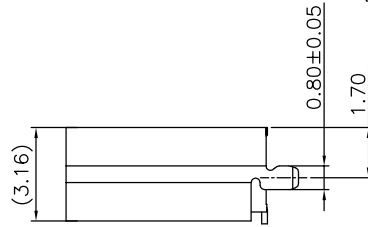
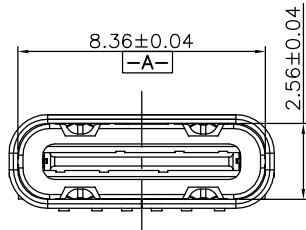
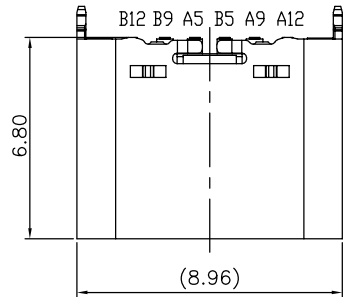

P.C.B LAYOUT VIEW

TOLERANCE ±0.05

NOTE:

- 1.MATERIAL SPECIFICATION:
 - 1-1.HOUSING:LCP BLACK UL94V-0
 - 1-2.CONTACTS:COPPER ALLOY
 - 1-3.MID PLATE: STAINLESS STEEL
 - 1-4.SHELL: STAINLESS STEEL
- 2.PLATING SPECIFICATION:
 - 2-1.CONTACTS:
 - Ni 50u" MIN. UNDER PLATED OVER ALL.
 - Au PLATED ON THE FUNCTIONAL AREA OF CONTACT.
 - 2-2.MID PLATE:
 - CLEAR ONLY
 - 2-3.FRONT SHELL:
 - Ni 50u" MIN. UNDER PLATED OVER ALL.
- 3.MECHANICAL PERFORMANCE:
 - 3-1.INSERTION FORCE: 0.5~2.0kgf.
 - 3-2.REMOVAL FORCE: 0.8~2.0kgf.
 - 3-3.DURABILITY: 10000 CYCLES.
- 4.ELECTRICAL PERFORMANCE:
 - 4-1. CURRENT RATING:3.0A
 - VOLTAGE RATING:20V MAX
 - 4-2.CONTACT RESISTNACE: 30mΩ MAX
 - 4-3.INSULATION RESISTANCE: 100MΩ MIN
 - 4-4.WITHSTANDING VOLTAGE: 100V AC r.m.s.
- 5.ENVIRONMENTAL PERFORMANCE:
 - OPERATING TEMPERATURE: -40°C~+85°C.

PIN ASSIGNMENT

Pin	Signal Name	Pin	Signal Name	Pin	Signal Name	Pin	Signal Name
A1	GND	B12	GND	A7	D-	B6	D+
A2	TX1+	B11	RX1-	A8	SBU1	B5	CC2
A3	TX1-	B10	RX1+	A9	VBUS	B4	VBUS
A4	VBUS	B9	VBUS	A10	RX2-	B3	TX2+
A5	CC1	B8	SBU2	A11	RX2+	B2	TX2+
A6	D+	B7	D-	A12	GND	B1	GND

PART.NO.:
WLT2F0-06 2 X X 0 167

PLATING: — COLOUR: A-BLACK
 1-G/F
 2-Au 3u"
 5-Au 15u"
 6-Au 30u"

REV.	REVISION RECORD	DATE	UNIT:mm	GENERAL TOLERANCES		SCALE:	NAME	DATE	PART.NO:	DWG.NO:	 WanLian Teconology Co., Ltd
A0	NEW RELEASE	21.01.13		LINEAR	ANGLES	1:1	APPROVED	Wang_jr	21.01.13	WLT2F0-062XX0167	
			0.00±0.25	X°±3'		DESIGNER	Han_Gao	21.01.13	TITLE:		REV: A0
			0.000±0.10	X°X' ±2'		DRAWN	Zijun_Huang	21.01.13	TYPE C 6P/F On Board Vertical 6.8H SMT		SHEET: 1/2

The product using material and processing must conform to the "WL-PZ-001"HSF technical standard control requirements

RoHS

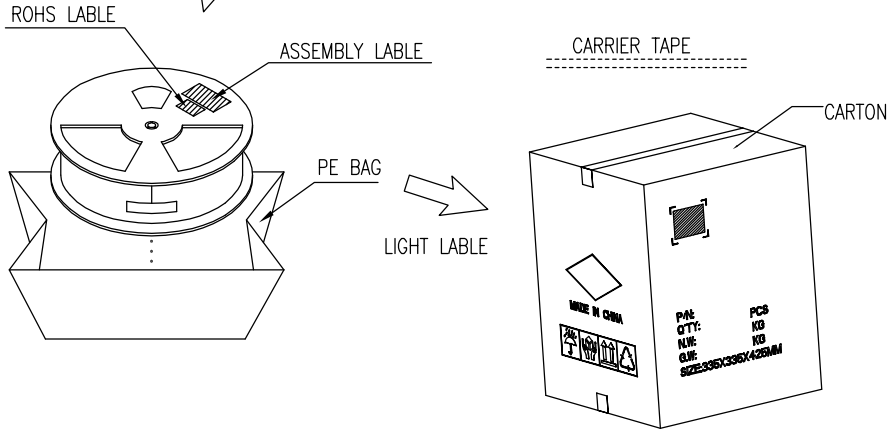
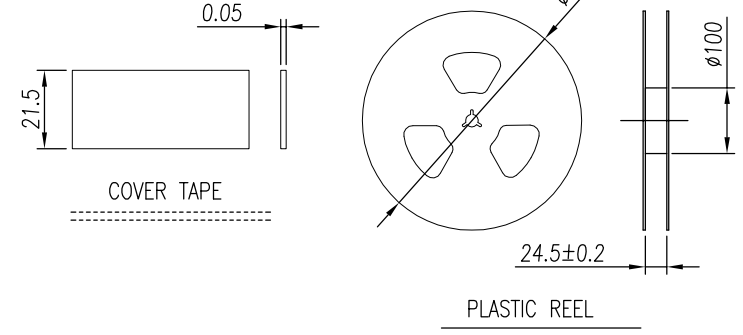
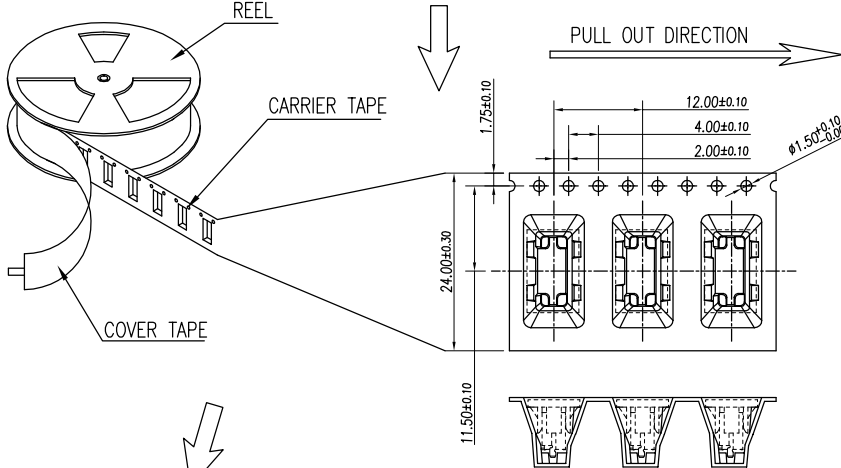
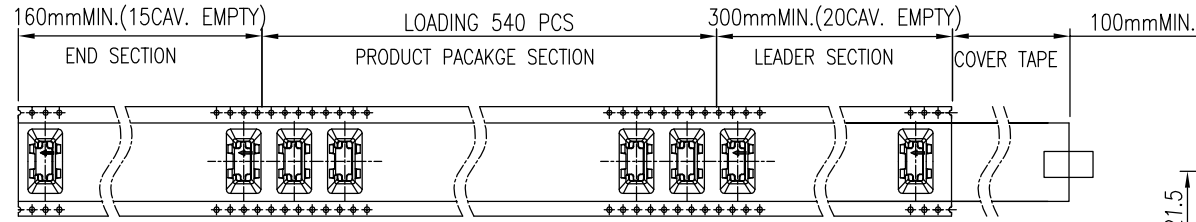

NOTES 2:

1. MATERIAL:
 - 1.1 REEL AND AXLE: PS,BLUE
 - 1.2 CARRIER TAPE: PET, LUCID
 - 1.3 COVER TAPE: PS,TRANSPARENT
 - 1.4 SHIPPING CARTON: CORRUGATED FIBER
2. DIMENSION:
 - 2.1 REEL: W=24.5, ØA=330
 - 2.2 CARRIER TAPE: T=0.50 W=24.0
 - 2.3 COVER TAPE: T=0.05 W=21.5
 - 2.4 SHIPPING CARTON: L=335mm, W=335mm, H=425mm
3. QUANTITY :
 - 3.1 PRIMAY PACKING: 540 PCS/REEL
 - 3.2 SECONARY PACKING: 10 REELS/CARTON(5400PCS/CARTON)
4. PEELING RESISTANCE: 0.1~1.3N
 - 4.1 PEELING SPEED: 300mm/minutes
 - 4.2 PEELING ANGLE: 165° ~180°

REV.	REVISION RECORD	DATE		GENERAL TOLERANCES		SCALE:	NAME	DATE	PART.NO:	DWG.NO:	 WanLian Teconology Co., Ltd
AO	NEW RELEASE	21.01.13		LINEAR	ANGLES	1:1	Wang_jr	21.01.13			
			0.0±0.35	X°REF±6'	APPROVED	Han_Gao	21.01.13	TITLE:			
			0.00±0.25	X°±3'	DESIGNER	Zijun_Huang	21.01.13	TYPE C 6P/F On Board Vertical 6.8H SMT			
			UNIT:mm	0.00±0.10	X°X' ±2'	DRAWN				REV: A0	SHEET: 2/2
			SIZE: A4								