

The product using material and processing must conform to the "WI-PZ-001"HSF technical standard control requirements

RoHS

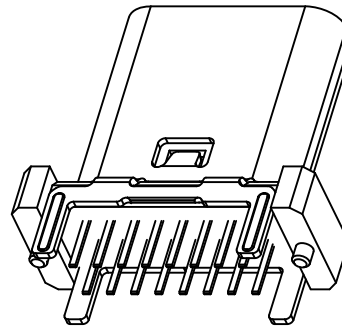
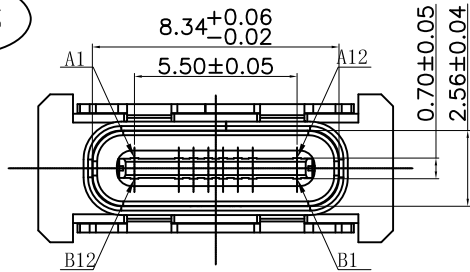

NOTE:

1.MATERIAL SPECIFICATION:

- 1-1.HOUSING:LCP BLACK UL94 V-0
- 1-2.CONTACTS:COPPER ALLOY C7025
- 1-3.MID PLATE:STAINLESS STEEL
- 1-4.SHELL: STAINLESS STEEL

2.PLATING SPECIFICATION:

- 2-1.CONTACTS:  
Ni UNDER PLATED OVER ALL.  
Au PLATED ON THE FUNCTIONAL AREA OF CONTACT.
- 2-2.MID PLATE: CLEAR ONLY
- 2-3.FRONT SHELL:Ni UNDER PLATED OVER ALL.

3.MECHANICAL PERFORMANCE:

- 3-1.INSERTION FORCE: 2.0kgf MAX
- 3-2.REMOVAL FORCE: 0.8kgf MIN
- 3-3.DURABILITY: 10000 CYCLES.

4.ELECTRICAL PERFORMANCE:

- 4-1. CURRENT RATING:5.0A  
VOLTAGE RATING:20V MAX
- 4-2. CONTACT RESISTANCE: 40m Ohm Max.
- 4-3.INSULATION RESISTANCE: 100MΩ MIN
- 4-4.WITHSTANDING VOLTAGE: 100V AC r.m.s.

5.ENVIRONMENTAL PERFORMANCE:

OPERATING TEMPERATURE: -25°C~+85°C.

6.P/N:

WLT2FO-16 1 X X 0192

PLATED: 1.G/F COLOUR: A.BLACK  
2.Au 3u"  
5.Au 15u"  
6.Au 30u"

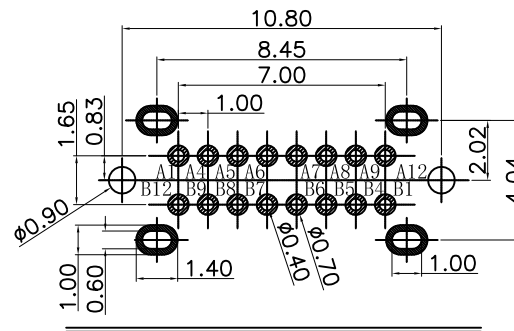
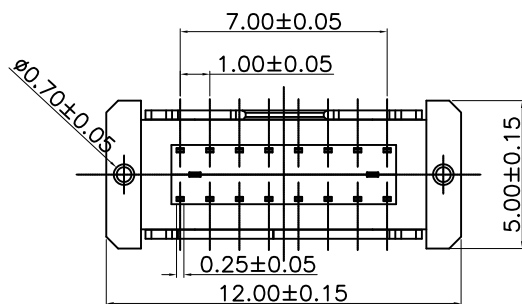
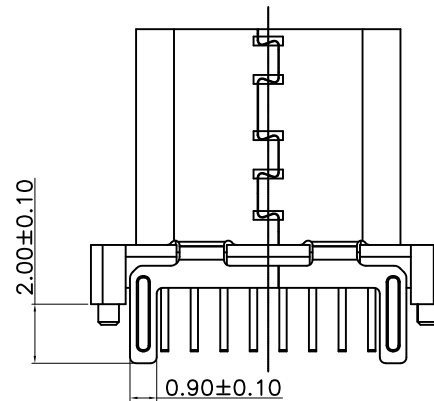
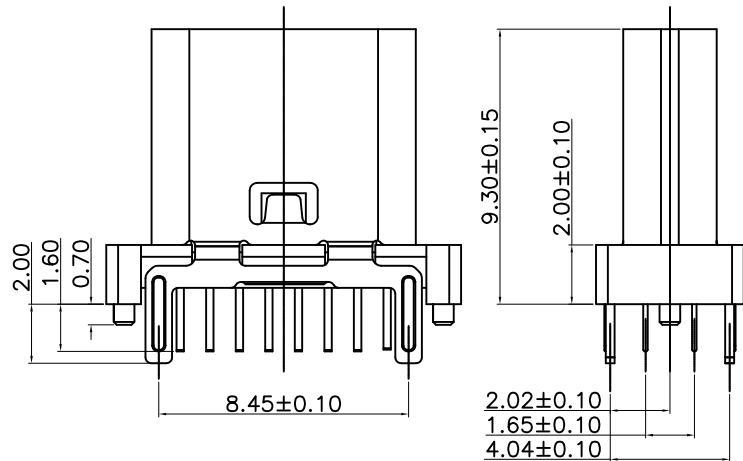

A1	A2	A3	A4	A5	A6	A7	A8	A9	A10	A11	A12
GND			VBUS	CC1	D+	D-	SBU1	VBUS			GND
GND			VBUS	SBU2	D-	D+	CC2	VBUS			GND
B12	B11	B10	B9	B8	B7	B6	B5	B4	B3	B2	B1

REV.	REVISION RECORD	DATE		GENERAL TOLERANCES		SCALE: 1:1	NAME	DATE	PART.NO:	DWG.NO:	 WanLian Teconology Co., Ltd
A0	NEW RELEASE	21.01.13		LINEAR	ANGLES	APPROVED	Wang_jr	21.01.13	WLT2FO-161XX0192	ENDE05	
			UNIT:mm	0.00±0.25	X°±3°	DESIGNER	Han_Gao	21.01.13	TITLE:		REV: A0 SHEET: 1/2
			SIZE: A4	0.000±0.10	X°X' ±2°	DRAWN	Zijun_Huang	21.01.13	Type C 16P/F 180° DIP L=9.3mm		

The product using material and processing must conform to the "WI-PZ-001" HSF technical standard control requirements

RoHS

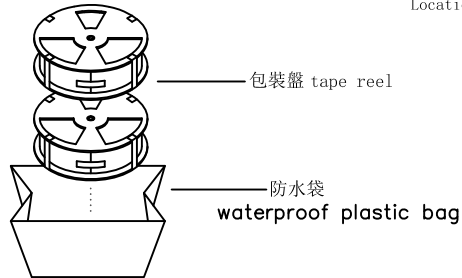
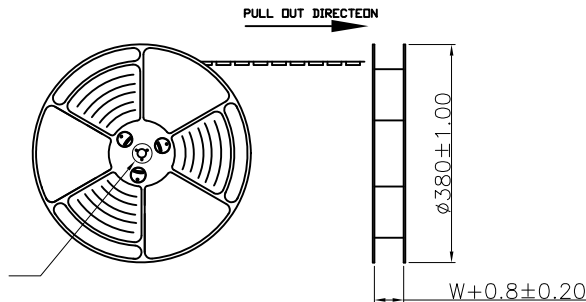

at small positioning hole of the carrier tape side.  
 標籤黏貼處 (朝捲裝包材的小定位孔一側)  
 Location of label sticking (label)

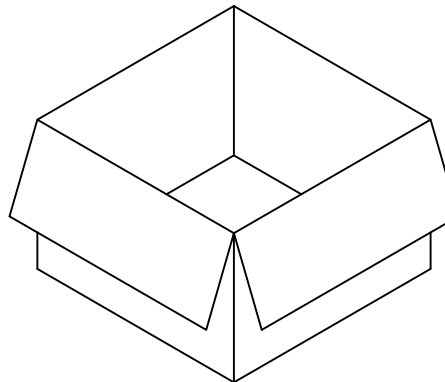
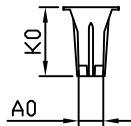
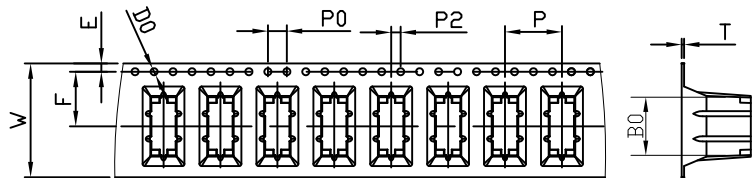
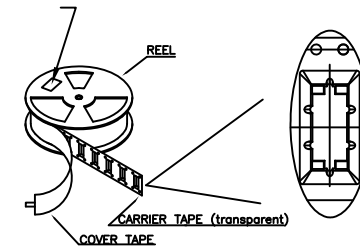

紙箱: 390mmX390mmX310mm

NOTE:

1. 每捲包裝數量及每箱裝箱數量如左下表格。  
Packing q'ty of each reel & carton as belowtable shown.
2. 將裝滿產品的卷盤放入紙箱并以膠帶封口  
Put reels in the carton and use adhesive tape to seal up.

NOTES

1. 帶子引導長度  
LEAD TAPE LENGTH  
出料方向  
PULL OUT DIRECTEON

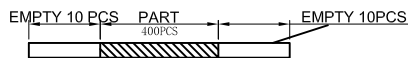

2. 上帶 剝力力為: 0.1~1.3N(10.2gf~130gf)  
PEELING OFF FORCE OF TOP TAPE: 0.1~1.3N(10.2gf~130gf)  
出貨運輸過程中一定注意:  
THIS REQUIREMENT SHOULD BE APPLIED AT SHIPMENT:  
卷帶在運輸過程中不能散開  
PEELING OFF SHOULD NOT BE ALLOWED DURING TRANSPORTATION

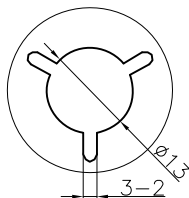
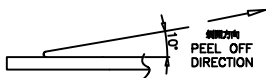

DETAIL: A  
10:1

卷帶	規格: $\phi 380\text{mm}$	包裝數量: 600PCS
紙箱	規格: 390mmX390mmX310mm	包裝數量: 10盤 (6000PCS)

W	24.00±0.3
A0	5.24±0.1
B0	12.30±0.1
K0	13.35±0.1
P	12.00±0.1
F	11.50±0.1
E	1.75±0.1
D0	1.50±0.1
P0	4.00±0.1
P2	2.00±0.1
T	0.50±0.05

REV.	REVISION RECORD	DATE	GENERAL TOLERANCES	SCALE:	NAME	DATE	PART.NO:	DWG.NO:
A0	NEW RELEASE	21.01.13		LINEAR				
			ANGLES		Han_Gao	21.01.13	TITLE: Type C 16P/F 180° DIP L=9.3mm	REV: A0
			0.0±0.35		Zijun_Huang	21.01.13		
			UNIT:mm					
			SIZE: A4					
			0.00±0.25					
			0.000±0.10					

万连科技  
WanLian Teconology Co., Ltd

REV: A0 SHEET: 2/2