

The product using material and processing must conform to the "WI-PZ-001"HSF technical standard control requirements

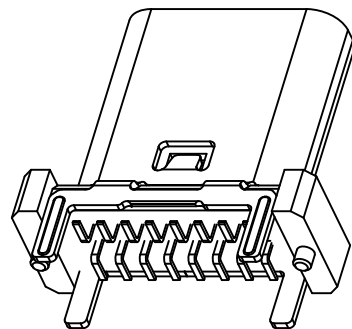
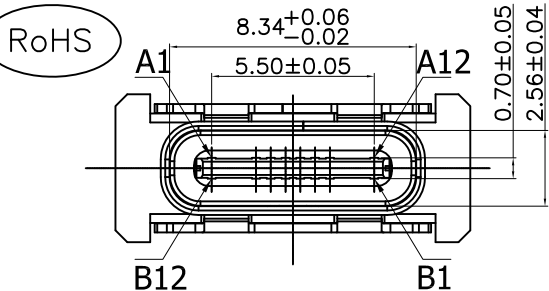

NOTE:

- 1.MATERIAL SPECIFICATION:
  - 1-1.HOUSING:LCP BLACK UL94 V-0
  - 1-2.CONTACTS:COPPER ALLOY C7025
  - 1-3.MID PLATE:STAINLESS STEEL
  - 1-4.SHELL: STAINLESS STEEL
- 2.PLATING SPECIFICATION:
  - 2-1.CONTACTS:
    - Ni UNDER PLATED OVER ALL.
    - Au PLATED ON THE FUNCTIONAL AREA OF CONTACT.
  - 2-2.MID PLATE: CLEAR ONLY
  - 2-3.FRONT SHELL:NI UNDER PLATED OVER ALL.
- 3.MECHANICAL PERFORMANCE:
  - 3-1.INSERTION FORCE: 2.0kgf MAX
  - 3-2.REMOVAL FORCE: 0.8kgf MIN
  - 3-3.DURABILITY: 10000 CYCLES.
- 4.ELECTRICAL PERFORMANCE:
  - 4-1. CURRENT RATING:5.0A  
VOLTAGE RATING:20V MAX
  - 4-2. CONTACT RESISTANCE: 40m Ohm Max.
  - 4-3.INSULATION RESISTANCE: 100MΩ MIN
  - 4-4.WITHSTANDING VOLTAGE: 100V AC r.m.s.
- 5.ENVIRONMENTAL PERFORMANCE:
 

OPERATING TEMPERATURE: -25°C~+85°C.
- 6.P/N:

WLT2F0-16 2 X X 0198

PLATED: 1-G/F      COLOUR: A-BLACK  
 2-Au 3u"      A-BLACK  
 5-Au 15u"  
 6-Au 30u"

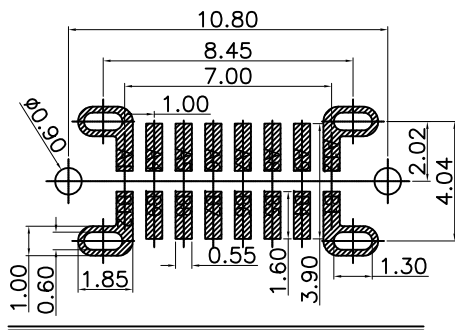
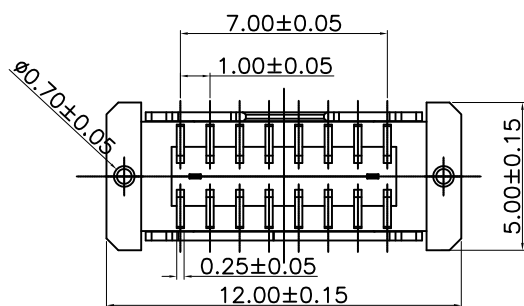
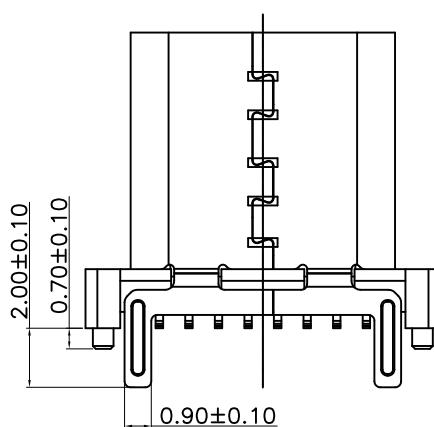
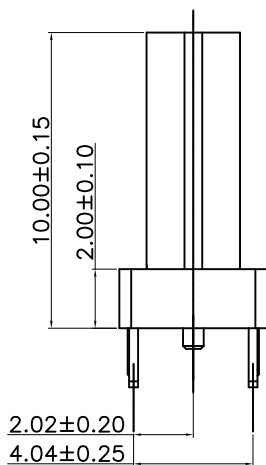
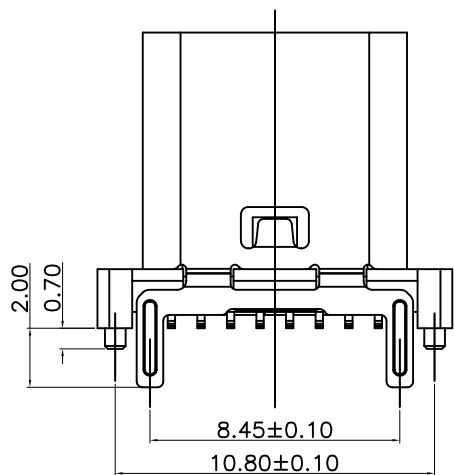

A1	A2	A3	A4	A5	A6	A7	A8	A9	A10	A11	A12
GND			VBUS	CC1	D+	D-	SBU1	VBUS			GND
GND			VBUS	SBU2	D-	D+	CC2	VBUS			GND
B12	B11	B10	B9	B8	B7	B6	B5	B4	B3	B2	B1

REV.	REVISION RECORD	DATE		GENERAL TOLERANCES		SCALE: 1:1	NAME	DATE	PART.NO: WLT2F0-162XX0198	DWG.NO: ENDE05	
A0	NEW RELEASE	21.01.13		LINEAR	ANGLES	APPROVED	Wang_jr	21.01.13			
			UNIT:mm	0.00±0.25	DESIGNER	Han_Gao	21.01.13	TITLE: Type C 16P/F 180° SMT L=10.0mm	REV: A0	SHEET: 1/2	
			SIZE: A4	0.000±0.10	DRAWN	Zijun_Huang	21.01.13				

The product using material and processing must conform to the "WI-PZ-001"HSF technical standard control requirements

RoHS

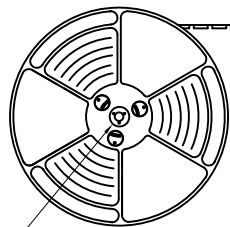

出料方向  
PULL OUT DIRECTEON

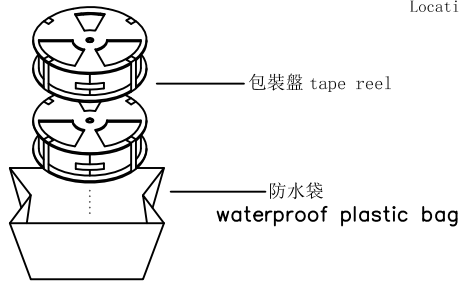
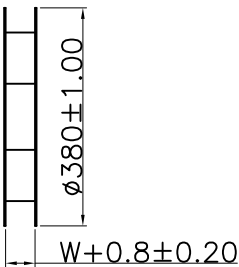

at small positioning hole of the carrier tape side.  
標籤黏貼處 (朝捲裝包材的小定位孔一側)  
Location of label sticking (label)

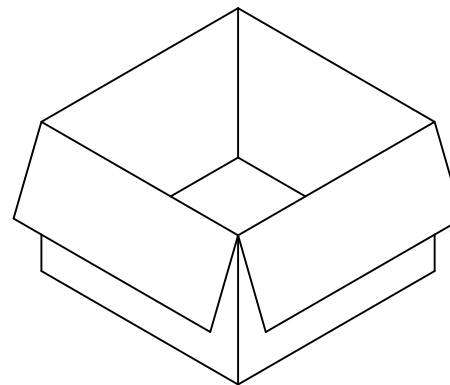
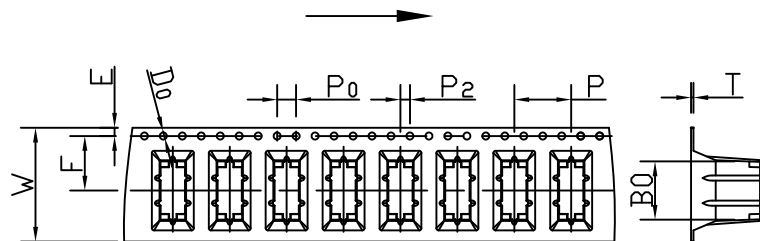
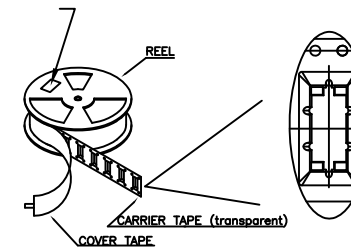

紙箱: 390mmX390mmX310mm

NOTE:

- 1.每捲包裝數量及每箱裝箱數量如左下表格。  
Packing q'ty of each reel & carton as below table shown.
- 2.將裝滿產品的卷盤放入紙箱并以膠帶封口  
Put reels in the carton and use adhesive tape to seal up.

W	24.00±0.3
A0	5.24±0.1
B0	12.30±0.1
K0	10.55±0.1
P	12.00±0.1
F	11.50±0.1
E	1.75±0.1
D0	1.50±0.1
P0	4.00±0.1
P2	2.00±0.1
T	0.50±0.05

NOTES

1.帶子引導長度  
LEAD TAPE LENGTH  
出料方向  
PULL OUT DIRECTEON



2.上帶 剝力力為: 0.1~1.3N(10.2gf~130gf)  
PEELING OFF FORCE OF TOP TAPE:0.1~1.3N(10.2gf~130gf)  
出貨\*運輸過程中一定注意:  
THIS REQUIREMENT SHOULD BE APPLIED AT SHIPMENT:  
卷帶在運輸過程中不能散開  
PEELING OFF SHOULD NOT BE ALLOWED DURING TRANSPORTATION

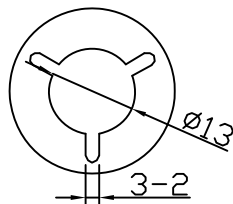
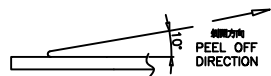

DETAIL:A  
10:1

卷帶	規格: $\phi 380\text{mm}$	包裝數量: 500PCS
紙箱	規格: 390mmX390mmX310mm	包裝數量: 10盤(5000PCS)

REV.	REVISION RECORD	DATE	GENERAL TOLERANCES		SCALE:	NAME	DATE	PART.NO:	DWG.NO:
A0	NEW RELEASE	21.01.13	LINEAR	ANGLES	1:1	Wang_jr	21.01.13	WLT2FO-162XX0198	ENDE05
			0.0±0.35	X°REF±6°	APPROVED	Han_Gao	21.01.13	TITLE: Type C 16P/F 180° SMT L=10.0mm	REV: A0 SHEET: 2/2
			UNIT:mm	X°±3°	DESIGNER	Zijun_Huang	21.01.13		
			SIZE: A4	0.000±0.10	DRAWN				

