

The product using material and processing must conform to the "WL-PZ-001"HSF technical standard control requirements

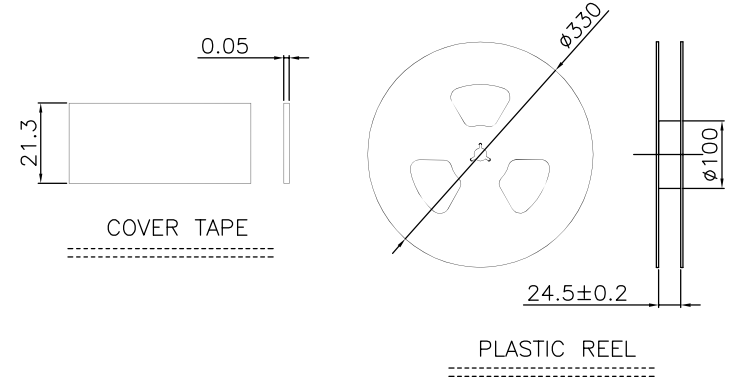

160mmMIN.(15CAV. EMPTY) LOADING 845PCS 300mmMIN.(20CAV. EMPTY) 100mmMIN. COVER TAPE

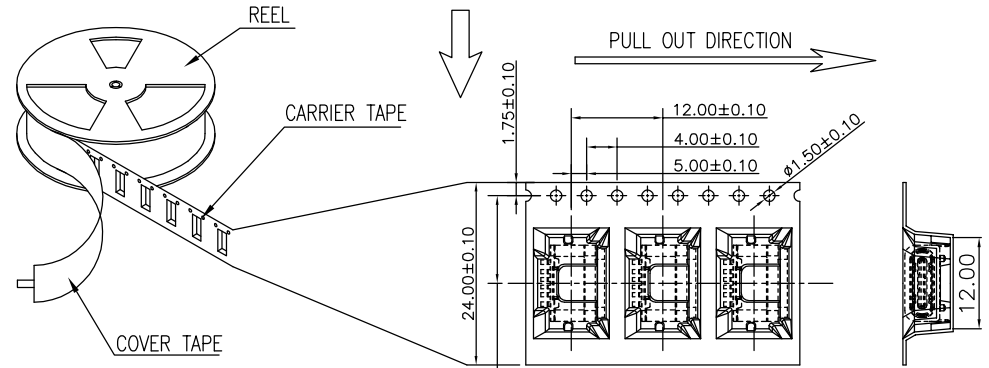
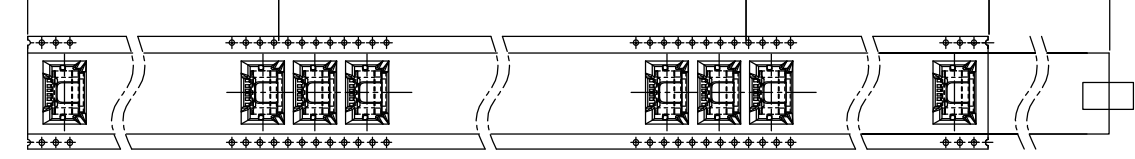

NOTES 2:

1. MATERIAL:
 - 1.1 REEL AND AXLE: PS,BLUE
 - 1.2 CARRIER TAPE: PET, LUCID
 - 1.3 COVER TAPE: PS,TRANSPARENT
 - 1.4 SHIPPING CARTON: CORRUGATED FIBER
2. DIMENSION:
 - 2.1 REEL: W=24.5, φA=330
 - 2.2 CARRIER TAPE: T=0.40 W=24.0
 - 2.3 COVER TAPE: T=0.05 W=21.3
 - 2.4 SHIPPING CARTON: L=335mm, W=335mm, H=425mm
3. QUANTITY :
 - 3.1 PRIMAY PACKING: 845PCS/REEL
 - 3.2 SECONDARY PACKING: 10 REELS/CARTON(8450PCS/CARTON)
4. PEELING RESISTANCE: 0.1~1.3N
 - 4.1 PEELING SPEED: 300mm/minutes
 - 4.2 PEELING ANGLE: 165° ~180°

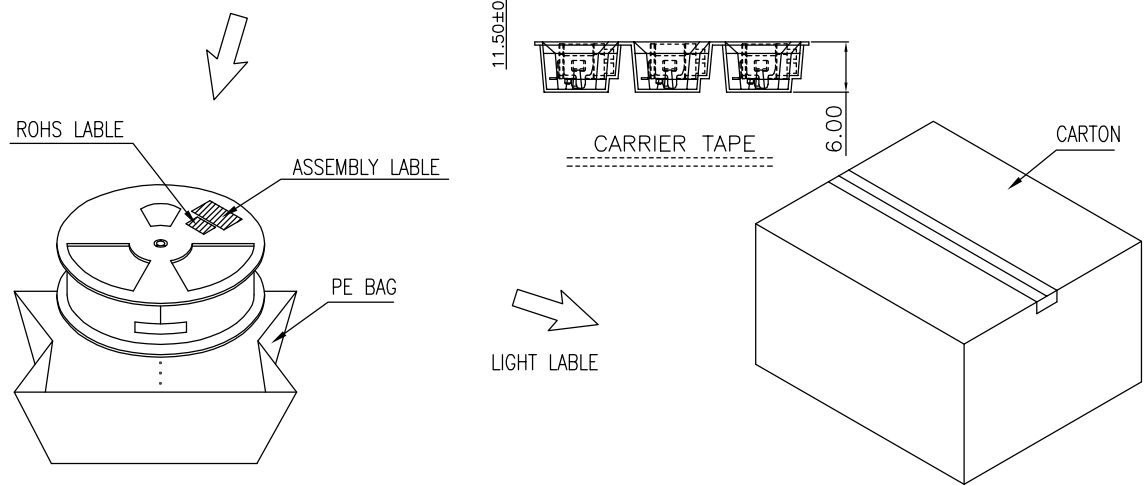

REV.	REVISION RECORD	DATE		GENERAL TOLERANCES		SCALE:	NAME	DATE	PART.NO: WLT2F9-062XX0136	DWG.NO: ENDE05	
A0	NEW RELEASE	21.01.13		LINEAR	ANGLES	1:1	Wang_jr	21.01.13			
			0.0±0.35	X°REF±6'	APPROVED	Han_Gao	21.01.13	TITLE: TYPE C 6P/F SMT L=7.15mm IPX7			
			UNIT:mm	X'±3'	DESIGNER	Zijun_Huang	21.01.13				
			SIZE: A4	0.000±0.10	X'X' ±2'	DRAWN			REV: A0	SHEET: 2/2	