

The product using material and processing must conform to the "WL-PZ-001" HSF technical standard control requirements

RoHS

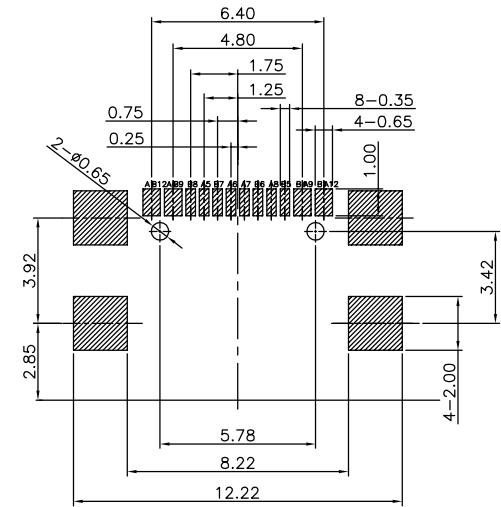
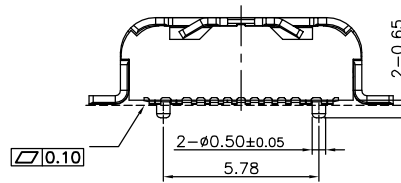
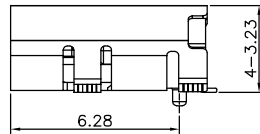
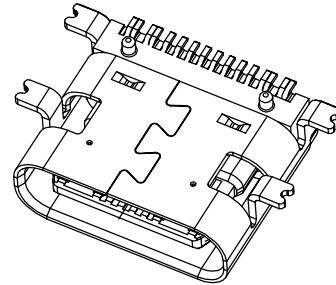
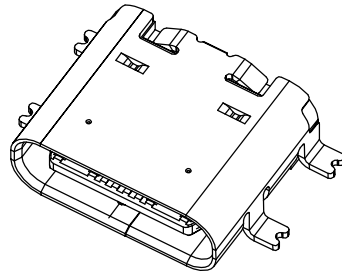
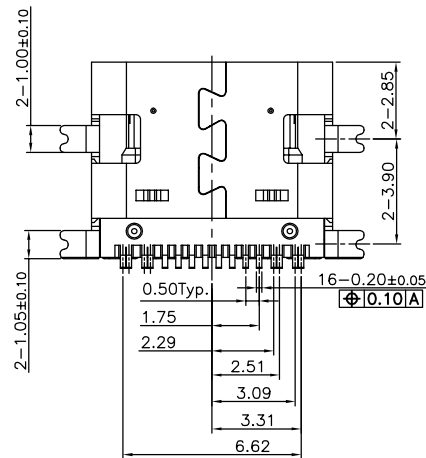
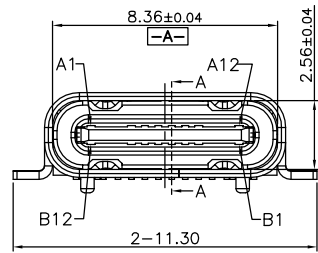
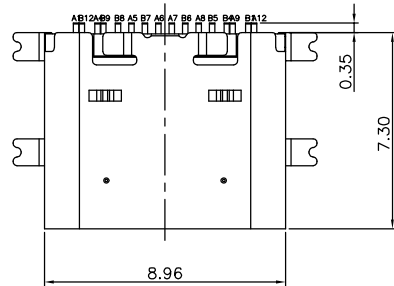

P.C.B LAYOUT VIEW

TOLERANCE ±0.05

NOTE:

- MATERIAL SPECIFICATION:
 - 1-HOUSING: LCP BLACK UL94V-0
 - 2-CONTACTS: COPPER ALLOY
 - 3-MID PLATE: STAINLESS STEEL
 - 4-SHELL: STAINLESS STEEL
- PLATING SPECIFICATION:
 - 2-1.CONTACTS: Ni 50u" MIN. UNDER PLATED OVER ALL. Au PLATED ON THE FUNCTIONAL AREA OF CONTACT.
 - 2-2.MID PLATE: CLEAR ONLY
 - 2-3.FRONT SHELL: Ni 30u" MIN. UNDER PLATED OVER ALL.
- MECHANICAL PERFORMANCE:
 - 3-1.INSERTION FORCE: 0.5~2.0kgf.
 - 3-2.REMOVAL FORCE: 0.8~2.0kgf.
 - 3-3.DURABILITY: 10000 CYCLES.
- ELECTRICAL PERFORMANCE:
 - 4-1. CURRENT RATING: 3.0A VOLTAGE RATING: 20V MAX
 - 4-2.CONTACT RESISTNACE: 30mΩ MAX
 - 4-3.INSULATION RESISTANCE: 100MΩ MIN
 - 4-4.WITHSTANDING VOLTAGE: 100V AC r.m.s.
- ENVIRONMENTAL PERFORMANCE:
 - OPERATING TEMPERATURE: -40°C~+85°C.

PIN ASSIGNMENT

Pin	Signal Name	Pin	Signal Name	Pin	Signal Name	Pin	Signal Name
A1	GND	B12	GND	A7	D-	B6	D+
A2	TX1+	B11	RX1-	A8	SBU1	B5	CC2
A3	TX1-	B10	RX1+	A9	VBUS	B4	VBUS
A4	VBUS	B9	VBUS	A10	RX2-	B3	TX2+
A5	CC1	B8	SBU2	A11	RX2+	B2	TX2+
A6	D+	B7	D-	A12	GND	B1	GND

PART.NO.: WLT2F9-16 2 X X 0 158

PLATING: 1-G/F 2-Au 3u" 5-Au 15u" 6-Au 30u"
 COLOUR: A-BLACK

REV.	REVISION RECORD	DATE	GENERAL TOLERANCES		SCALE:	NAME	DATE	PART.NO:	DWG.NO:	 WanLian Teconology Co., Ltd
A0	NEW RELEASE	21.01.13	LINEAR	ANGLES	1:1	Wang_jr	21.01.13	WLT2F9-162XX0158	ENDE05	
			0.00±0.25	X'±3'	APPROVED	Han_Gao	21.01.13	TITLE:		
			0.000±0.10	X*X' ±2'	DESIGNER	Zijun_Huang	21.01.13	TYPE C 16P/F SMT L=7.30mm		
			UNIT:mm		DRAWN					REV: A0 SHEET: 1/2

The product using material and processing must conform to the "WL-PZ-001"HSF technical standard control requirements

RoHS

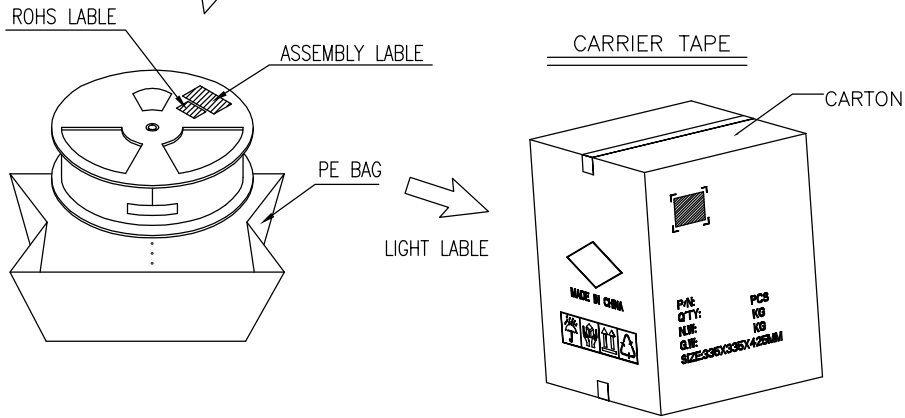
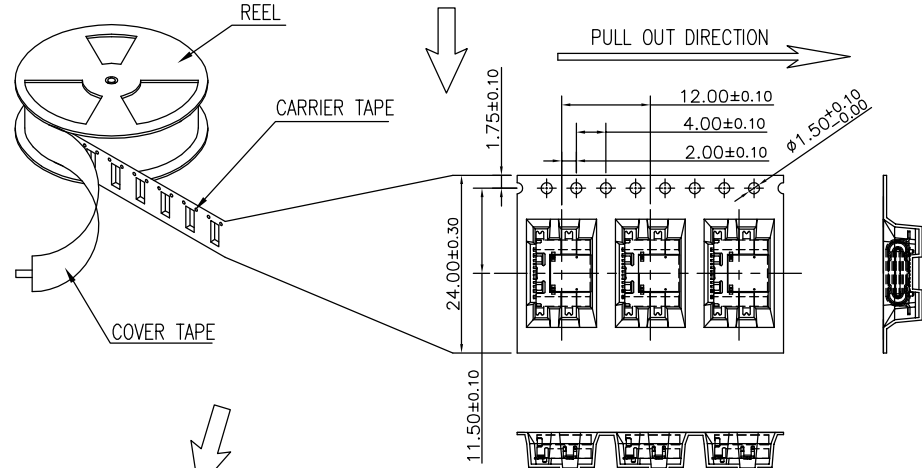
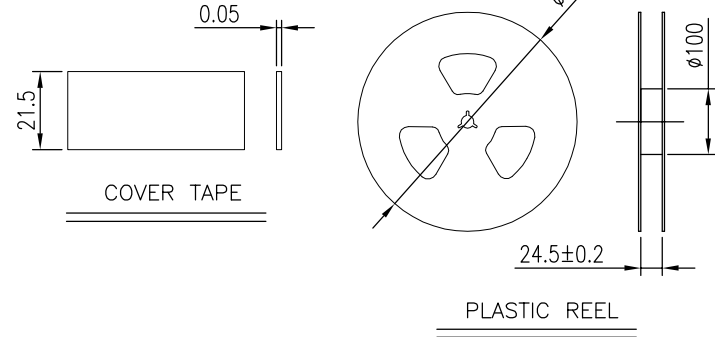
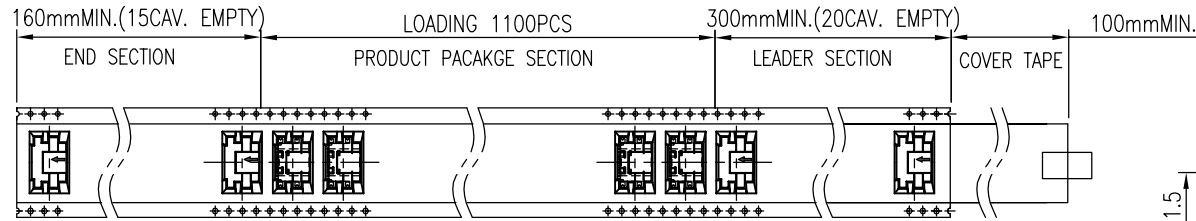

NOTES 2:

1. MATERIAL:

- 1.1 REEL AND AXLE: PS,BLUE
- 1.2 CARRIER TAPE: PET, LUCID
- 1.3 COVER TAPE: PS,TRANSPARENT
- 1.4 SHIPPING CARTON: CORRUGATED FIBER

2. DIMENSION:

- 2.1 REEL: W=24.5, $\phi A=330$
- 2.2 CARRIER TAPE: T=0.30 W=24.0
- 2.3 COVER TAPE: T=0.05 W=21.5
- 2.4 SHIPPING CARTON: L=335mm, W=335mm, H=425mm

3. QUANTITY :

- 3.1 PRIMAY PACKING: 1000PCS/REEL
- 3.2 SECONARY PACKING: 10 REELS/CARTON(10000PCS/CARTON)

4. PEELING RESISTANCE: 0.1~1.3N

- 4.1 PEELING SPEED: 300mm/minutes
- 4.2 PEELING ANGLE: 165° ~180°

REV.	REVISION RECORD	DATE		GENERAL TOLERANCES		SCALE: 1:1	NAME	DATE	PART.NO: WLT2F9-162XX0158	DWG.NO: ENDE05	
A0	NEW RELEASE	21.01.13		LINEAR	ANGLES	APPROVED	Wang_jr	21.01.13			
			UNIT:mm	0.00±0.25	X°REF±6'	DESIGNER	Han_Gao	21.01.13	TITLE: TYPE C 16P/F SMT L=7.30mm		
			SIZE: A4	0.000±0.10	X°X' ±2'	DRAWN	Zijun_Huang	21.01.13			