

The product using material and processing must conform to the "WL-PZ-001"HSF technical standard control requirements

RoHS

PIN ASSIGNMENT

Pin	Signal Name	Pin	Signal Name	Pin	Signal Name	Pin	Signal Name
A1	GND	B12	GND	A7	D-	B6	D+
A2	TX1+	B11	RX1-	A8	SBU1	B5	CC2
A3	TX1-	B10	RX1+	A9	VBUS	B4	VBUS
A4	VBUS	B9	VBUS	A10	RX2-	B3	TX2+
A5	CC1	B8	SBU2	A11	RX2+	B2	TX2+
A6	D+	B7	D-	A12	GND	B1	GND

NOTE:

- MATERIAL SPECIFICATION:
 - 1.SHELL: STAINLESS STEEL
 - 2.HOUSING: LCP BLACK UL94V-0
 - 1-3.CONTACT: COPPER ALLOY
 - 1-4.MID PLATE: STAINLESS STEEL
 - 1-5.CAP: LCP BLACK UL94V-0
- PLATING SPECIFICATION:
 - 2-1.SHELL: Ni 50~100u" UNDER PLATED OVER ALL.
 - 2-2.CONTACT: Ni 30~80u" MIN PLATED ON CONTACT AREA
Au 1u" MIN PLATED ON CONTACT AREA
Ni 30~80u" MIN PLATED ON SOLDER AREA
MATTE TIN 50U MIN PLATED ON CONTACT AREA
- MECHANICAL PERFORMANCE:
 - 3-1.INSERTION FORCE: 0.5~2.0kgf
 - 3-2.REMOVAL FORCE: 0.8~2.0kgf
 - 3-3.DURABILITY: 10000 CYCLES.
- ELECTRICAL PERFORMANCE:
 - 4-1. CURRENT RATING:5.0A
VOLTAGE RATING:20V MAX
 - 4-2.CONTACT RESISTNACE: 30mΩ MAX
 - 4-3.INSULATION RESISTANCE: 100MΩ MIN
 - 4-4.WITHSTANDING VOLTAGE: 100V AC r.m.s.
- ENVIRONMENTAL PERFORMANCE:
 - OPERATING TEMPERATURE: -40°C~+85°C.
- P/N ORDER:

WLT4F0-24 2 X X 0 137

PLATING: 1-G/F 2-Au 3u" 5-Au 15u" 6-Au 30u"
COLOUR: A-BLACK D-ORANGE

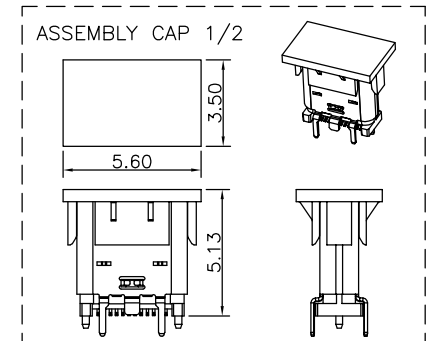
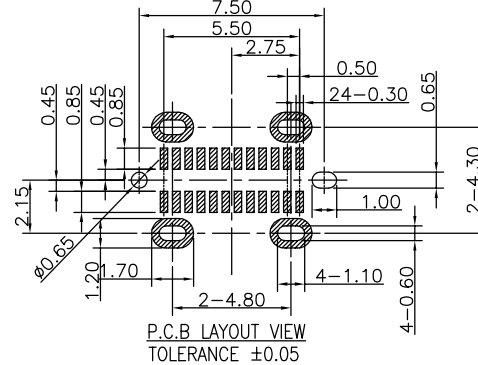
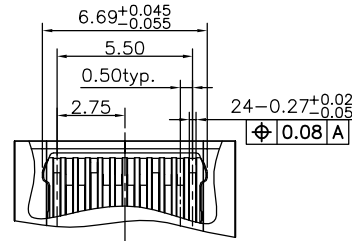
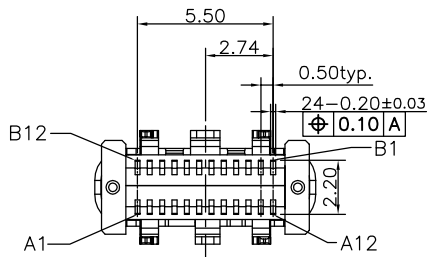
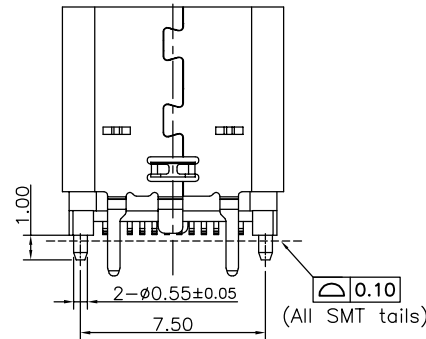
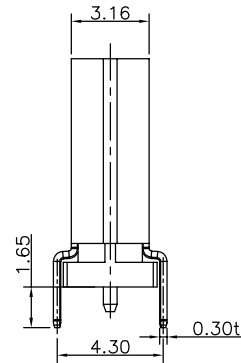
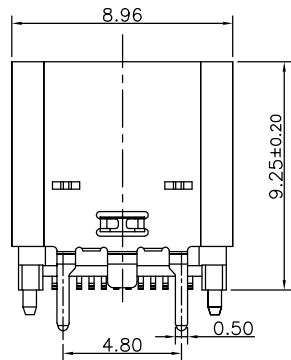
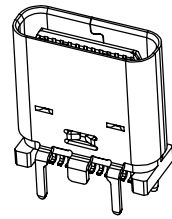
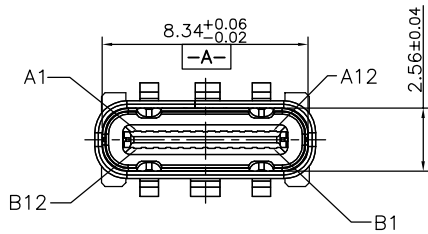

REV.	REVISION RECORD	DATE	UNIT:mm	GENERAL TOLERANCES		SCALE:	NAME	DATE	PART.NO:	DWG.NO:	 WanLian Teconology Co., Ltd
A0	NEW RELEASE	21.01.13		LINEAR	ANGLES	1:1	Wang_jr	21.01.13	WLT4F0-242XX0137	ENDE05	
			0.00±0.25	X'±3'	DESIGNER	Han_Gao	21.01.13		TITLE:		REV: A0
			0.000±0.10	X'X' ±2'	DRAWN	Zijun_Huang	21.01.13		TYPE C 24P/F SMT On the vertical board 9.30H		SHEET: 1/2

The product using material and processing must conform to the "WL-PZ-001"HSF technical standard control requirements



160mmMIN.(15CAV. EMPTY) LOADING 550PCS 300mmMIN.(20CAV. EMPTY) 100mmMIN. COVER TAPE

END SECTION PRODUCT PACAKGE SECTION LEADER SECTION

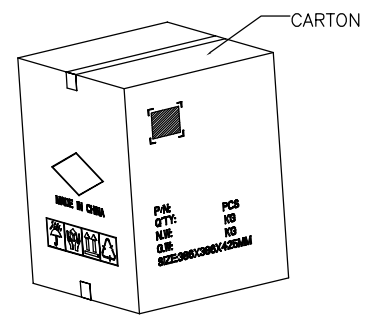
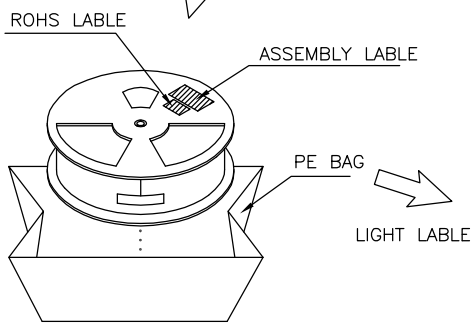
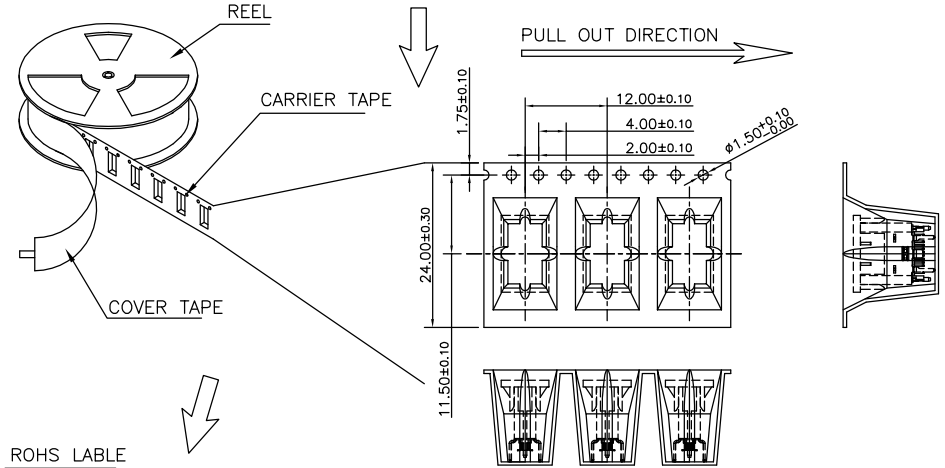
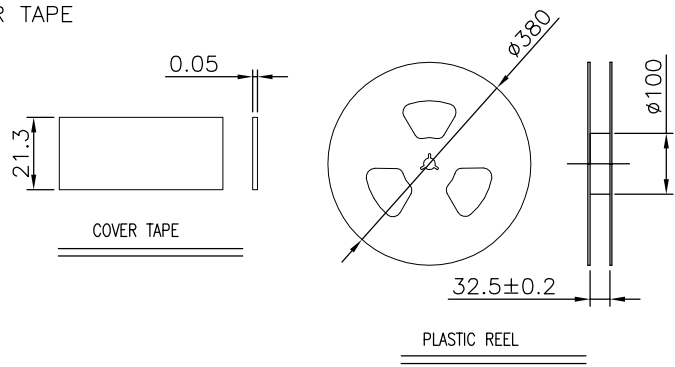
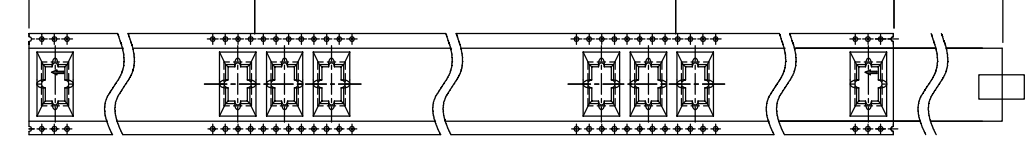

- NOTES 2:
- MATERIAL:
 - 1.1 REEL AND AXLE: PS,BLUE
 - 1.2 CARRIER TAPE: PET, LUCID
 - 1.3 COVER TAPE: PS,TRANSPARENT
 - 1.4 SHIPPING CARTON: CORRUGATED FIBER
 - DIMENSION:
 - 2.1 REEL: W=24.5, φA=380
 - 2.2 CARRIER TAPE: T=0.50 W=24.0
 - 2.3 COVER TAPE: T=0.05 W=21.3
 - 2.4 SHIPPING CARTON: L=386mm, W=386mm, H=425mm
 - QUANTITY :
 - 3.1 PRIMAY PACKING: 550PCS/REEL
 - 3.2 SECONARY PACKING: 12 REELS/CARTON(6600PCS/CARTON)
 - PEELING RESISTANCE: 0.1~1.3N
 - 4.1 PEELING SPEED: 300mm/minutes
 - 4.2 PEELING ANGLE: 165° ~180°

REV.	REVISION RECORD	DATE		GENERAL TOLERANCES		SCALE: 1:1	NAME	DATE	PART.NO: WLT4F0-242XX0137	DWG.NO: ENDE05	 WanLian Teconology Co., Ltd	
A0	NEW RELEASE	21.01.13		LINEAR	ANGLES	APPROVED	Wang_jr	21.01.13				
			UNIT:mm	0.00±0.25	X'±3'	DESIGNER	Han_Gao	21.01.13	TITLE: TYPE C 24P/F SMT On the vertical board 9.30H		REV: A0	SHEET: 2/2
			SIZE: A4	0.000±0.10	X'X' ±2'	DRAWN	Zijun_Huang	21.01.13				