

The product using material and processing must conform to the "WI-PZ-001"HSF technical standard control requirements

(RoHS)

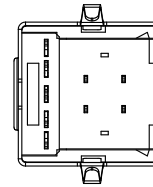
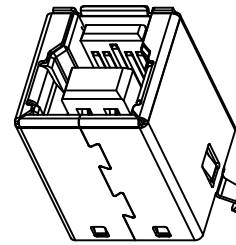
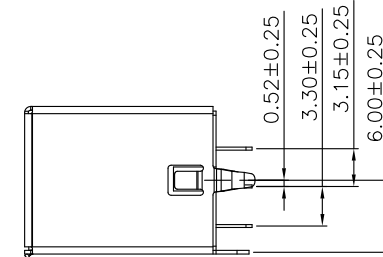
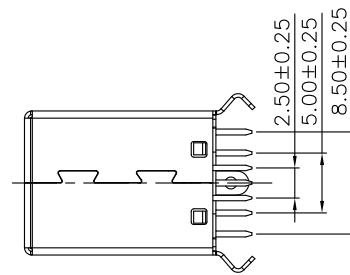
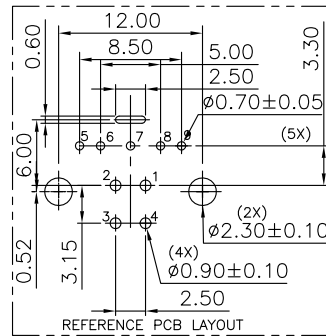

NOTE:

1.MATERIAL SPECIFICATION:

- 1-1.HOUSING:  
LCP+30%GF 94V-0 COLOUR:BULE
- 1-2.CONTACT:COPPER ALLOY (T=0.25mm)
- 1-3.SHELL:BRASS

2.PLATING SPECIFICATION:

- 2-1.CONTACTS:  
Ni 50u" MIN. UNDER PLATED OVER ALL.  
Sn 80u"MIN ON SOLDER AREA  
Au PLATED ON THE CONTACTS AREA.
- 2-2. SHELL:  
Ni 30u" MIN. UNDER PLATED OVER ALL.

3.MECHANICAL PERFORMANCE:

- 3-1.INSERTION FORCE: 3.57kgf MAX
- 3-2.REMOVAL FORCE: 1.02kgf MIN
- 3-3.DURABILITY: 3000 CYCLES.

4.ELECTRICAL PERFORMANCE:

- 4-1.CURRENT RATING:1.5A
- 4-2.VOLTAGE RATING:30V MAX
- 4-3.CONTACT RESISTANCE: 30m Ohm MAX.
- 4-4.INSULATION RESISTANCE: 100MΩ MIN
- 4-5.DIELECTRIC WITHSTANDING VOLTAGE:100V AC

5.ENVIRONMENTAL PERFORMANCE:

OPERATING TEMPERATURE: -40°C~+85°C.

6.PACKAGE SPEC:TRAY

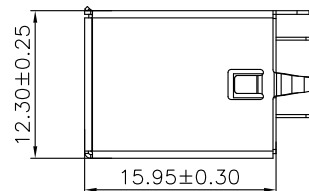
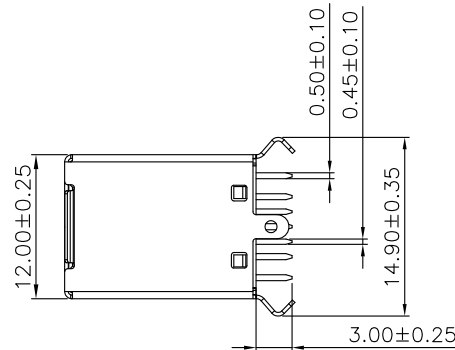
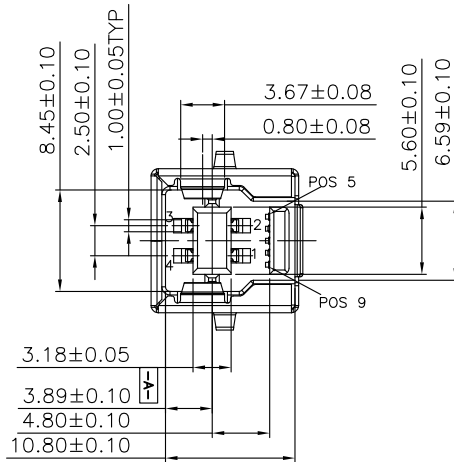

WLU3F0-09 1 X X X 169

PLATED:  
1-G/F  
2-Au 3u"  
5-Au 15u"  
6-Au 30u"

HOUSING:  
1-PBT  
2-LCP  
3-PA9T

HOUSING COLOUR:  
A-BLACK  
G-BLUE

Pin Number	Signal Name	Pin Number	Signal Name
1	VBUS	5	StdB_SSTX-
2	D-	6	StdB_SSTX+
3	D+	7	GND_DRAIN
4	GND	8	StdB_SSRX-
Shell	Shield	9	StdB_SSRX+

REV.	REVISION RECORD	DATE	GENERAL TOLERANCES		SCALE:	NAME	DATE	PART.NO:	DWG.NO:	 WanLian Teconology Co., Ltd	
A0	NEW RELEASE	21.01.13	LINEAR	ANGLES	1:1	Wang_jr	21.01.13	WLU3F0-091XXX169	ENDE05		
			0.0±0.35	X°REF±6°	APPROVED	Han_Gao	21.01.13	TITLE:			
			0.00±0.25	X°±3°	DESIGNER	Zijun_Huang	21.01.13	USB3.0 BF DIP L=15.95mm			
			UNIT:mm	X°X' ±2°	DRAWN					REV: A0	SHEET: 1/1
			SIZE: A4	0.000±0.10							