

The product using material and processing must conform to the "WL-PZ-001" HSF technical standard control requirements

RoHS

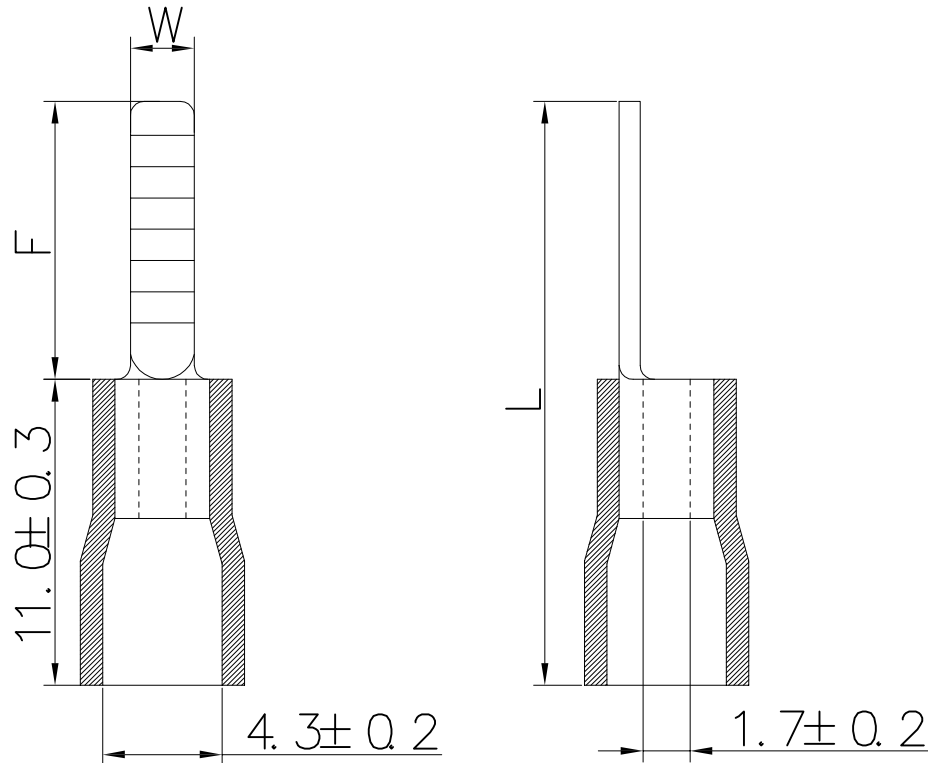

备注:

1. 接压线径: 0.5-1.5mm² (22-16AWG)
2. 端子材质: 紫铜, 厚度: 0.75±0.03
3. 绝缘材质: 尼龙, 绝缘护套温度: 105° C, 绝缘护套颜色: 红色
4. 表面处理: 镀锡, 镀层厚度: 2.5 μm-5 μm, 镀层温度: 120° /2小时
5. 接线类型: 绞合线或实心
6. 最大电流: 19A

Item NO.料号	mm/inch 主要尺寸		
	W	L	F
WLLA14-100AA03CB86	2.3±0.2	21.0±0.3	10.0±0.3
WLLA14-140AA03CB86	2.3±0.2	25.0±0.3	14.0±0.3
WLLA14-180AA03CB86	2.2±0.2	29.0±0.3	18.0±0.3

REV.	REVISION RECORD	DATE		GENERAL TOLERANCES		SCALE: 1:1	NAME	DATE	PART.NO:	DWG.NO:	
A0	NEW RELEASE	22.05.09		LINEAR 0.00±0.25 UNIT:mm SIZE: A4	ANGLES X°REF±6° X°±3° X°X'±2°	APPROVED	Wang_jr	22.05.09	WLLA14-XXXAA03CB86	ENDE05	
					DESIGNER	Han_Gao	22.05.09	TITLE: 尼龙绝缘护套片形单粒端子 DBVN1.25系列			
					DRAWN	LanXuan_Hou	22.05.09				