

The product using material and processing must conform to the "WL-PZ-001"HSF technical standard control requirements

RoHS

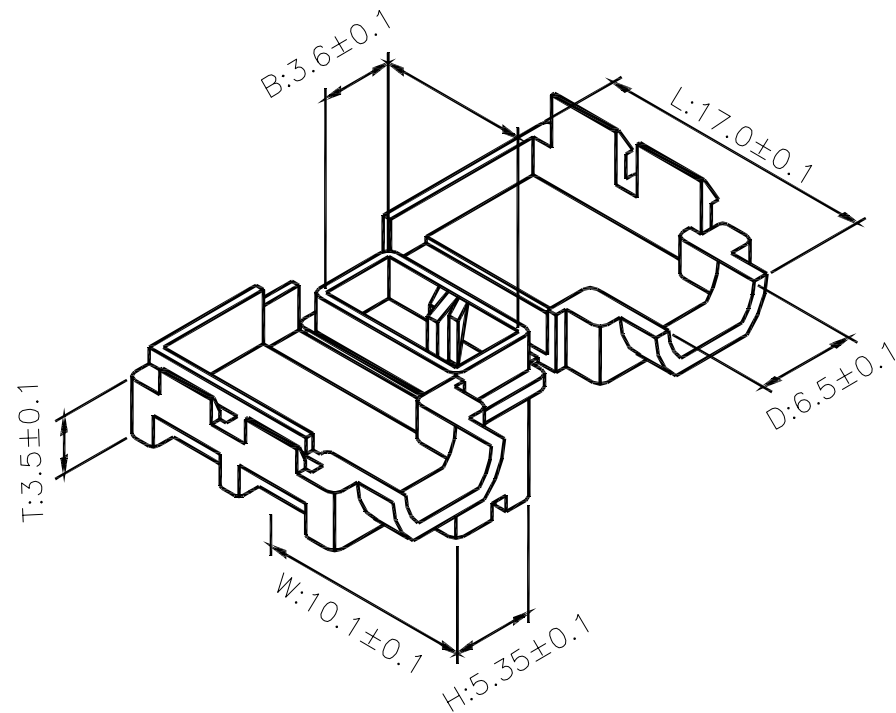

备注：  
 绝缘材质：尼龙PA66  
 绝缘护套温度：75° C  
 绝缘护套颜色：白色  
 绝缘电阻：1000 MΩ  
 额定电压：250V  
 额定电流：10A  
 耐电压：1000V.AC

REV.	REVISION RECORD	DATE		GENERAL TOLERANCES		SCALE:	NAME	DATE	PART.NO:	DWG.NO:	
AO	NEW RELEASE	22.05.09		LINEAR	ANGLES	1:1	Wang_jr	22.05.09	WLLFQN-009KB53	ENDE05	
			UNIT:mm	0.00±0.25	X'±3'	DESIGNER	Han_Gao	22.05.09	TITLE: 250系列尼龙绝缘旗形硬护套 尼龙PA66 白色		REV: A0    SHEET: 1/1
			SIZE: A4	0.000±0.10	X'X' ±2'	DRAWN	LanXuan_Hou	22.05.09			