

The product using material and processing must conform to the "WL-PZ-001"HSF technical standard control requirements

RoHS

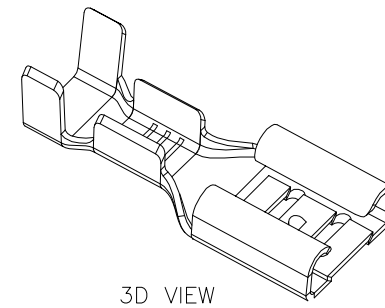
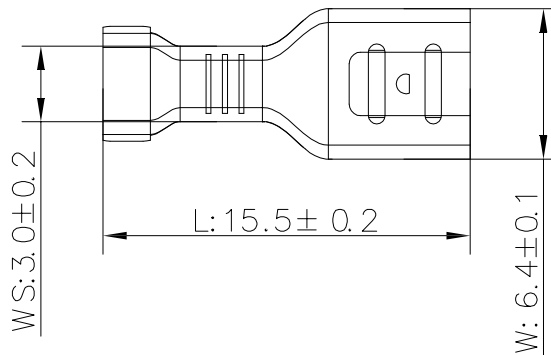
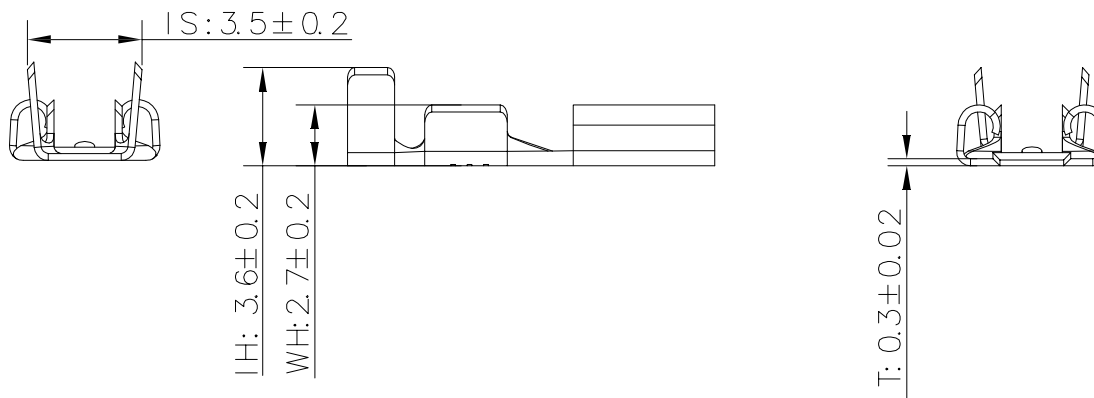
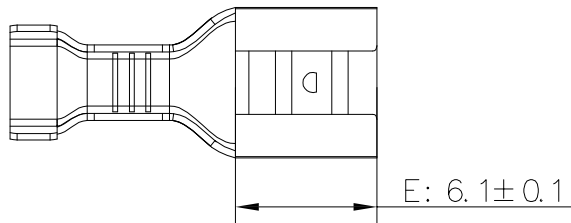

- 备注:
1. 接线: 22-24AWG
  2. 端子材质: 黄铜, 表面处理: 镀锡
  3. 对插端子: 205公端/T=0.5
  4. 拔力范围:  $\geq 4.0\text{kg}$ , 插力范围:  $\leq 3.5\text{kg}$

REV.	REVISION RECORD	DATE		GENERAL TOLERANCES		SCALE: 1:1	NAME	DATE	PART.NO:	DWG.NO:	 WanLian Teconology Co., Ltd
AO	NEW RELEASE	22.05.09		LINEAR	ANGLES	APPROVED	Wang_jr	22.05.09	WLLN2F0-A02010001	ENDE05	
			UNIT:mm	0.00±0.25	X'±3'	DESIGNER	Han_Gao	22.05.09	TITLE:		REV: A0 SHEET: 1/1
			SIZE: A4	0.000±0.10	X'X' ±2'	DRAWN	LanXuan_Hou	22.05.09	无绝缘205系列直型母插片连续端子 公片厚度0.5mm		