

The product using material and processing must conform to the "WL-PZ-001"HSF technical standard control requirements

RoHS

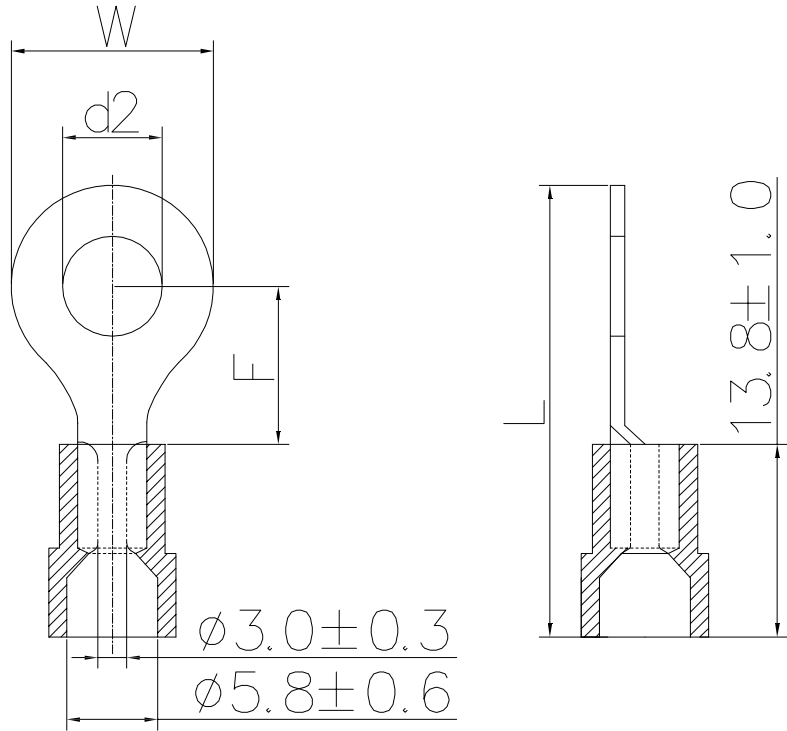

备注:

1. 接压线径: 2.5-4.0mm<sup>2</sup> (14-12AWG)
2. 端子材质: 紫铜, 厚度: 1.0±0.03
3. 绝缘材质: PVC, 绝缘护套温度: 常温, 绝缘护套颜色: 黑色
4. 表面处理: 镀锡, 镀层厚度: 2.5 μm-5 μm, 镀层温度: 120° /2小时
5. 接线类型: 绞合线
6. 最大电流: 37A

ItemNO. 料号	螺栓规格 Stud Size	mm/inch 主要尺寸			
		d2	W	F	L
WLLR13-043AC03AB43	# 8	4.3±0.2	8.0±0.15	7.7±1.0	25.3±1.0
WLLR13-053AC03AB44	# 10	5.3±0.2	8.0±0.15	7.7±1.0	25.3±1.0
WLLR13-053AC03AB45	# 10	5.3±0.2	12.0±0.15	9.3±1.0	27.9±1.0
WLLR13-064AC03AB46	1/4	6.4±0.3	12.0±0.15	9.3±1.0	29.0±1.0
WLLR13-084AC03AB47	5/16	8.4±0.3	15.0±0.15	14.0±1.0	35.0±1.0
WLLR13-105AC03AB48	3/8	10.5±0.3	15.0±0.15	14.0±1.0	34.6±1.0

REV.	REVISION RECORD	DATE		GENERAL TOLERANCES		SCALE: 1:1	NAME	DATE	PART.NO:	DWG.NO:	
AO	NEW RELEASE	22.04.13		LINEAR 0.0±0.35 UNIT:mm SIZE: A4	ANGLES X'REF±6° X'±3° X'X' ±2°	APPROVED	Wang_jr	22.04.13	WLLR13-XXXAC03AXXX	ENDE05	
					DESIGNER	Han_Gao	22.04.13	TITLE:	半绝缘PVC绝缘护套0形端子 压线12-14AWG		
					DRAWN	LanXuan_Hou	22.04.13				