

The product using material and processing must conform to the "WI-PZ-001"HSF technical standard control requirements

RoHS

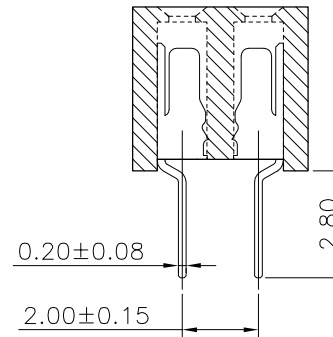
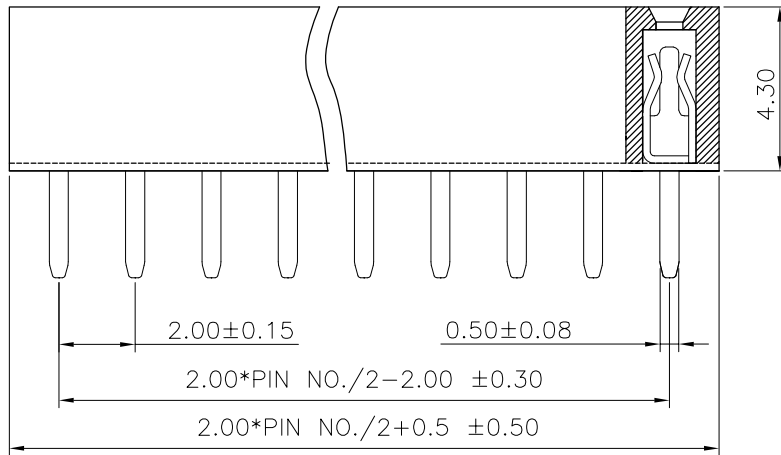
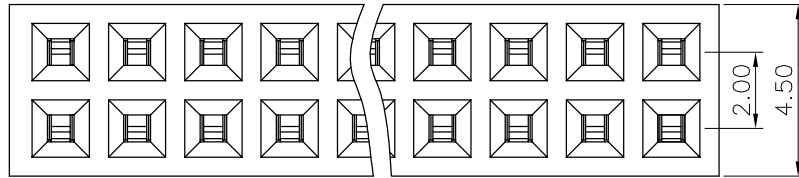

- NOTE:
- MATERIAL SPECIFICATION:
    - 1-1.HOUSING: UL94V-0
    - 1-2.CONTACTS: BRASS
  - PLATING SPECIFICATION:
    - 2-1.CONTACTS: GOLD FLASH OVER NICKEL
  - ELECTRICAL PERFORMANCE:
    - 3-1.CURRENT RATING: 2A
    - 3-2.CONTACT RESISTANCE: 30 mΩ MAX
    - 3-3.INSULATION RESISTANCE: 1000MΩ Min
    - 3-4.DIELECTRIC WITHSTANDING : 300V
  - ENVIRONMENTAL PERFORMANCE:
    - 4-1.OPERATING TEMPERATURE: -40°C~+105°C.
  - PACKAGE SPEC: TRAY
  - P/N:

FH2005 43 F 0-2 XX 1 X X X 01

SERIES NO: \_\_\_\_\_ HOUSING: 1-PA6T

HEIGHT: \_\_\_\_\_ COLOR: A-BLACK

43: 4.3mm

MALE FEMALE: \_\_\_\_\_ PLATING: A-ALL AU G/F

F-FEMALE

ANGLE: \_\_\_\_\_

0-180°

ROW NO: \_\_\_\_\_

2-DOUBLE ROW

PIN Q'PY: \_\_\_\_\_ TERMIPOINT: 1-DIP

02~80

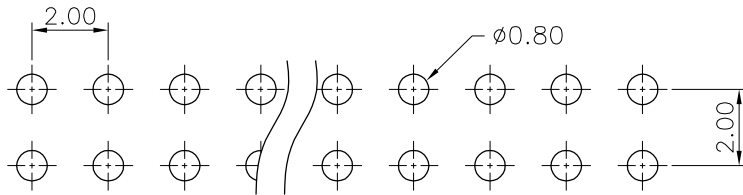

RECOMMENDED P.C.B LAYOUT  
P.C.B TOLERANCE:±0.05

REV.	REVISION RECORD	DATE		GENERAL TOLERANCES		SCALE: 1:1	NAME	DATE	PART.NO: FH200543F0-2XX1XXX01	DWG.NO: ENDE05	 WanLian Technology Co., Ltd	
AO	NEW RELEASE	21.10.15		LINEAR	ANGLES	APPROVED	Wang_jr	21.10.15				
			UNIT:mm	0.00±0.25	X'±3'	DESIGNER	Gao_Han	21.10.15	TITLE: 2.0双排母 180度 PC2.8 H4.3W4.5	REV: A0		SHEET: 1/1
			SIZE: A4	0.000±0.10	X'X' ±2'	DRAWN	Gao_Han	21.10.15				