

The product using material and processing must conform to the "WI-PZ-001" HSF technical standard control requirements

RoHS

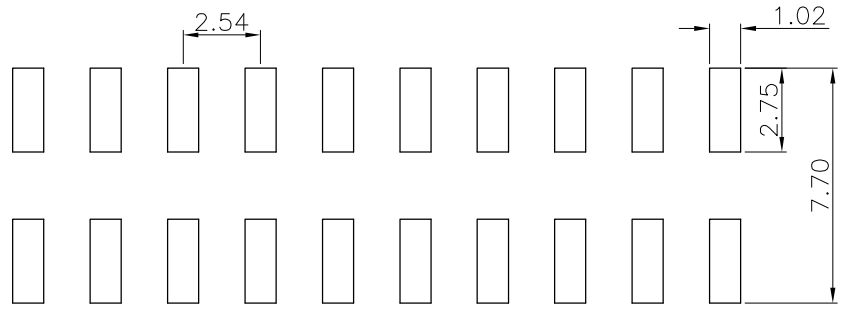
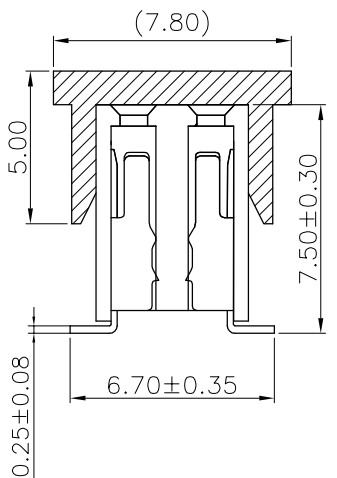
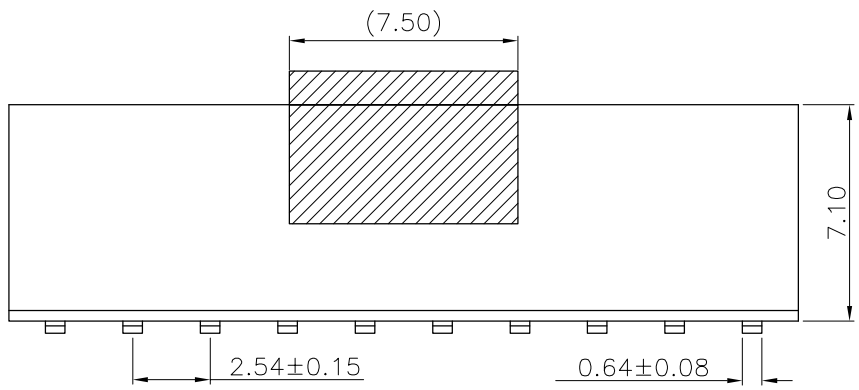
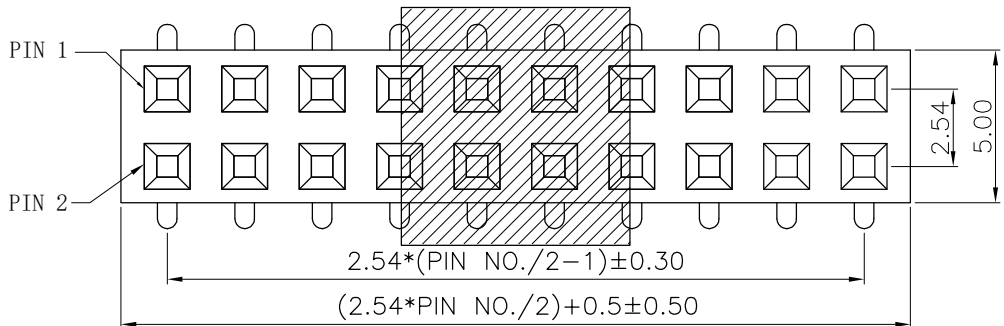

RECOMMENDED P. C. B LAYOUT
P. C. B TOLERANCE: ±0.05

- NOTE:
- MATERIAL SPECIFICATION:
 - HOUSING: UL94V-0
 - CONTACTS: BRASS
 - PLATING SPECIFICATION:
 - CONTACTS: GOLD FLASH/TIN OVER NICKEL
 - ELECTRICAL PERFORMANCE:
 - CURRENT RATING: 3A
 - CONTACT RESISTANCE: 30 mΩ MAX
 - INSULATION RESISTANCE: 1000MΩ Min
 - DIELECTRIC WITHSTANDING : 500V
 - ENVIRONMENTAL PERFORMANCE:
 - OPERATING TEMPERATURE: -40°C~+105°C.
 - PACKAGE SPEC: REEL
 - P/N:

FH2541 71 F 0-2 XX 2 X X X 02

SERIES NO: _____

HEIGHT: _____
71: 7.1mm

MALE FEMALE: _____
F-FEMALE

ANGLE: _____
0-180°

ROW NO: _____
2-DOUBLE ROW

PIN Q' PY: _____
02~80

HOUSING:
1-PA9T
7-PA6T

COLOR:
A-BLACK

PLATING:
A-ALL AU G/F

TERMIPOINT:
2-SMT

REV.	REVISION RECORD	DATE	UNIT:mm	GENERAL TOLERANCES		SCALE: 1:1	NAME	DATE	PART.NO:	DWG.NO:	 WanLian Technology Co., Ltd
A0	NEW RELEASE	21.10.15		LINEAR	ANGLES	APPROVED	Wang_jr	23.10.10	FH254171F0-2XX2XXX02	ENDE05	
A1	依实物更新包装数量	23.10.10	SIZE: A4	0.00±0.25	X'±3'	DESIGNER	Gao_Han	23.10.10	TITLE: Pitch 2.54mm 180° 双排H6.7 SMT U型排母	REV: A1	SHEET: 1/2
				0.00±0.35	X*REF±6'	DRAWN	Gao_Han	23.10.10			

The product using material and processing must conform to the "WI-PZ-001" HSF technical standard control requirements

RoHS

NOTE:

- 1、成品组装完并OQ检查完后、将其装入承载带内、同时用封装胶带冷封
- 2、检查REEL板状卷带是否松动，如有松动需要重新贴紧
- 3、全检OK后、将REEL装盘入PE袋并放入一包干燥剂
- 4、每个REEL上必须贴上料号以及数量
- 5、产品放入REEL时前后各空16PCS不放产品
- 6、每盘装产品600PCS，每箱装6盘，每一外箱装产品600*6=3600PCS
- 7、保护带:材质为PET;透明色;
- 8、上带:材质为PET;透明色;冷风自粘带
- 9、Reel卷盘:PS材质;蓝色

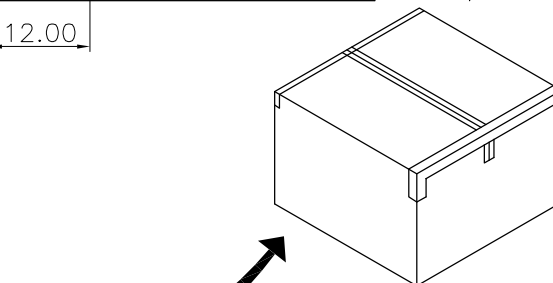
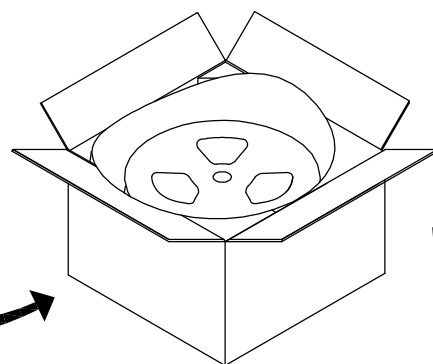
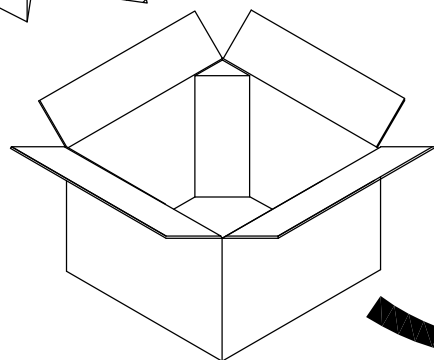
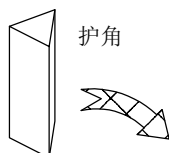
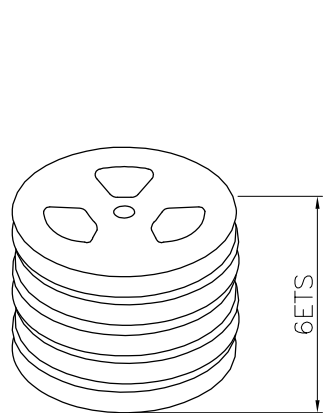
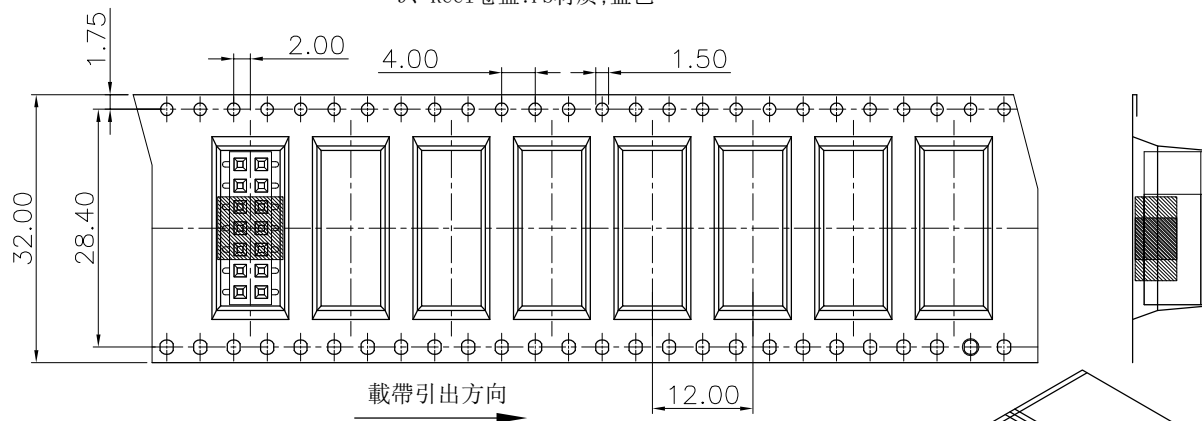
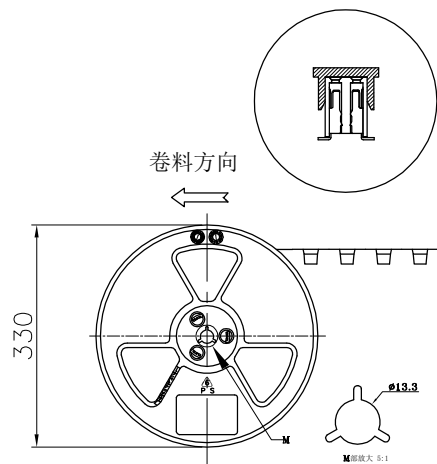

Carton B surface

纸箱规格: K-R 338*338*260mm

REV.	REVISION RECORD	DATE		GENERAL TOLERANCES		SCALE: 1:1	NAME	DATE	PART.NO: FH254171F0-2XX2XXX02	DWG.NO: ENDE05	 WanLian Technology Co., Ltd
A0	NEW RELEASE	21.10.15		LINEAR	ANGLES	APPROVED	Wang_jr	23.10.10			
A1	依实物更新包装数量	23.10.10	UNIT:mm	0.00±0.25	X'±3'	DESIGNER	Gao_Han	23.10.10	TITLE: Pitch 2.54mm 180° 双排H6.7 SMT U型排母	REV: A1	SHEET: 2/2
			SIZE: A4	0.000±0.10	X'X' ±2'	DRAWN	Gao_Han	23.10.10			