

The product using material and processing must conform to the "WL-PZ-001" HSF technical standard control requirements

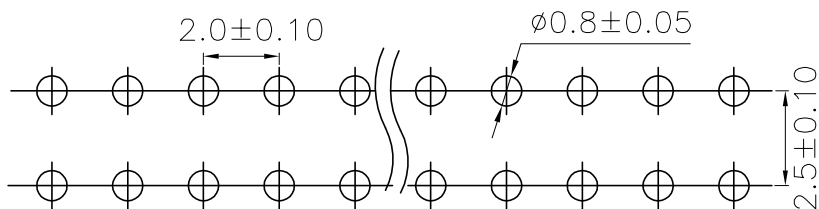

NOTE:
 1.MATERIAL SPECIFICATION:
 1-1.HOUSING: UL94V-0
 1-2.CONTACTS: BRASS
 2.PLATING SPECIFICATION:
 2-1.CONTACTS:
 TIN/GOLD FLASH PLATED OVER ALL.
 3.MECHANICAL PERFORMANCE:
 3-1.RETENTIVITY FORCE: 0.4KGF/pin min
 3-2.DURABILITY: 100 CYCLES.
 4.ELECTRICAL PERFORMANCE:
 4-1.CURRENT RATING: 2A AC/DC
 RATED VOLTAGE : 500V AC/DC
 4-2.CONTACT RESISTANCE: 20 mΩ MAX
 4-3.INSULATION RESISTANCE: 1000MΩ Min
 4-4.DIELECTRIC WITHSTANDING : 500V
 5.ENVIRONMENTAL PERFORMANCE:
 5-1.OPERATING TEMPERATURE: -40°C~+105°C.
 6.PACKAGE SPEC: TRAY
 7.P/N:

BH20750 F 0-2 XX 1 X X X
 SERIES NO: _____ HOUSING:
 1-PBT 2-PA6T
 3-PA9T 4-LCP
 MALE FEMALE: _____ COLOR:
 F-FEMALE A-BLACK
 K-WHITE
 S-NATURE
 ANGLE: _____ PLATING:
 9-90~ A-ALL AU G/F
 0-180~ C-BRIGHT TIN
 D-MATTE Tin
 ROW NO: _____ PIN Q'PY: _____ TERMIPOINT:
 2-DOUBLE ROW 06~64 1-DIP

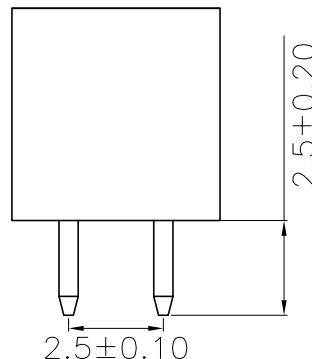
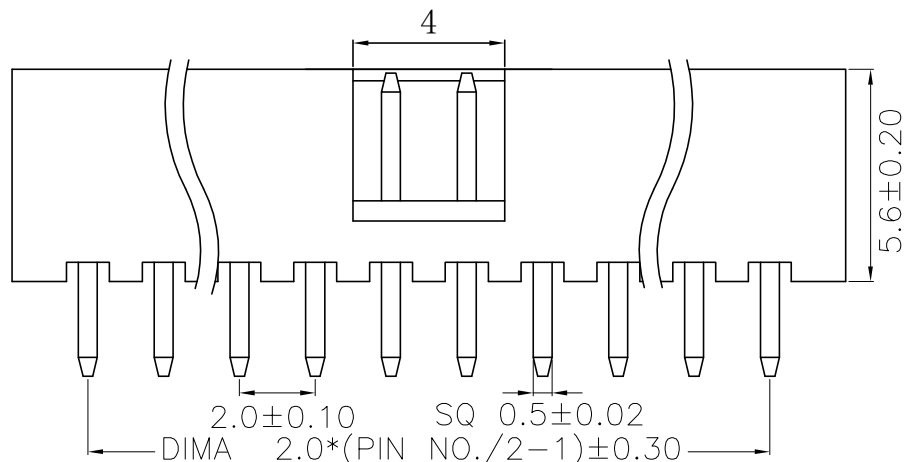
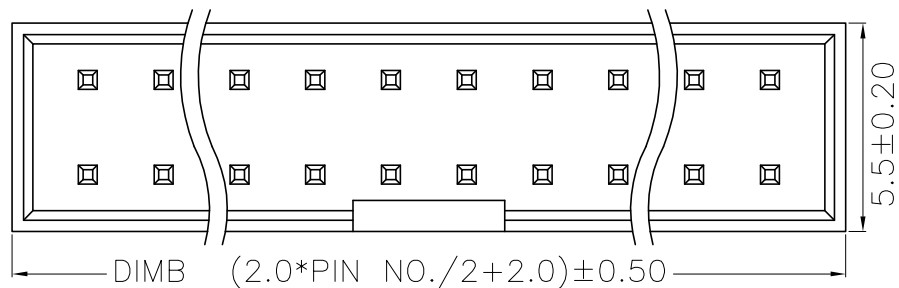

Recommended P. C. B. Hole Layout

PIN NO.	DIMENSION		PIN NO.	DIMENSION		PIN NO.	DIMENSION	
	DIMA	DIMB		DIMA	DIMB		DIMA	DIMB
2*3	4.0	13.5	2*10	18.0	27.5	2*18	34.0	43.5
2*4	6.0	15.5	2*11	20.0	29.5	2*20	38.0	47.5
2*5	8.0	17.5	2*12	22.0	31.5	2*22	42.0	51.5
2*6	10.0	19.5	2*13	24.0	33.5	2*25	48.0	57.5
2*7	12.0	21.5	2*14	26.0	35.5	2*30	58.0	67.5
2*8	14.0	23.5	2*15	28.0	37.5	2*32	62.0	71.5
2*9	16.0	25.5	2*17	32.0	41.5			

REV.	REVISION RECORD	DATE	UNIT:mm	GENERAL TOLERANCES		SCALE:	NAME	DATE	PART.NO:	DWG.NO:	
AO	NEW RELEASE	22.05.09		SIZE: A4	LINEAR	ANGLES	1:1	APPROVED	DESIGNER	TITLE:	
				0.00±0.25	X'±3'		DESIGNER	Han_Gao	PITCH 2.00mm筒牛 塑高5.6 PC2.5		REV: A0
				0.00±0.10	X'X' ±2'		DRAWN	LanXuan_Hou			SHEET: 1/2

The product using material and processing must conform to the "WL-PZ-001"HSF technical standard control requirements

RoHS

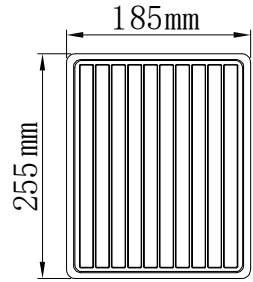

NO. 1

产品装入真空盒内

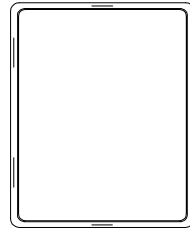

NO. 2

盖上盒盖并四边订上订书钉

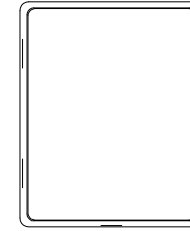

NO. 3

贴标签于真空盒左上角

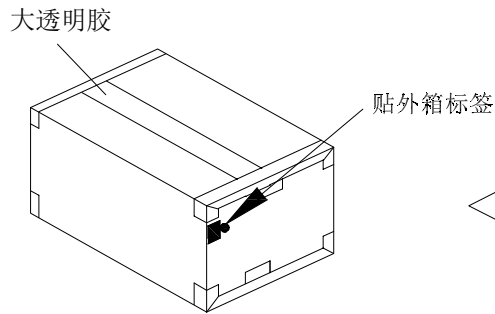

NO. 5

封箱及贴标签于纸箱侧面的左上角

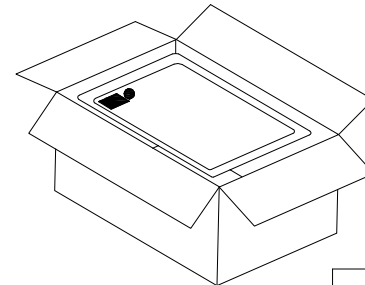

NO. 4

说明:

- 1、产品如图所示型态放入真空盒；
- 2、注意各标签样式，位置及方向的一致性；
- 3、打外箱包装袋时需注意，打为十字型；

PIN位	产品总长	包装数量(直) PCS/盘	包装数量(弯) PCS/盘	PIN位	产品总长	包装数量(直) PCS/盘	包装数量(弯) PCS/盘
2*03P	13.5	320.00	300.00	2*13P	33.5	120.00	120.00
2*04P	15.5	280.00	260.00	2*14P	35.5	120.00	120.00
2*05P	17.5	220.00	220.00	2*15P	37.5	120.00	120.00
2*06P	19.5	220.00	200.00	2*16P	41.5	100.00	100.00
2*07P	21.5	200.00	180.00	2*17P	43.5	100.00	80.00
2*08P	23.5	180.00	180.00	2*18P	47.5	80.00	80.00
2*09P	25.5	160.00	160.00	2*20P	51.5	80.00	80.00
2*10P	27.5	160.00	160.00	2*22P	51.5	60.00	60.00
2*11P	29.5	140.00	140.00	2*30P	67.5	60.00	60.00
2*12P	31.5	140.00	120.00	2*32P	71.5	60.00	40.00

REV.	REVISION RECORD	DATE		GENERAL TOLERANCES		SCALE: 1:1	NAME	DATE	PART.NO:	DWG.NO:	 WanLian Technology Co., Ltd	
AO	NEW RELEASE	22.05.09		LINEAR	ANGLES	APPROVED	Wang_jr	22.05.09	BH20750F0-2XX1XXX	ENDE05		
			UNIT:mm	0.00±0.25	X'±3'	DESIGNER	Han_Gao	22.05.09	TITLE:		REV: A0	SHEET: 2/2
			SIZE: A4	0.000±0.10	X'X' ±2'	DRAWN	LanXuan_Hou	22.05.09	包装规范			