

1 2 3 4 5 6 7 8

A
B
C
D
E
F

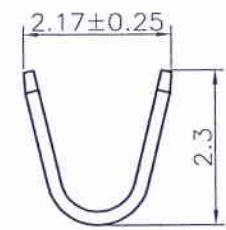

SECTION A-A

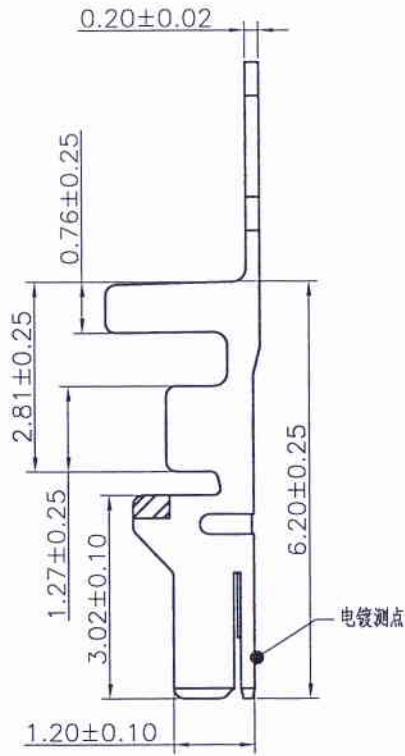
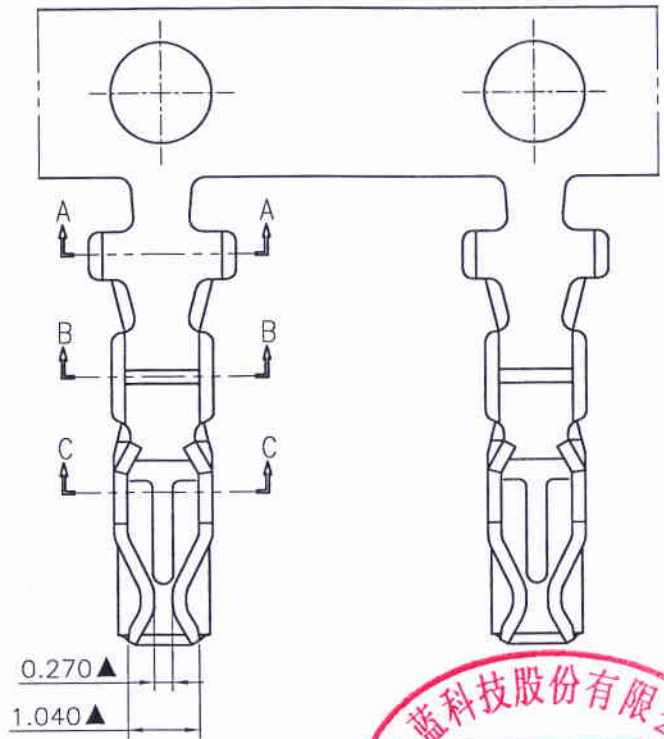
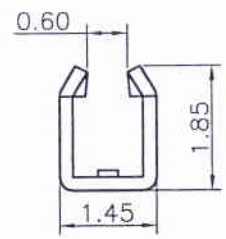

SECTION C-C

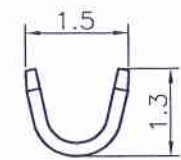

SECTION B-B

12005TOP-XX-XX

- 空码: Mark
- NK: No Mark
- Finish
- 2--Tin-plated(先镀后冲)
- 2E--Tin-plated(先冲后镀)
- Phosphor Bronze
- 外观形态: 180°
- Terminal



Part No	Wire Range	Insulation O.D.	Material	Finish	Qty/reel
12005TOP-2-NK	AWG#24~#28	1.60mm(max)	Phosphor Bronze	Tin-plated	10,000 pcs
12005TOP-2E-NK	AWG#24~#28	1.60mm(max)	Phosphor Bronze	Tin-plated	10,000 pcs

The product using material and processing must conform to the "WI-PZ-142" HSF technical standard control requirements

REV.	REVISION RECORD	DATE	UNIT: MM	GENERAL TOLERANCES		SCALE: 1:1	NAME	DATE	JCTC® 胜蓝科技股份有限公司	PART. NO:	
				LINEAR	ANGLES					12005TOP-XX-XX	
C1	TR1106180100	11.06.18	①	0.0±0.25	X° REF±6°	APPROVED	[Signature]	4/12/17	TERMINAL&CONNECTORS 东莞市富智达电子科技有限公司	DWG. NO:	
C2	TR1107210113	11.07.21	②	0.00±0.15	X° ±3°	DESIGNER	[Signature]	17.12.01		ENDE05	
C3	TN1310230182	13.10.28	③	0.000±0.08	X° X'±2°	DRAWN	伍文聪	17.12.01	TITLE: DF11 端子	REV: C4	SHEET: 1/1
C4	更新公司名称	17.12.01	④								

1 2 3 4 5 6 7 8

A
B
C
D
E
F

G
H