

Specifications:
 Rated Voltage : 250V AC/DC
 Rated Current : 3A AC,DC
 Withstand Voltage : 1000V AC/minute
 Contact Resistance : 20mΩ(MAX.)
 Insulation Resistance : 1000MΩ(MIN.)
 Temperature Range : -25°C~+85°C
 The product using material and processing must conform to the "WI-PZ-142"HSF technical standard control requirements

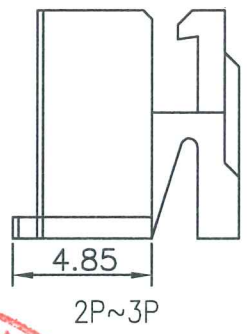

Dimensional Ordering Information:			
Circuits Part No	Dimensions		
	A	B	C
2P	2.50	5.6	7.1
3P	5.00	8.1	9.6
4P	7.50	10.6	12.1
5P	10.00	13.1	14.6
6P	12.50	15.6	17.1
7P	15.00	18.1	19.6
8P	17.50	20.6	22.1
9P	20.00	23.1	24.6
10P	22.50	25.6	27.1
11P	25.00	28.1	29.6
12P	27.50	30.6	32.1
13P	30.00	33.1	34.6
14P	32.50	35.6	37.1
15P	35.00	38.1	39.6
16P	37.50	40.6	42.1

- 12501H00-NP-L-HF
 ① ② ③ ④ ⑤
- ① Series No.
 - ② H90 : Side Contact
H00 : Up Contact
 - ③ No. of Circuits
 - ④ L : Mount type
 - ⑤ HF : Halogen Free

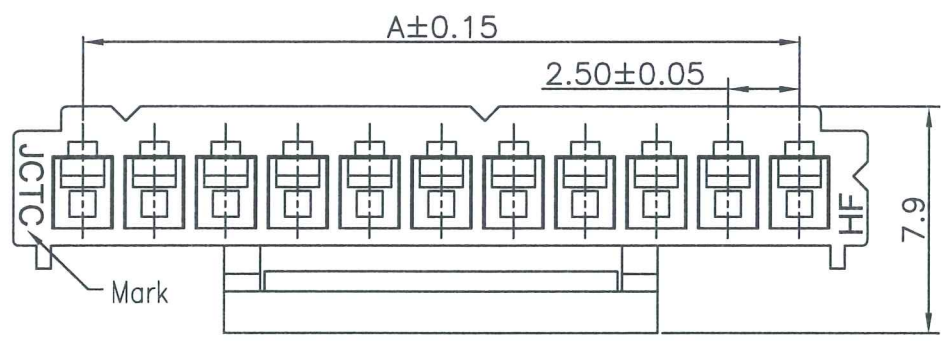
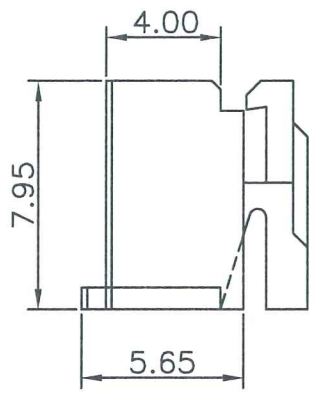
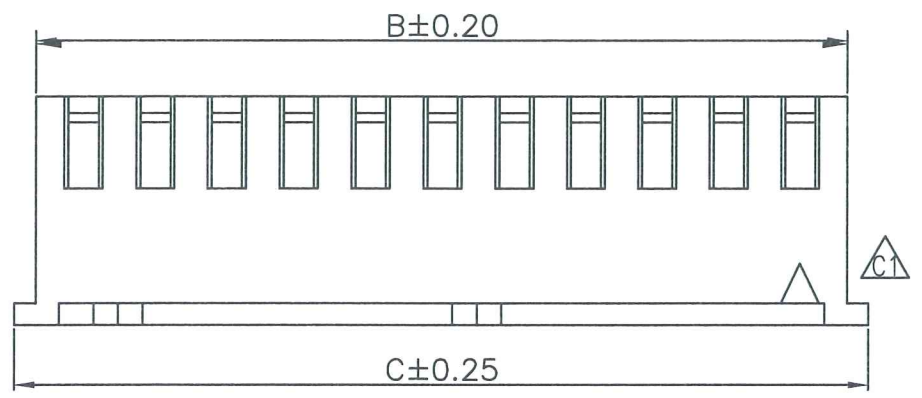

Suitable for JCTC 12501 series terminal

Part No.	Material	Color
12501H00-NP-L	Nylon 66,UL94V-0	本色
12501H00-NP-L-HF	Nylon 66,UL94V-0	无卤材料

REV.	REVISION RECORD	DATE	UNIT: MM SIZE: A4	GENERAL TOLERANCES		SCALE 1:1	NAME	DATE	PART NO.	DWG NO.	 TERMINAL&CONNECTORS
C1	新增第一PIN表示	10.06.09		LINEAR	ANGLES	APPROVED					
C2	HN1104090057	11.04.09	0.0±0.25	X° REF±6°	DESIGNER	Nelson 21.11.16 mu 21.11.16 HZJ 21.11.16	12501H00-NP-L-XX	ENDE05	TITLE XH 带扣 2.50mm PITCH HOUSING		
C3	新增PIN位说明	17.01.03	0.00±0.15	X° ±3°	DRAWN						
C4	更新图框	21.11.16	0.000±0.08	X° X' ±2°						REV C4 SHEET 1/2	

1 2 3 4 5 6 7 8

A

A

B

B

C

C

D

D

E

E

F

F

G

G

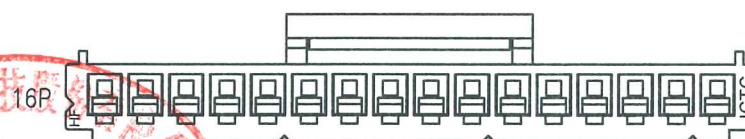
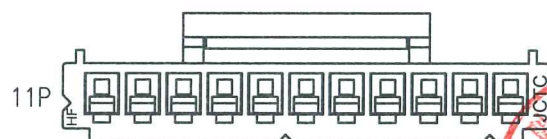
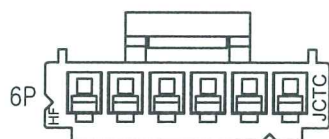
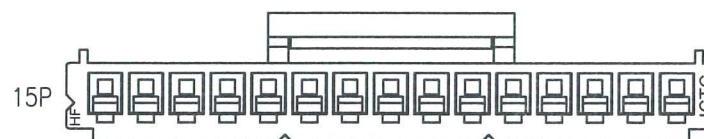
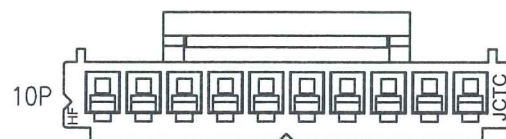
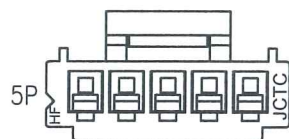
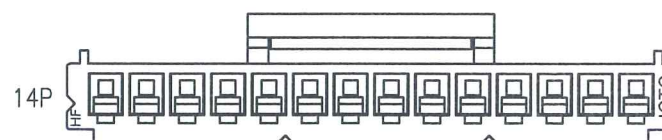
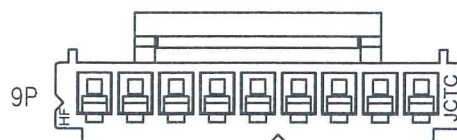
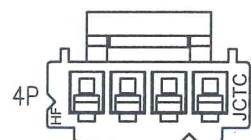
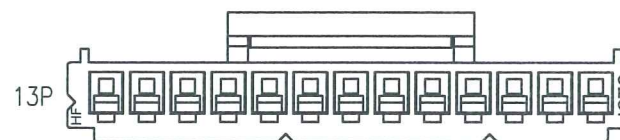
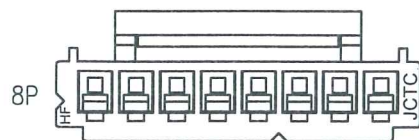
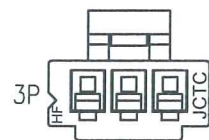
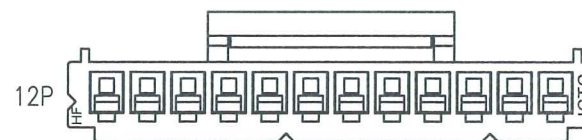
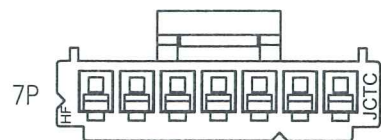
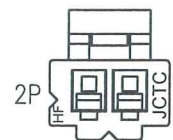

REV.	REVISION RECORD	DATE		GENERAL TOLERANCES		SCALE	NAME	DATE	PART NO.	DWG NO.	 TERMINAL&CONNECTORS			
C1	新增第一PIN位表示	10.06.09		LINEAR	ANGLES	1:1	APPROVED			12501H00-NP-L-XX				
C2	HN1104090057	11.04.09		0.0±0.25	X° REF±6°		DESIGNER	21.11.16	TITLE XH 2.50mm PITCH HOUSING		REV	C4	SHEET	2/2
C3	新增PIN位说明	17.01.03	UNIT: MM	0.00±0.15	X° ±3°		DRAWN	21.11.16						
C4	更新图框	21.11.16	SIZE: A4	0.000±0.08	X° X' ±2°									

1 2 3 4 5 6 7 8