

The product using material and processing must conform to the "WI-PZ-001"HSF technical standard control requirements

RoHS

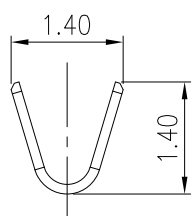

SECTION A-A
SCALE:1:1

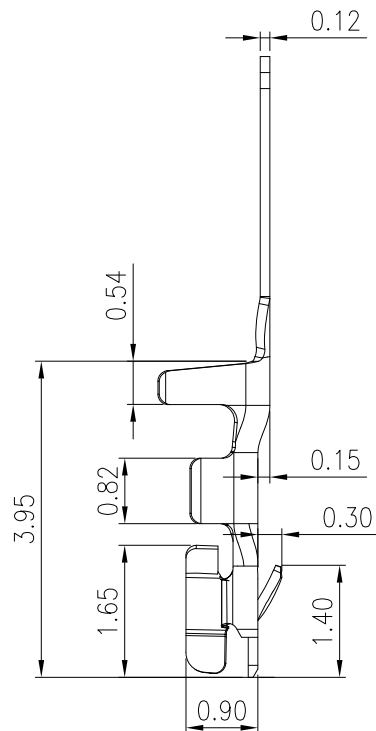
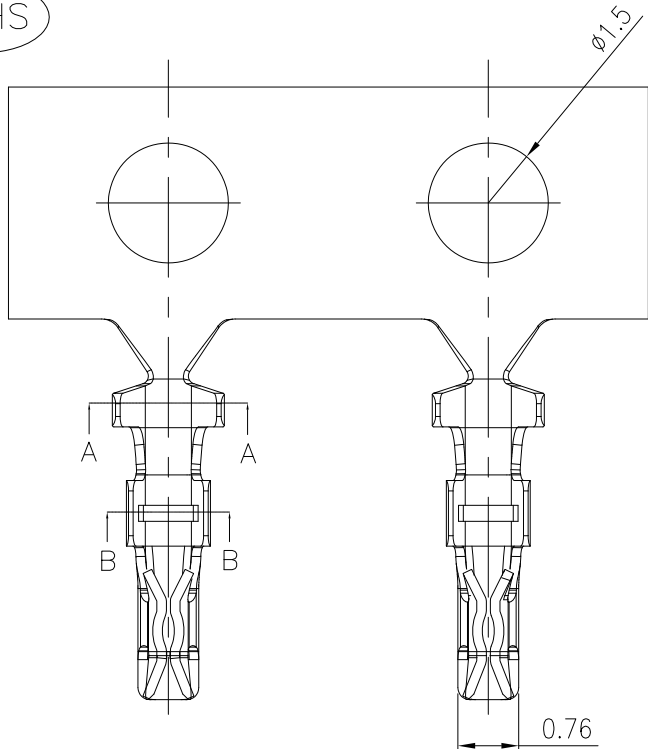
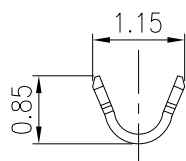

SECTION B-B
SCALE:1:1

- NOTE:
- MATERIAL SPECIFICATION:
 - CONTACTS: PHOSPHOR BRONZE
 - PLATING SPECIFICATION:
 - CONTACTS: TIN/GOLD FLASH PLATED OVER ALL.
 - MECHANICAL PERFORMANCE:
 - RETENTIVITY FORCE: 0.5KGF/Pin Min
 - DURABILITY: 50 CYCLES.
 - ELECTRICAL PERFORMANCE:
 - CURRENT RATING: 1A AC/DC
RATED VOLTAGE : 125V AC/DC
 - CONTACT RESISTANCE: 20 mΩ MAX
 - INSULATION RESISTANCE: 100MΩ Min
 - DIELECTRIC WITHSTANDING : 500V
 - ENVIRONMENTAL PERFORMANCE:
 - OPERATING TEMPERATURE: -25°C~+85°C.
 - PACKAGE SPEC : REEL
 - P/N: A1009 T 1 F X-X

SERIES NO: A1009 T 1 F X-X
 CONNECTOR: T-TERMINAL
 TYPE CODE: X-X
 MALE FEMALE: F-FEMALE M-MALE
 PLATING:
 1-G/F
 A-ALL AU G/F
 C-BRIGHE TIN
 D-MATTE TIN
 METAL:
 P-PHOSPHOR BRONZE
 B-BRASS

REV.	REVISION RECORD	DATE		GENERAL TOLERANCES		SCALE: 1:1	NAME	DATE	PART.NO: A1009T1FX-X	DWG.NO: ENDE05	 WanLian Teconology Co., Ltd
A0	NEW RELEASE	22.10.28		LINEAR	ANGLES	APPROVED	Wang_jr	22.10.28			
			UNIT:mm	0.00±0.25	X°±3°	DESIGNER	Han_Gao	22.10.28	TITLE: Pitch 1.0mm NHB端子 AWG 28#~32#		REV: A0 SHEET: 1/1
			SIZE: A4	0.000±0.10	X°X' ±2°	DRAWN	LanXuan_Hou	22.10.28			