

The product using material and processing must conform to the "WI-PZ-001" HSF technical standard control requirements

RoHS+HF

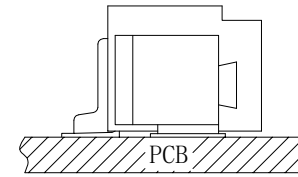
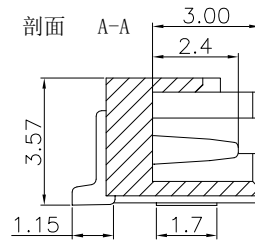
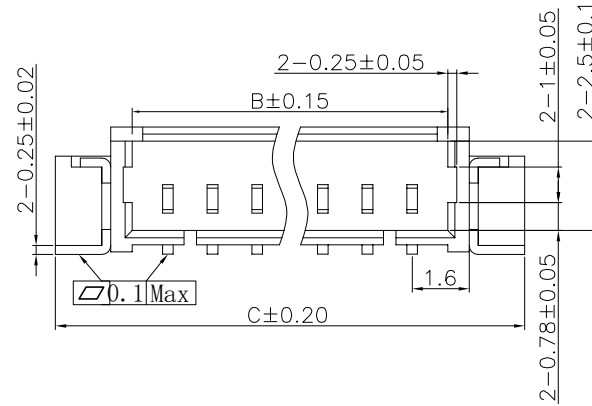
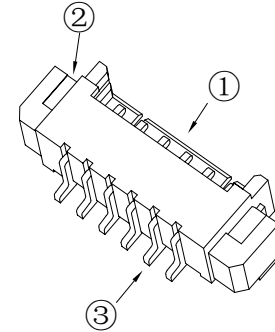
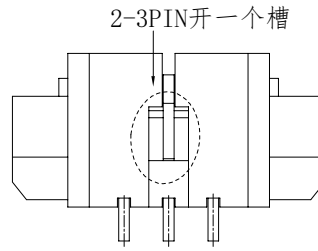
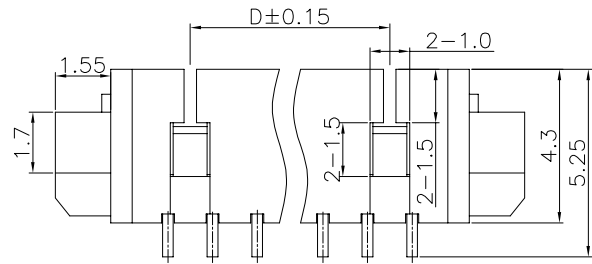

- NOTE:
- MATERIAL SPECIFICATION:
 - HOUSING: LCP, UL94V-0
 - CONTACTS: BRASS
 - PLATING SPECIFICATION:
 - CONTACTS: TIN/GOLD FLASH PLATED OVER ALL.
 - MECHANICAL PERFORMANCE:
 - RETENTIVITY FORCE: 0.7kgf/PIN MIN
 - DURABILITY: 50 CYCLES.
 - ELECTRICAL PERFORMANCE:
 - CURRENT RATING: 1A
 - RATED VOLTAGE: 125V AC/DC
 - CONTACT RESISTANCE: 20 mΩ MAX
 - INSULATION RESISTANCE: 100MΩ Min
 - DIELECTRIC WITHSTANDING: 500V
 - ENVIRONMENTAL PERFORMANCE:
 - OPERATING TEMPERATURE: -25°C~+85°C.
 - PACKAGE SPEC: REEL
 - P/N ORDER:

SERIES NO: A1251 W 9-1 XX 2 X X 0

 CONNECTOR: W-WAFER

 ANGLE: 9-90°

 ROW NO: 1-SINGLE ROW

 PIN Q'PY: 02~16

 COLOR: A-BLACK, M-BEIGE

 PLATING: A-ALL AU G/F, C-BRIGHT TIN, D-MATTE TIN

 TERMPIPOINT: 2-SMT

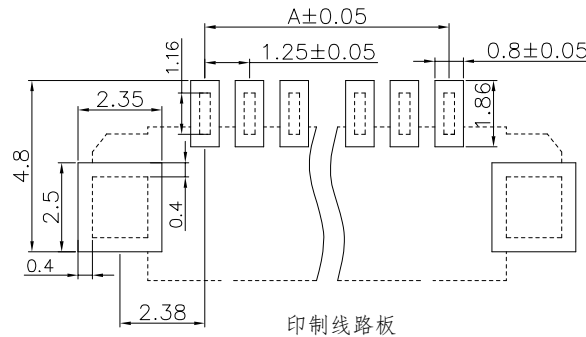
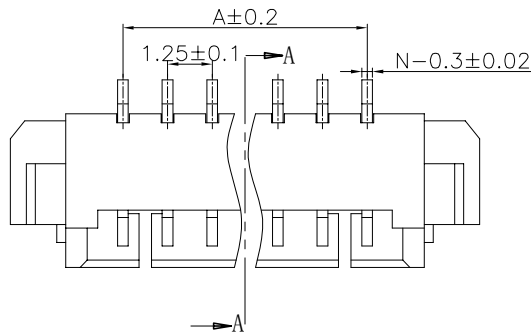

| 物料名称 | 数量 (PCS) | 材质 | 镀涂 |
|------|----------|-----|----|
| 塑胶件 | 1 PCS | LCP | 本色 |
| 焊片 | 2 PCS | 黄铜 | 亮锡 |
| PIN针 | 2-16 PCS | 黄铜 | 亮锡 |

Ordering Information & Dimensions

| Circuit | Dimensions(mm) | | | | Circuit | Dimensions(mm) | | | |
|---------|----------------|-------|-------|------|---------|----------------|-------|-------|-------|
| | A | B | C | D | | A | B | C | D |
| 02 | --- | 3.10 | 7.50 | / | 10 | 11.25 | 13.10 | 17.60 | 10.00 |
| 03 | 2.50 | 4.35 | 8.80 | / | 11 | 12.50 | 14.35 | 18.80 | 11.25 |
| 04 | 3.75 | 5.60 | 10.00 | 2.50 | 12 | 13.75 | 15.60 | 20.10 | 12.50 |
| 05 | 5.00 | 6.85 | 11.30 | 3.75 | 13 | 15.00 | 16.85 | 21.30 | 13.75 |
| 06 | 6.25 | 8.10 | 12.60 | 5.00 | 14 | 16.25 | 18.10 | 22.55 | 15.00 |
| 07 | 7.50 | 9.35 | 13.80 | 6.25 | 15 | 17.50 | 19.35 | 23.80 | 16.25 |
| 08 | 8.75 | 10.60 | 15.00 | 7.50 | 16 | 18.75 | 20.60 | 25.05 | 17.50 |
| 09 | 10.00 | 11.85 | 16.30 | 8.75 | | | | | |

| REV. | REVISION RECORD | DATE | GENERAL TOLERANCES | | SCALE: | NAME | DATE | PART. NO: A1251W9-1XX2XX0 | DWG. NO: ENDE05 | 万连科技 WanLian Technology Co., Ltd |
|------|---------------------|------------|--------------------|-----------|--------|---------|----------|------------------------------|--------------------|---|
| A0 | NEW RELEASE | 2021.03.16 | LINEAR | ANGLES | 1:1 | Wang_jr | 23.09.14 | | | |
| A1 | PART NUMBER RENEWAL | 23.09.14 | 0.00±0.35 | X° REF±6° | | Ding_bo | 23.09.14 | | | |
| | | | 0.00±0.25 | X° ±3° | | HXY | 23.09.14 | | | |
| | | | 0.000±0.10 | X° X'±2° | | | | | | |

UNIT: mm
SIZE: A4
TITLE: WAFER PITCH 1.25mm 卧贴

REV: A1 SHEET: 1/3

The product using material and processing must conform to the "WI-PZ-001"HSF technical standard control requirements

RoHS+HF

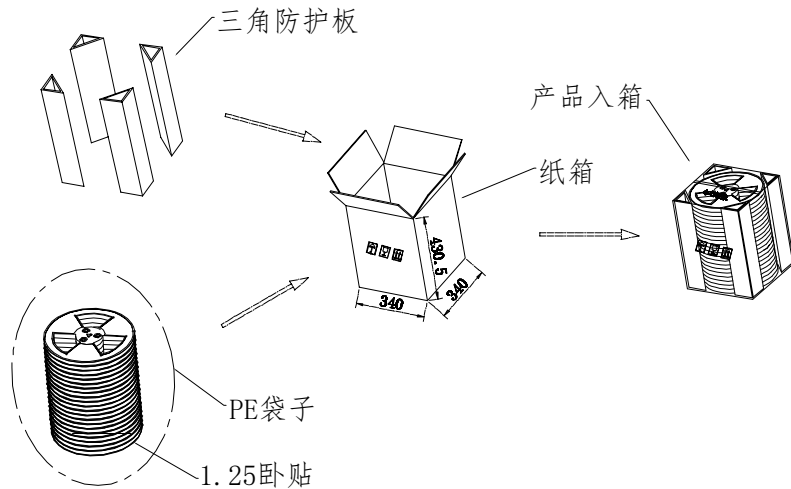
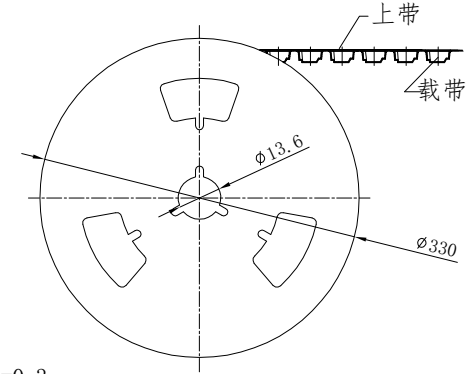
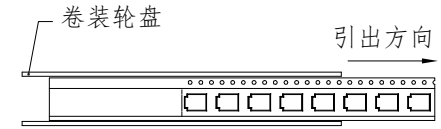
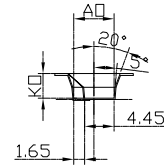
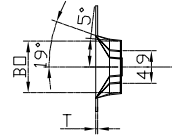
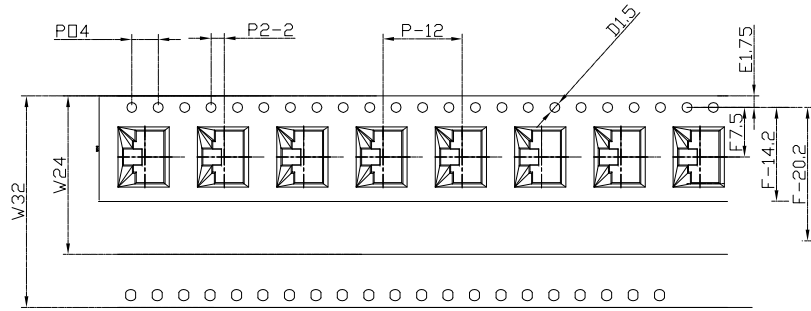

备注:

- 材料: 载带PS 雾透色 $t=0.3$
 热封/自粘上盖带: PET $t=0.05\text{mm}$.
 纸箱: 纤维板、波纹、双墙, 黄色。
 卷盘: 聚苯乙烯, 耐热温度: 70°C , 蓝色。
- PET膜剥离力: $30\sim 70\text{g}$, 剥离速度: $300\text{mm}/\text{分钟}$ 。
- 带子前后预留:

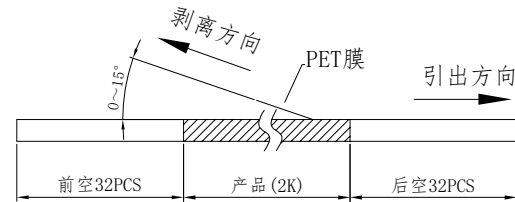

| 载带尺寸 | | | |
|------|------|-------|-------|
| PIN位 | W | B0 | F |
| 2P | 16.0 | 7.80 | 7.50 |
| 3P | 16.0 | 9.05 | 7.50 |
| 4P | 24.0 | 10.30 | 11.50 |
| 5P | 24.0 | 11.55 | 11.50 |
| 6P | 24.0 | 12.80 | 11.50 |
| 7P | 24.0 | 14.05 | 11.50 |
| 8P | 24.0 | 15.30 | 11.50 |
| 9P | 24.0 | 16.55 | 11.50 |
| 10P | 32.0 | 17.80 | 14.20 |
| 12P | 32.0 | 20.30 | 14.20 |

| 卷装包装明细 | | | |
|---------|-------|------|------|
| | 每卷包装数 | 每件盘数 | 每件数量 |
| 02P~03P | 2K | 20盘 | 40K |
| 04P~09P | 2K | 14盘 | 28K |
| 10P | 2K | 11盘 | 22K |
| 12P | 2K | 11盘 | 22K |

| REV. | REVISION RECORD | DATE | GENERAL TOLERANCES | | SCALE: | NAME | DATE | PART. NO: | DWG. NO: |
|------|---------------------|------------|--------------------|------------|-----------|-----------|----------|----------------------------|----------|
| A0 | NEW RELEASE | 2021.03.16 | LINEAR | ANGLES | 1:1 | Wang_jr | 23.09.14 | A1251W9-1XX2XX0 | ENDE05 |
| A1 | PART NUMBER RENEWAL | 23.09.14 | | | 0.00±0.35 | X° REF±6° | APPROVED | Ding_bo | 23.09.14 |
| | | | UNIT: mm | X° ±3° | DESIGNER | HXY | 23.09.14 | WAFER PITCH 1.25mm 卧贴 包装规范 | |
| | | | SIZE: A4 | 0.000±0.10 | DRAWN | | | | |

WanLian Technology Co., Ltd

REV: A1 SHEET: 2/3

The product using material and processing must conform to the "WI-PZ-001"HSF technical standard control requirements

RoHS+HF

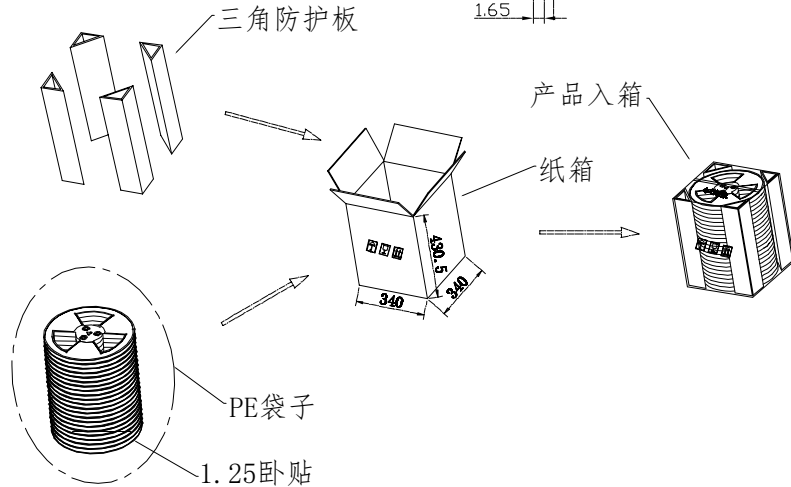
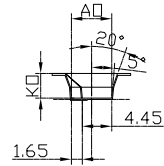
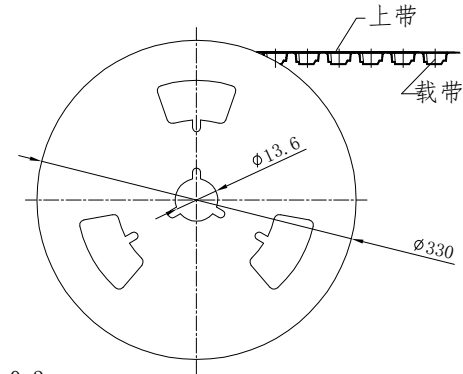
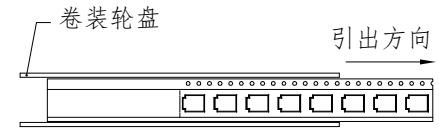
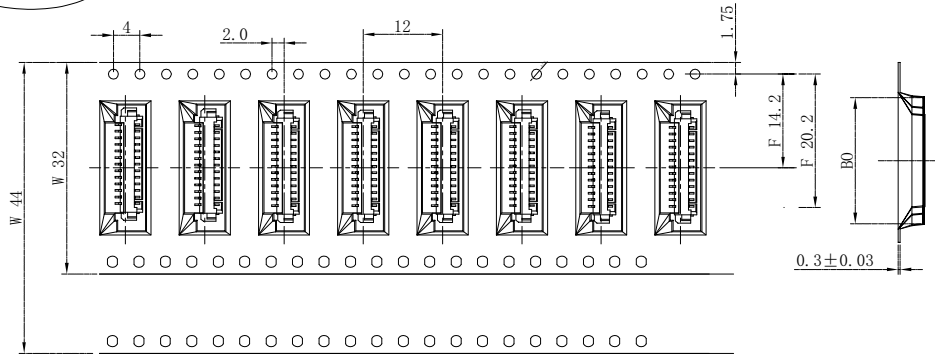

备注:

- 材料: 载带PS 雾透色 t=0.3
热封/自粘上盖带: PET t=0.05mm.
纸箱: 纤维板、波纹、双墙,黄色。
卷盘: 聚苯乙烯, 耐热温度: 70℃, 蓝色。
- PET膜剥离力: 30~70g, 剥离速度: 300mm/分钟。
- 带子前后预留:

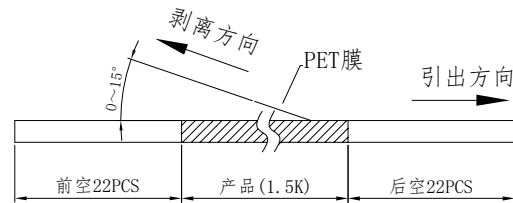

| 载带尺寸 | | | |
|------------|------|-------|------|
| PIN位 | W | B0 | F |
| 1.25WT-11P | 32.0 | 19.05 | 14.2 |
| 1.25WT-13P | 32.0 | 21.55 | 14.2 |
| 1.25WT-14P | 44.0 | 22.80 | 20.2 |
| 1.25WT-15P | 44.0 | 24.05 | 20.2 |
| 1.25WT-16P | 44.0 | 25.30 | 20.2 |

| 卷装包装明细 | | | |
|---------|-------|------|-------|
| PIN位 | 每卷包装数 | 每件盘数 | 每件数量 |
| 11P | 1.5K | 11盘 | 16.5K |
| 13P | 1.5K | 11盘 | 16.5K |
| 14P~16P | 1.5K | 8盘 | 12K |

| REV. | REVISION RECORD | DATE | GENERAL TOLERANCES | | SCALE: | NAME | DATE | PART. NO: | DWG. NO: |
|------|---------------------|------------|--------------------|------------|-----------|----------|----------|-----------------|----------------------------|
| A0 | NEW RELEASE | 2021.03.16 | | LINEAR | 1:1 | Wang_jr | 23.09.14 | A1251W9-1XX2XX0 | ENDE05 |
| A1 | PART NUMBER RENEWAL | 23.09.14 | | ANGLES | | | | | |
| | | | | 0.0±0.35 | X° REF±6° | DESIGNER | Ding_bo | TITLE: | WAFER PITCH 1.25mm 卧贴 包装规范 |
| | | | | UNIT: mm | 0.00±0.25 | X° ±3° | DRAWN | | |
| | | | SIZE: A4 | 0.000±0.10 | X° X'±2° | | | | |



WanLian Technology Co., Ltd