

The product using material and processing must conform to the "WI-PZ-001"HSF technical standard control requirements

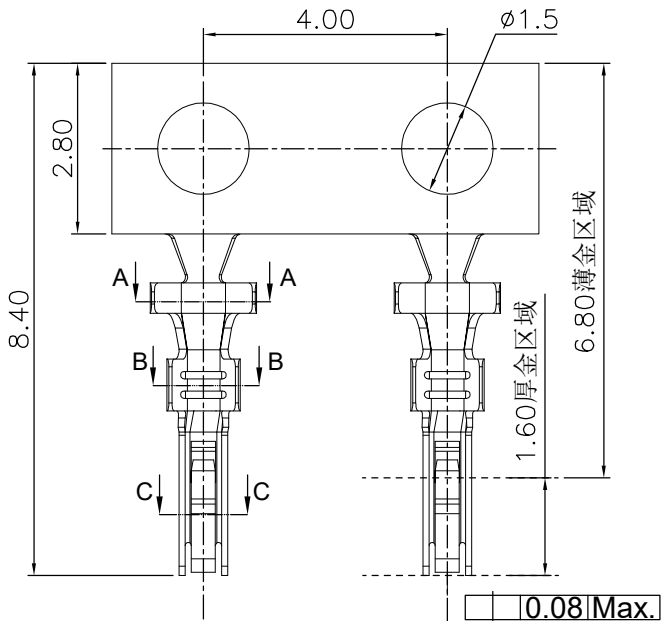

中间弹片不能与两边干涉

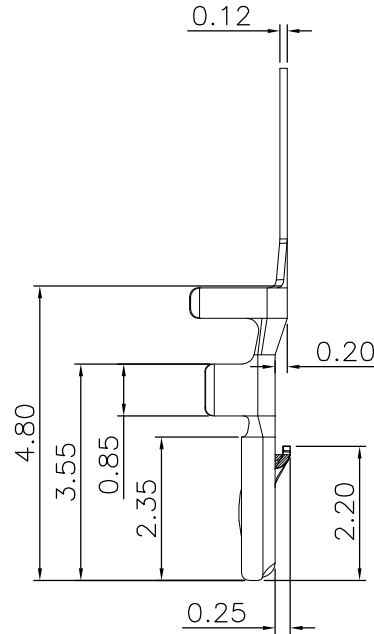

NOTE:

- 1.MATERIAL SPECIFICATION:  
1-1.TERMINAL: PHOSPHOR BRONZE
- 2.PLATING SPECIFICATION:  
2-1.TERMINAL:  
TIN/GOLD FLASH PLATED OVER ALL.
- 3.ELECTRICAL PERFORMANCE:  
3-1.CURRENT RATING: 1A AC/DC  
3-2.CONTACT RESISTANCE: 30 mΩ MAX  
3-3.INSULATION RESISTANCE: 100MΩ Min  
3-4.DIELECTRIC WITHSTANDING : 500V
- 4.ENVIRONMENTAL PERFORMANCE:  
4-1.OPERATING TEMPERATURE: -25°C~+85°C.
- 5.PACKAGE SPEC: REEL
- 6.P/N:

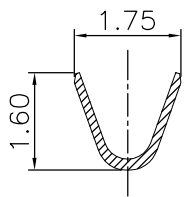
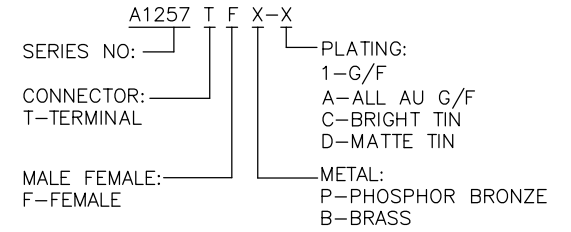

SECTION:A-A

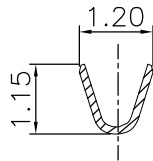

SECTION:B-B

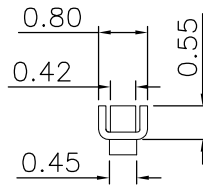

SECTION:C-C

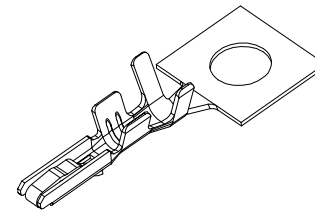

3D VIEW

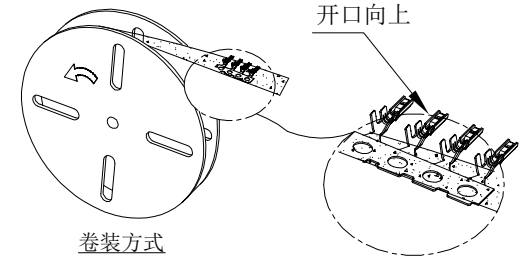

Ordering Information & Specifications

Wire Range	Insulation O.D.	Qty/reel
AWG#26-#30	1.00mm(max)	15,000pcs

REV.	REVISION RECORD	DATE	UNIT:mm	GENERAL TOLERANCES		SCALE: 1:1	NAME	DATE	PART.NO:	DWG.NO:	 WanLian Technology Co., Ltd
AO	NEW RELEASE	22.07.07		LINEAR	ANGLES	APPROVED	Wang_jr	22.07.07	A1257TFX-X	ENDE05	
			0.0±0.35	X'REF±6°	DESIGNER	Han_Gao	22.07.07	TITLE: Pitch 1.25mm GH端子 AWG#26~#30		REV: A0	SHEET: 1/1
			0.00±0.25	X'±3°	DRAWN	LanXuan_Hou	22.07.07				
			0.000±0.10	X'X' ±2°							