

The product using material and processing must conform to the "WI-PZ-142"HSF technical standard control requirements

RoHS+HF

NOTE:

- MATERIAL SPECIFICATION:
 - HOUSING:LCP NATURE UL94V-0
 - SOLDER TABS:PHOSPHOR BRONZE
 - CAP:LCP NATURE UL94V-0
 - CONTACTS:PHOSPHOR BRONZE
- PLATING SPECIFICATION:
 - CONTACTS: TIN/AU PLATED OVER ALL.
- ELECTRICAL PERFORMANCE:
 - RATED CURRENT : 1A AC,DC
 - INSULATION RESISTANCE: 100MΩ MIN
 - CONTACT RESISTANCE : 30mΩ(MAX.)
 - WITHSTANDING VOLTAGE: 500V AC/minute
- ENVIRONMENTAL PERFORMANCE:
 - OPERATING TEMPERATURE: -40°C~+105°C.
- PACKAGE SPEC: REEL
- P/N:

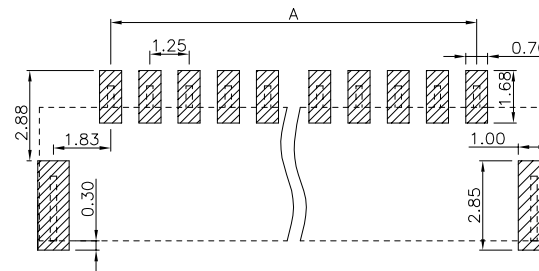
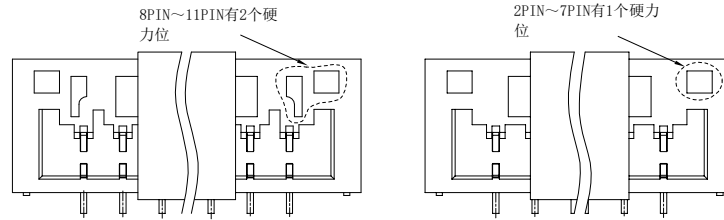
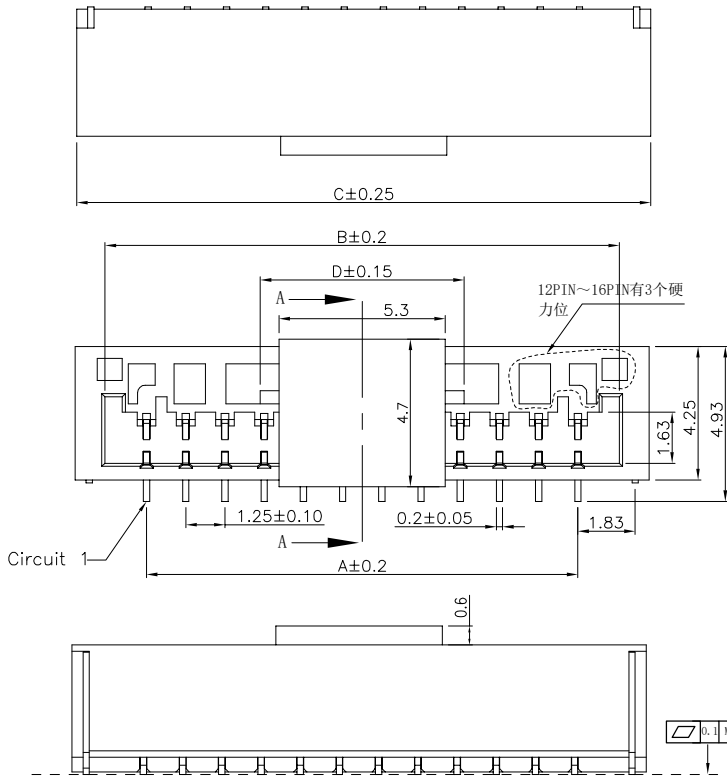

RECOMMENDED PCB LAYOUT
(GENERAL TOLERANCE:±0.05)

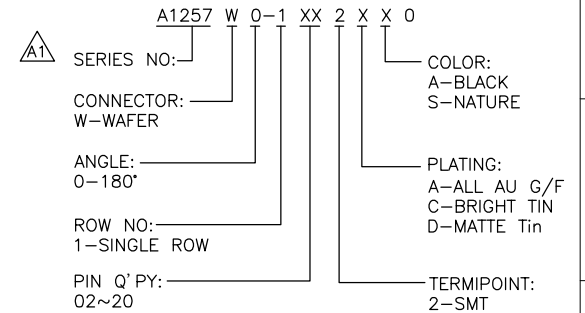

Ordering Information & Dimensions

Circuit	Dimensions(mm)				Circuit	Dimensions(mm)			
	A	B	C	D		A	B	C	D
02	1.25	3.85	5.80	0.50	12	13.75	16.35	18.30	6.50
03	2.50	5.10	7.05	1.75	13	15.00	17.60	19.55	6.50
04	3.75	6.35	8.30	2.00	14	16.25	18.85	20.80	6.50
05	5.00	7.60	9.55	3.26	15	17.50	20.10	22.05	6.50
06	6.25	8.85	10.80	4.52	16	18.75	21.35	23.30	6.50
07	7.50	10.10	12.05	4.50	17	20.00	22.60	24.55	6.50
08	8.75	11.35	13.30	4.50	18	21.25	23.85	25.80	6.50
09	10.00	12.60	14.55	4.50	19	22.50	25.10	27.05	6.50
10	11.25	13.85	15.80	6.50	20	23.75	26.35	28.30	6.50
11	12.50	15.10	17.05	6.50					

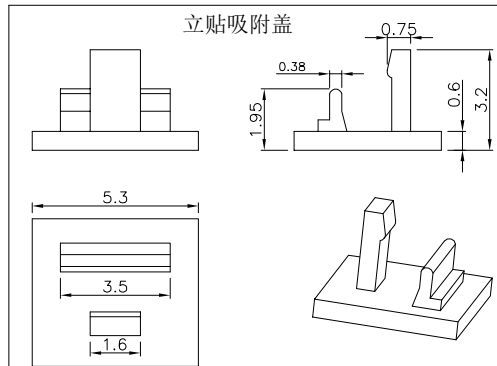
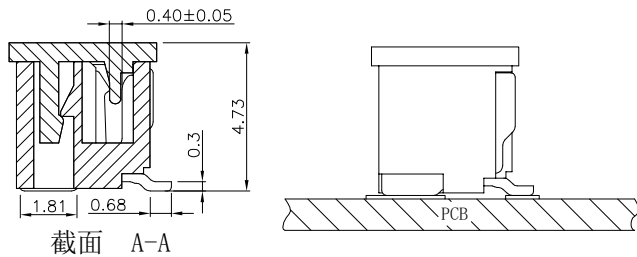

REV.	REVISION RECORD	DATE		GENERAL TOLERANCES		SCALE:	NAME	DATE	PART.NO:	DWG.NO:	
A0	NEW RELEASE	21.01.13		LINEAR	ANGLES	1:1					
A1	PART NUMBER RENEWAL	23.09.19		0.00±0.25	X°±3'	DESIGNER	Ou_jian	23.09.19	TITLE:	GH1.25 VERTICAL CONNECTOR	WanLian Technology Co., Ltd REV: A1 SHEET: 1/2
				0.00±0.10	X°X'±2'	DRAWN					

The product using material and processing must conform to the "WI-PZ-142"HSF technical standard control requirements

RoHS+HF

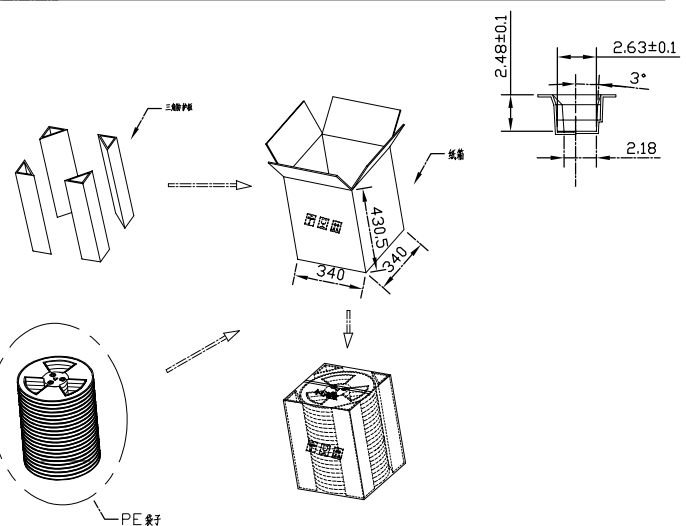
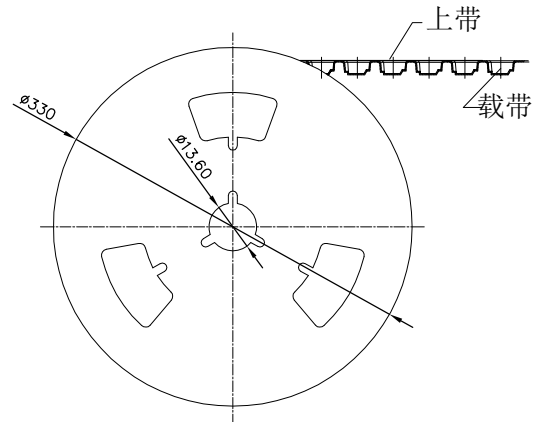
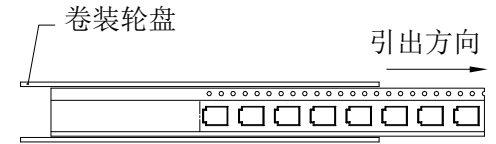
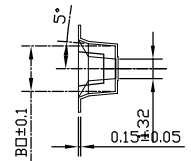
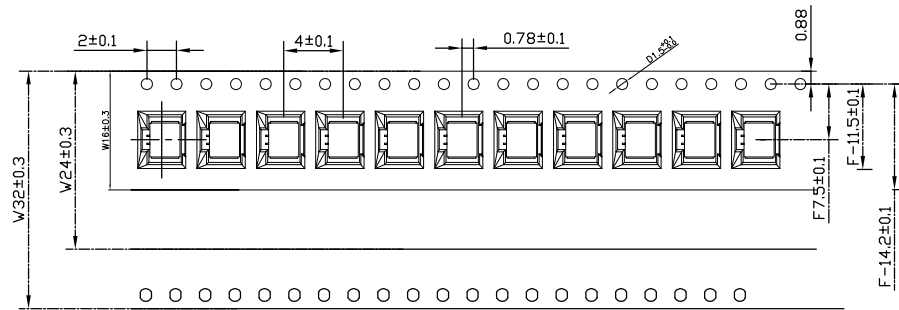

1. 上带剥离力: $A | 15^\circ \sim 0^\circ$
 $F | 20^\circ \sim 70^\circ (g)$
2. 带子预空格:

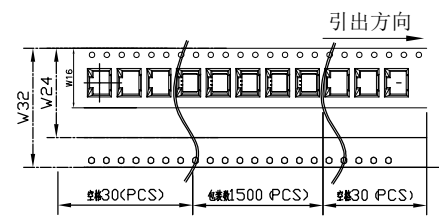

3. 载带材料规格: PS 白色料抗静电, 厚度 0.30mm.

Circuits	载带尺寸			Circuits	载带尺寸			包装规格列表			
	W	B0	F		W	B0	F	PIN位	每卷包装数	每件数量	每件数量
02P	16.0	6.10	7.50	012P	32.0	18.6	14.2	02P-04P	1500(PCS)	20 (K)	30(K)
03P	16.0	7.35	7.50					05P-10P	1500(PCS)	14 (K)	21(K)
04P	16.0	8.60	7.50					11P-14P	1500(PCS)	11 (K)	16.5(K)
05P	24.0	9.85	11.50					15P-16P	1500(PCS)	8 (K)	12(K)
06P	24.0	11.10	11.50								
07P	24.0	12.35	11.50								
08P	24.0	13.60	11.50								
09P	24.0	14.85	11.50								
010P	24.0	16.10	11.50								
011P	32.0	17.35	14.20								

REV.	REVISION RECORD	DATE	GENERAL TOLERANCES	SCALE:	NAME	DATE	PART.NO:	DWG.NO:	 WanLian Technology Co., Ltd
A0	NEW RELEASE	21.01.13	LINEAR	1:1	Wang_jr	23.09.19	A1257W0-1XX2XX0	ENDE05	
A1	PART NUMBER RENEWAL	23.09.19	ANGLES	APPROVED	Ding_bo	23.09.19	TITLE:	GH1.25 VERTICAL CONNECTOR	
			0.00±0.35	DESIGNER	Ou_jian	23.09.19			
			X°REF±6°	DRAWN					
			0.00±0.25						
			X'±3°						
			0.000±0.10						
			X'X' ±2°						
			UNIT:mm						
			SIZE: A4						

REV: A1 SHEET: 2/2