

The product using material and processing must conform to the "WI-PZ-142"HSF technical standard control requirements

RoHS+HF

NOTE:
 1.MATERIAL SPECIFICATION:
 1-1.HOUSING:LCP NATURE UL94V-0
 1-2.SOLDER TABS:PHOSPHOR BRONZE
 1-3.CONTACTS:PHOSPHOR BRONZE
 2.PLATING SPECIFICATION:
 2-1.CONTACTS:
 TIN/AU PLATED OVER ALL.
 4.ELECTRICAL PERFORMANCE:
 4-1. RATED CURRENT : 1A AC,DC
 4-2.INSULATION RESISTANCE: 100MΩ MIN
 4-3.CONTACT RESISTANCE : 30mΩ(MAX.)
 4-4.WITHSTANDING VOLTAGE: 500V AC/minute
 5.ENVIRONMENTAL PERFORMANCE:
 OPERATING TEMPERATURE: -40°C~+105°C.
 6.PACKAGE SPEC: REEL
 7.P/N:

 SERIES NO: A1257 W 9-1 XX 2 X X 0
 CONNECTOR: W-WAFER
 ANGLE: 9-90°
 ROW NO: 1-SINGLE ROW
 PIN Q' PY: 02~20
 COLOR:
 A-BLACK
 S-NATURE
 PLATING:
 A-ALL AU G/F
 C-BRIGHT TIN
 D-MATTE TIN
 TERMPIENT:
 2-SMT

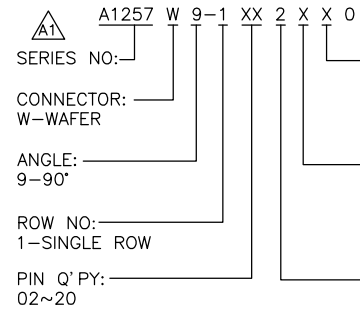
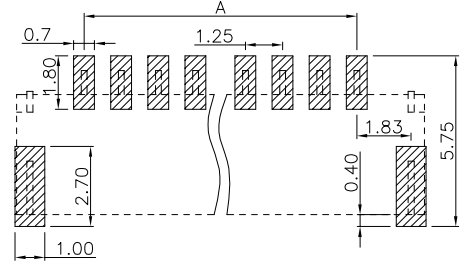
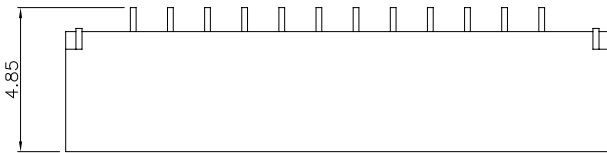
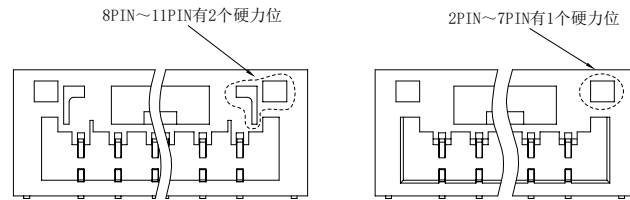
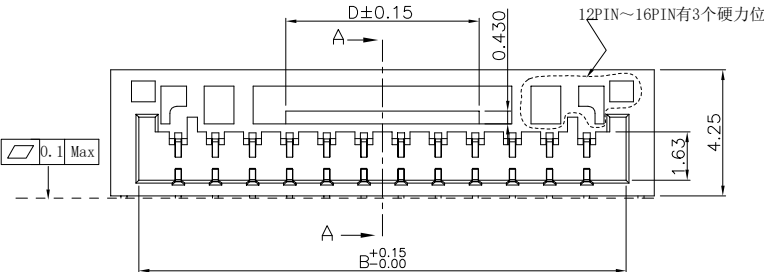
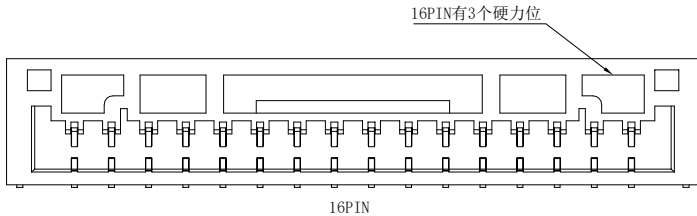
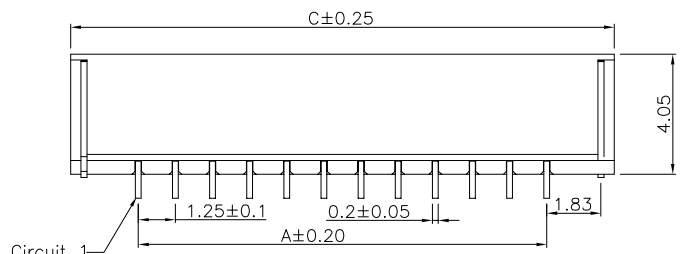

RECOMMENDED PCB LAYOUT
(GENERAL TOLERANCE:±0.05)

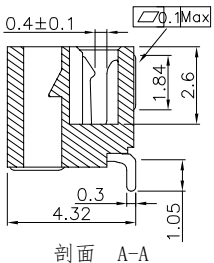
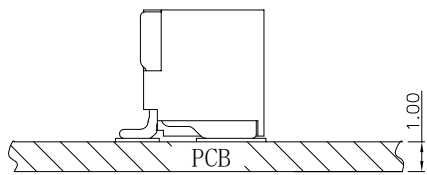

Ordering Information & Dimensions

Circuit	Dimensions(mm)				Circuit	Dimensions(mm)			
	A	B	C	D		A	B	C	D
02	1.25	3.85	5.80	0.50	12	13.75	16.35	18.30	6.50
03	2.50	5.10	7.05	1.75	13	15.00	17.60	19.55	6.50
04	3.75	6.35	8.30	2.00	14	16.25	18.85	20.80	6.50
05	5.00	7.60	9.55	3.26	15	17.50	20.10	22.05	6.50
06	6.25	8.85	10.80	4.52	16	18.75	21.35	23.30	6.50
07	7.50	10.10	12.05	4.50	17	20.00	22.60	24.55	6.50
08	8.75	11.35	13.30	4.50	18	21.25	23.85	25.80	6.50
09	10.00	12.60	14.55	4.50	19	22.50	25.10	27.05	6.50
10	11.25	13.85	15.80	6.50	20	23.75	26.35	28.30	6.50
11	12.50	15.10	17.05	6.50					

REV.	REVISION RECORD	DATE	GENERAL TOLERANCES		SCALE:	NAME	DATE	PART.NO:	DWG.NO:	 WanLian Technology Co., Ltd REV: A1 SHEET: 1/2
A0	NEW RELEASE	21.01.13	LINEAR	ANGLES	1:1				ENDE05	
A1	PART NUMBER RENEWAL	23.09.19	0.0±0.35	X'REF±6°	APPROVED	Wang_jr	23.09.19	A1257W9-1XX2XX0		
			0.00±0.25	X'±3°	DESIGNER	Ding_bo	23.09.19	TITLE: GH1.25 FLAT ATTACHMENT CONNECTOR		
			UNIT:mm	X'X' ±2°	DRAWN	Ou_jian	23.09.19			
			SIZE: A4	0.000±0.10						

The product using material and processing must conform to the "WI-PZ-142"HSF technical standard control requirements

RoHS+HF

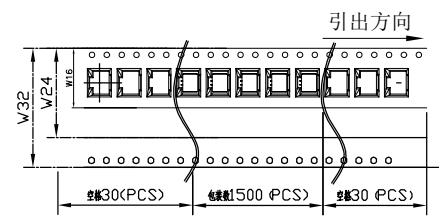
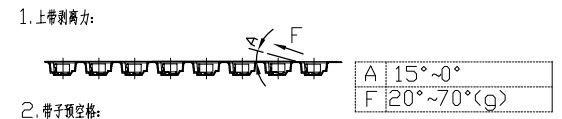
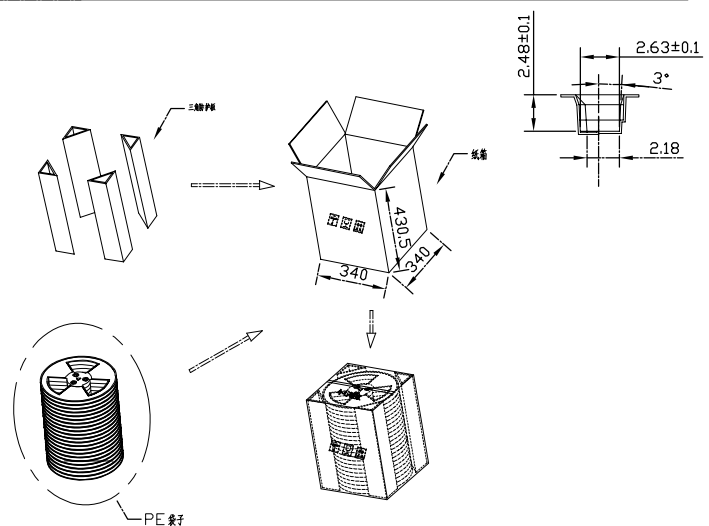
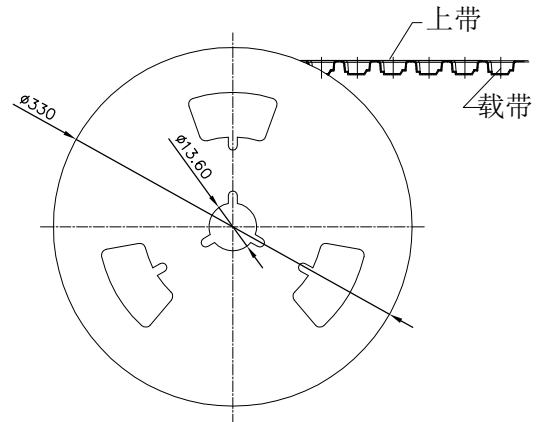
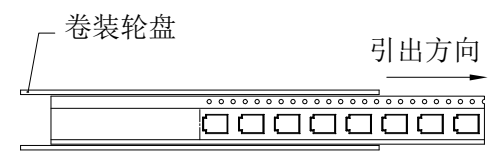
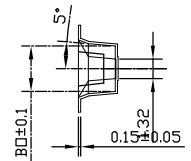
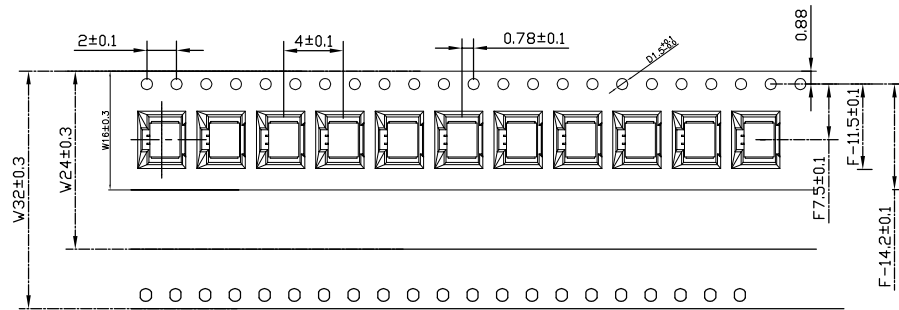

Circuits	载带尺寸			Circuits	载带尺寸			卷装包装明细表			
	W	B0	F		W	B0	F	PIN位	每卷包装数	每件盘数	每件数量
02P	16.0	6.10	7.50	012P	32.0	18.6	14.2	02P-04P	1500(PCS)	20 (盘)	30(K)
03P	16.0	7.35	7.50					05P-10P	1500(PCS)	14 (盘)	21(K)
04P	16.0	8.60	7.50					11P-14P	1500(PCS)	11 (盘)	16.5(K)
05P	24.0	9.85	11.50					15P-16P	1500(PCS)	8 (盘)	12(K)
06P	24.0	11.10	11.50								
07P	24.0	12.35	11.50								
08P	24.0	13.60	11.50								
09P	24.0	14.85	11.50								
10P	24.0	16.10	11.50								
11P	32.0	17.35	14.20								

REV.	REVISION RECORD		DATE		GENERAL TOLERANCES		SCALE: 1:1	NAME	DATE	PART.NO:	DWG.NO:	 WanLian Technology Co., Ltd
A0	NEW RELEASE		21.01.13		LINEAR	ANGLES	APPROVED	Wang_jr	23.09.19	A1257W9-1XX2XX0		
A1	PART NUMBER RENEWAL		23.09.19	UNIT:mm	0.00±0.25	X'±3'	DESIGNER	Ding_bo	23.09.19	TITLE:		REV: A1 SHEET: 2/2
				SIZE: A4	0.000±0.10	X'X' ±2'	DRAWN	Ou_jian	23.09.19	GH1.25 VERTICAL CONNECTOR		