

The product using material and processing must conform to the "WL-PZ-001"HSF technical standard control requirements

RoHS+HF

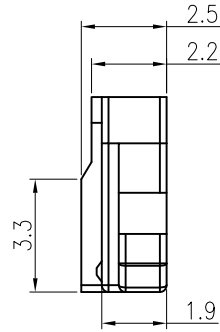
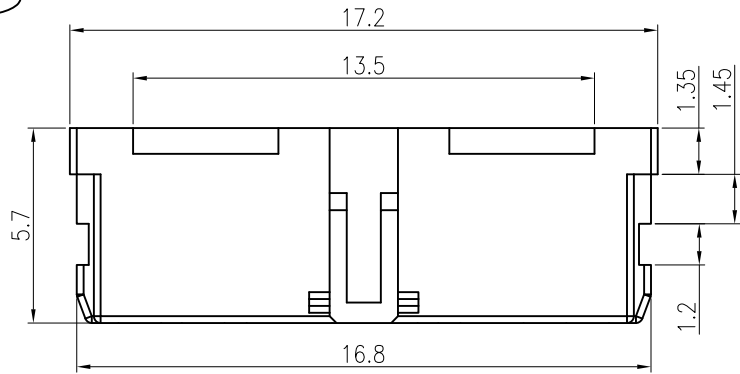

NOTE:

- 1.MATERIAL SPECIFICATION:
1-1.HOUSING: PA66,UL94V-0
- 2.MECHANICAL PERFORMANCE:
2-1.RETENTIVITY FORCE: 0.5KGF/pin min
2-2.DURABILITY: 30 CYCLES.
- 3.ELECTRICAL PERFORMANCE:
3-1.CURRENT RATING: 2.5A AC/DC
RATED VOLTAGE : 200V AC/DC
3-2.CONTACT RESISTANCE: 20 mΩ MAX
3-3.INSULATION RESISTANCE: 100MΩ Min
3-4.DIELECTRIC WITHSTANDING : 500V
- 4.ENVIRONMENTAL PERFORMANCE:
4-1.OPERATING TEMPERATURE: -40°C~+80°C.
- 5.PACKAGE SPEC: PE BAG

6.P/N: A125A H 1 M-1 12 X 0

SERIES NO: _____
CONNECTOR: _____
H-HOUSING
TYPE CODE: _____
MALE FEMALE: _____
M-MALE

COLOR:
A-BLACK
K-WHITE
S-NATURE

PIN Q'PY:
12PIN
ROW NO:
1-SINGLE ROW

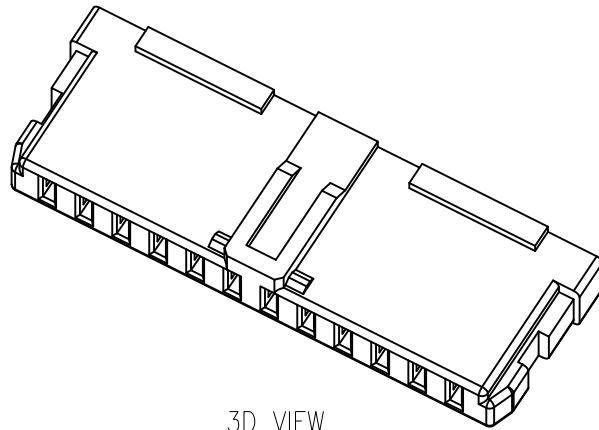
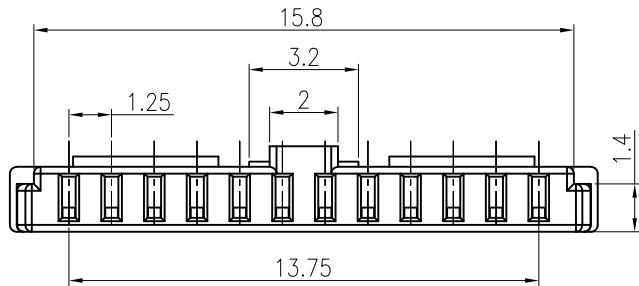

3D VIEW

REV.	REVISION RECORD	DATE	GENERAL TOLERANCES		SCALE:	NAME	DATE	PART.NO:	DWG.NO:
AO	NEW RELEASE	21.11.17		LINEAR	1:1	Wang_jr	21.11.17	A125AH1M-112X0	ENDE05
				ANGLES	APPROVED				
			UNIT:mm	0.0±0.35	X'REF±6°	Han_Gao	21.11.17	TITLE:	Pitch 1.25mm 单排带扣加厚Housing
				0.00±0.25					
			SIZE: A4	0.000±0.10	X'X' ±2°	DRAWN	Zijun_Huang	21.11.17	



WanLian Teconology Co., Ltd
REV: AO SHEET: 1/1