

The product using material and processing must conform to the "WI-PZ-001"HSF technical standard control requirements

RoHS

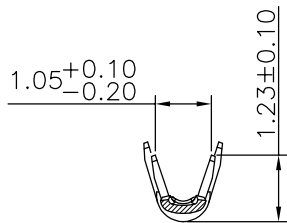

SECTION B-B

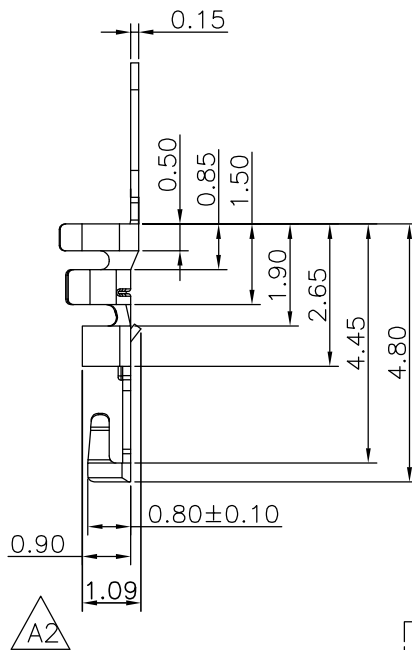
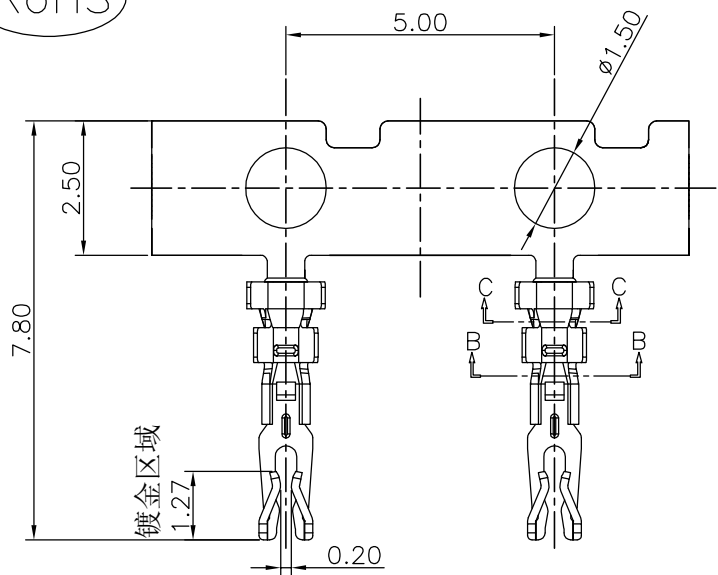
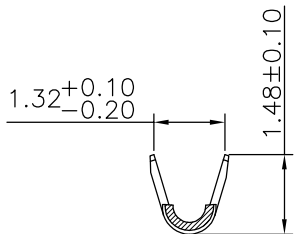

SECTION C-C

NOTE:

- 1.MATERIAL SPECIFICATION:
1-1.CONTACTS: PHOSPHOR BRONZE
- 2.PLATING SPECIFICATION:
2-1.CONTACTS:
TIN/GOLD FLASH PLATED OVER ALL.
- 3.ELECTRICAL PERFORMANCE:
3-1.CURRENT RATING: 2.5A
RATED VOLTAGE : 200V AC/DC
3-2.CONTACT RESISTANCE: 20 mΩ MAX
3-3.INSULATION RESISTANCE: 100 MΩ Min
3-4.DIELECTRIC WITHSTANDING : 500V
- 4.ENVIRONMENTAL PERFORMANCE:
4-1.OPERATING TEMPERATURE: -40°C~+80°C.
- 5.PACKAGE SPEC:16K/REEL
- 6.P/N:

SERIES NO: A125A T F X-X
 CONNECTOR: T-TERMINAL
 MALE FEMALE: F-FEMALE M-MALE
 PLATING:
 E-G/F BRIGHT TIN
 B-ALL 5U"AU
 H-ALL 15U"AU
 METAL:
 P-PHOSPHOR BRONZE
 B-BRASS

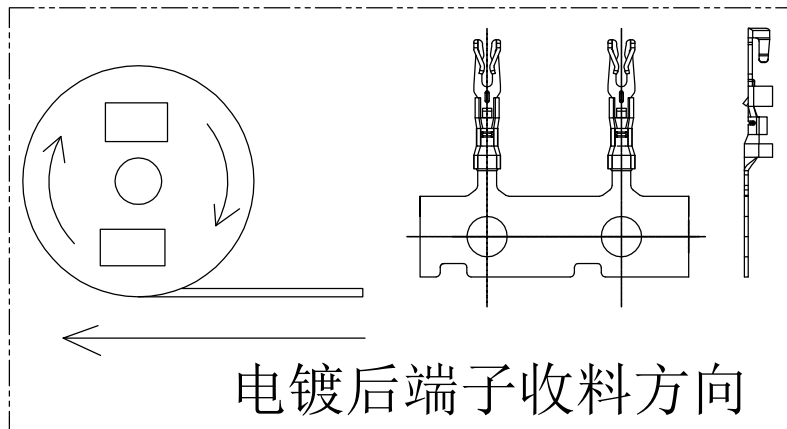

电镀后端子收料方向

REV.	REVISION RECORD	DATE		GENERAL TOLERANCES		SCALE: 1:1	NAME	DATE	PART.NO: A125ATFX-X	DWG.NO: ENDE05	 WanLian Technology Co., Ltd
A0	NEW RELEASE	21.01.13		LINEAR	ANGLES	APPROVED					
A1	Modification of dimensional tolerance	22.08.23	UNIT:mm	0.0±0.35	X'REF±6°	DESIGNER	TITLE: Pitch1.25mm 母端子 AWG # 24	REV: A2	SHEET: 1/1		
A2	增加挂钩高度尺寸	23.03.10		0.00±0.25	X'±3°	DRAWN					
			SIZE: A4	0.000±0.10	X'X' ±2°						