

The product using material and processing must conform to the "WI-PZ-001" HSF technical standard control requirements

RoHS

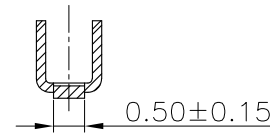
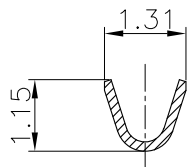
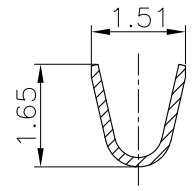
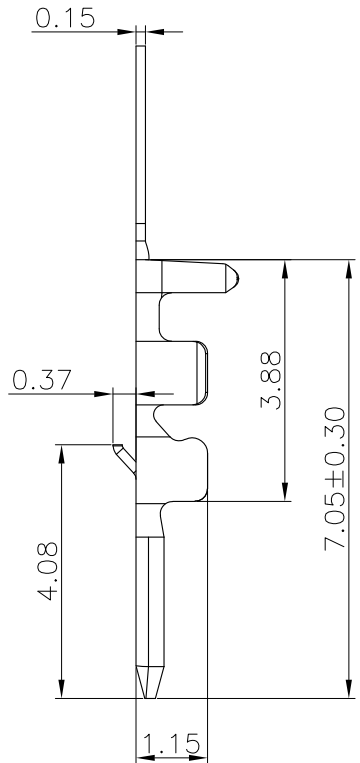
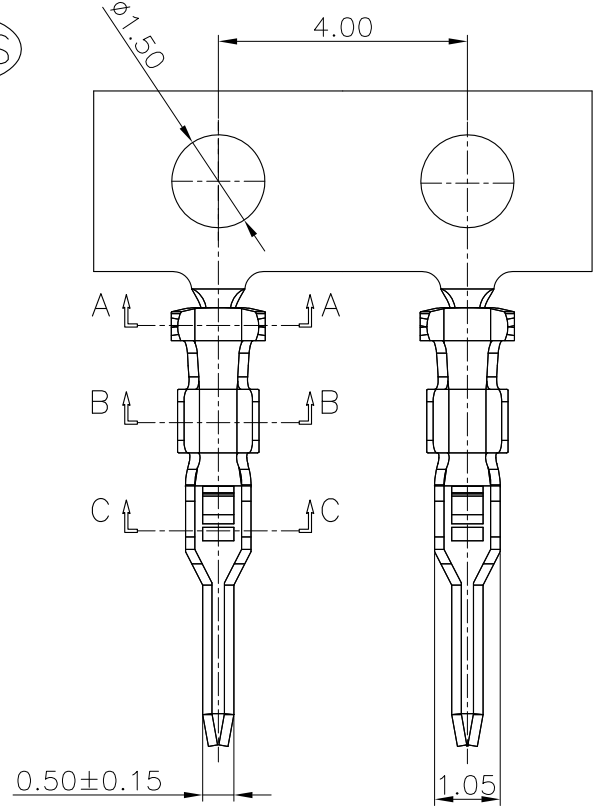

NOTE:
 1.MATERIAL SPECIFICATION:
 1-1.TERMINAL: PHOSPHOR BRONZE
 2.PLATING SPECIFICATION:
 2-1.TERMINAL:
 TIN/GOLD FLASH PLATED OVER ALL.
 3.ELECTRICAL PERFORMANCE:
 3-1.CURRENT RATING: 1A
 RATED VOLTAGE : 50V
 3-2.CONTACT RESISTANCE: 20 mΩ MAX
 3-3.INSULATION RESISTANCE: 500MΩ Min
 3-4.DIELECTRIC WITHSTANDING : 500V AC
 4.ENVIRONMENTAL PERFORMANCE:
 4-1.OPERATING TEMPERATURE: -25°C~+85°C.
 5.PACKAGE SPEC: REEL
 6.P/N:

A1501 T X M X-X
 SERIES NO: _____
 CONNECTOR: _____
 T-TERMINAL
 1-NO Mark
 2-With Mark
 MALE FEMALE:
 F-FEMALE
 M-MALE
 PLATING:
 A-ALL AU G/F
 C-BRIGHT TIN
 D-MATTE TIN
 METAL:
 P-PHOSPHOR BRONZE
 B-BRASS

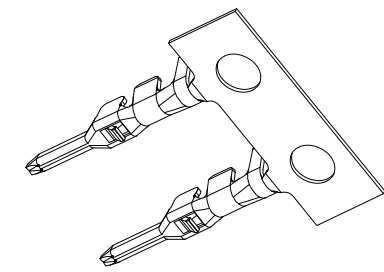

3D VIEW
1:2

REV.	REVISION RECORD	DATE		GENERAL TOLERANCES		SCALE: 1:1	NAME	DATE	PART.NO:	DWG.NO:	 WanLian Technology Co., Ltd
A0	NEW RELEASE	22.10.28		LINEAR	ANGLES	APPROVED	Wang_jr	22.10.28	A1501TXX-X	ENDE05	
			UNIT:mm	0.00 ± 0.25	$X^\circ \pm 3^\circ$	CHECK	XueZe_Ma	22.10.28	TITLE: Pitch1.50 mm ZM 公端子 AWG#26-#30		REV: A0
			SIZE: A4	0.000 ± 0.10	$X^\circ X' \pm 2^\circ$	DRAWN	LanXuan_Hou	22.10.28			SHEET: 1/1