

The product using material and processing must conform to the "WI-PZ-001"HSF technical standard control requirements

RoHS+HF

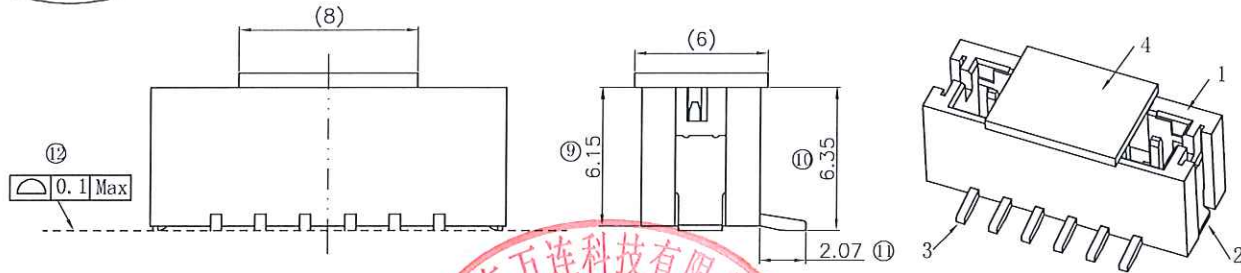

NOTE:

- MATERIAL SPECIFICATION:
 - HOUSING: LCP,UL94V-0
 - CONTACTS: BRASS
- PLATING SPECIFICATION:
 - CONTACTS: TIN/GOLD FLASH PLATED OVER ALL.
- ELECTRICAL PERFORMANCE:
 - CURRENT RATING: 2A
 - CONTACT RESISTANCE: 20 mΩ MAX
 - INSULATION RESISTANCE: 1000MΩ Min
 - DIELECTRIC WITHSTANDING : 800V
- ENVIRONMENTAL PERFORMANCE:
 - OPERATING TEMPERATURE: -40°C~+105°C.
- PACKAGE SPEC: TRAY
- P/N:

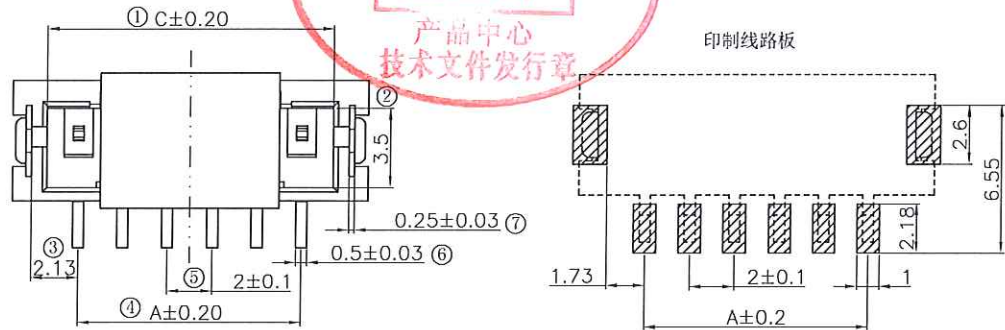

RECOMMENDED PCB Layout
DEFAULT TOLERANCES:±0.05(TOP VIEW)

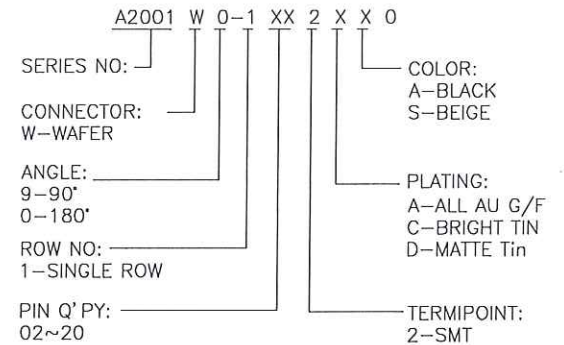

| NO | 物料名称 | 规格型号 | 数量(PCS) | 材质 | 镀涂 | 物料编码 |
|----|------|------|---------|-----|----|------|
| 1 | 底座 | 2.0 | 1 | LCP | 本色 | |
| 2 | 焊片 | 2.0 | 2 | 黄铜 | 锡 | |
| 3 | 插针 | 2.0 | 2~20 | 黄铜 | 锡 | |
| 4 | 盖板 | 2.0 | 1 | LCP | 本色 | |
| 品名 | | 连接器 | | 图号 | | |

| Circuits | Dimensions(mm) | | | Circuits | Dimensions(mm) | | |
|----------|----------------|-------|-------|----------|----------------|-------|-------|
| | A | B | C | | A | B | C |
| 02 | --- | 7.90 | 4.85 | 12 | 22.00 | 27.90 | 24.85 |
| 03 | 4.00 | 9.90 | 6.85 | 13 | 24.00 | 29.90 | 26.85 |
| 04 | 6.00 | 11.90 | 8.85 | 14 | 26.00 | 31.90 | 28.85 |
| 05 | 8.00 | 13.90 | 10.85 | 15 | 28.00 | 33.90 | 30.85 |
| 06 | 10.00 | 15.90 | 12.85 | 16 | 30.00 | 35.90 | 32.85 |
| 07 | 12.00 | 17.90 | 14.85 | 17 | 32.00 | 37.90 | 34.85 |
| 08 | 14.00 | 19.90 | 16.85 | 18 | 34.00 | 39.90 | 36.85 |
| 09 | 16.00 | 21.90 | 18.85 | 19 | 36.00 | 41.90 | 38.85 |
| 10 | 18.00 | 23.90 | 20.85 | 20 | 38.00 | 43.90 | 40.85 |
| 11 | 20.00 | 25.90 | 22.85 | | | | |

| REV. | REVISION RECORD | DATE | UNIT: mm | GENERAL TOLERANCES | | SCALE: 1:1 | NAME | DATE | PART. NO: | DWG. NO: | WanLian Technology Co., Ltd |
|------|---------------------|----------|----------|--------------------|-----------|------------|----------|-----------|----------------------|-----------------|-----------------------------|
| A0 | NEW RELEASE | 21.03.16 | | | LINEAR | ANGLES | APPROVED | 马学洋 | 2024.6.17 | A2001W0-1XX2XX0 | |
| A1 | PART NUMBER RENEWAL | | | 0.0±0.35 | X° REF±6° | DESIGNER | 梁林积 | 2024.6.17 | TITLE: | | REV: A1 |
| | | | SIZE: A4 | 0.00±0.25 | X° ±3° | DRAWN | 肖雨曦 | 2024.6.17 | WAFER PITCH 2.0mm 立贴 | | SHEET: 1/2 |

The product using material and processing must conform to the "WI-PZ-001"HSF technical standard control requirements

RoHS+HF

2.0-立贴系列

| | W | BO | F |
|-----|------------|------------|-----------|
| 2P | 16.00±0.30 | 8.35±0.10 | 7.50±0.10 |
| 3P | 24.00±0.30 | 10.35±0.10 | 11.5±0.10 |
| 4P | 24.00±0.30 | 12.35±0.10 | 11.5±0.10 |
| 5P | 24.00±0.30 | 14.35±0.10 | 11.5±0.10 |
| 6P | 24.00±0.30 | 16.35±0.10 | 11.5±0.10 |
| 7P | 32.00±0.30 | 18.35±0.10 | 14.2±0.10 |
| 8P | 32.00±0.30 | 20.35±0.10 | 14.2±0.10 |
| 9P | 44.00±0.30 | 22.35±0.10 | 20.2±0.10 |
| 10P | 44.00±0.30 | 24.35±0.10 | 20.2±0.10 |
| 11P | 44.00±0.30 | 26.35±0.10 | 20.2±0.10 |
| 12P | 44.00±0.30 | 28.35±0.10 | 20.2±0.10 |
| 13P | 44.00±0.30 | 30.35±0.10 | 20.2±0.10 |
| 14P | 44.00±0.30 | 32.35±0.10 | 20.2±0.10 |
| 15P | 56.00±0.30 | 34.35±0.10 | 26.2±0.10 |
| 16P | 56.00±0.30 | 36.35±0.10 | 26.2±0.10 |

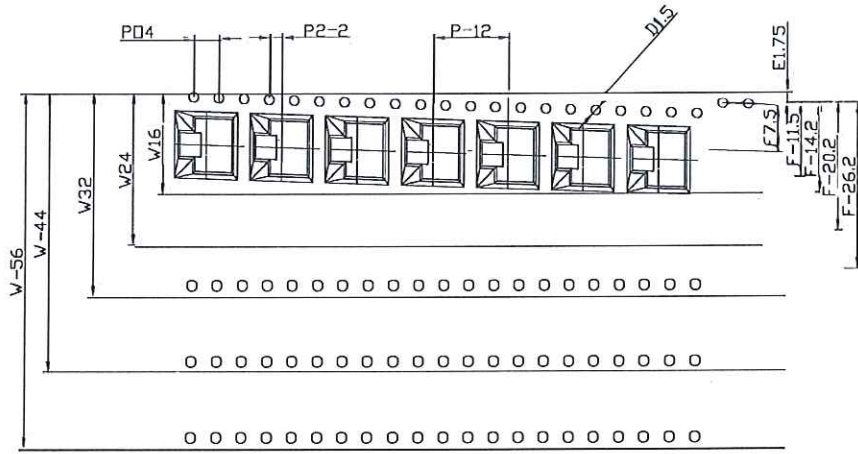

卷装示意图仅供参考

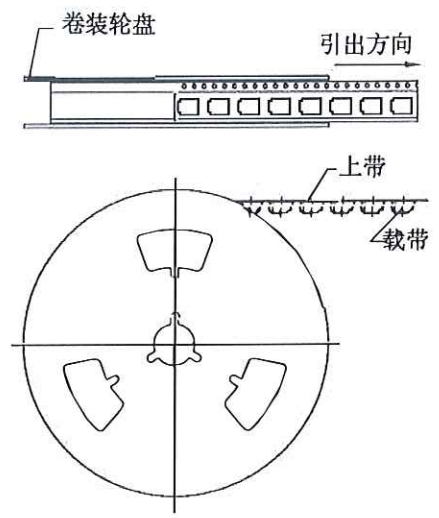

| 尺寸栏 | |
|-----|--|
| E | 1.75±0.10 |
| F | 7.5±0.10 |
| P2 | 2.00±0.10 |
| ∅D | 1.50 ^{+0.10} / _{-0.00} |
| Po | 4.00±0.10 |
| W | 16.00±0.30 |
| P | 12.0±0.10 |
| Ao | 8.25±0.10 |
| BO | 8.35±0.10 |
| KO | 7.65±0.10 |
| t | 0.35±0.05 |

| 生产参数 | |
|------|-------|
| 模数 | 93 # |
| 颗数 | 744 # |
| 卷轮 | 330mm |
| 包装数 | 700 # |

说明

- 10个边孔的累计公差不能超过±0.2mm.
- 材料规格: PS 白色料抗静电, 厚度 0.35mm.
- 13英寸卷轮卷装长度: 8.93米, 包装零件总颗数: 744颗, 前后各22PCS每盒实包颗数: 700颗
- 所有尺寸设计参照EIA-481-D.

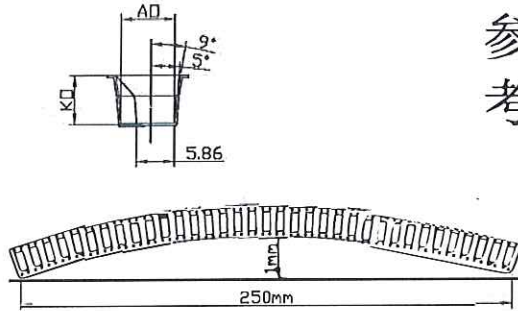

| 产品型号 | 盘装只数 | 整箱盘数 |
|----------|------|-------|
| 2.0-02P立 | 700 | 20R/箱 |
| 2.0-03P立 | 700 | 14R/箱 |
| 2.0-04P立 | 700 | 14R/箱 |
| 2.0-05P立 | 700 | 14R/箱 |
| 2.0-06P立 | 700 | 14R/箱 |
| 2.0-07P立 | 700 | 11R/箱 |
| 2.0-08P立 | 700 | 11R/箱 |
| 2.0-09P立 | 700 | 8R/箱 |
| 2.0-10P立 | 700 | 8R/箱 |
| 2.0-11P立 | 700 | 8R/箱 |
| 2.0-12P立 | 700 | 8R/箱 |
| 2.0-13P立 | 700 | 8R/箱 |
| 2.0-14P立 | 700 | 8R/箱 |
| 2.0-15P立 | 700 | 6R/箱 |
| 2.0-16P立 | 700 | 6R/箱 |

| REV. | REVISION RECORD | DATE | GENERAL TOLERANCES | SCALE: | NAME | DATE | PART. NO: | DWG. NO: |
|------|---------------------|----------|--------------------|----------|------|-----------|---------------------------|----------|
| A0 | NEW RELEASE | 21.03.16 | LINEAR | 1:1 | 马学洋 | 2024.6.17 | A2001W0-1XX2XX0 | ENDE05 |
| A1 | PART NUMBER RENEWAL | | 0.0±0.35 | APPROVED | 梁林积 | 2024.6.17 | TITLE: | |
| | | | 0.00±0.25 | DESIGNER | 肖雨曦 | 2024.6.17 | WAFER PITCH 2.0mm 立贴 包装规范 | |
| | | | 0.000±0.10 | DRAWN | | | | |

WanLian Technology Co., Ltd

REV: A1 SHEET: 2/2