

The product using material and processing must conform to the "WI-PZ-001"HSF technical standard control requirements

RoHS+HF

NOTE:

- MATERIAL SPECIFICATION:
  - HOUSING: PA66 UL94V-0
  - CONTACTS: BRASS
- PLATING SPECIFICATION:
  - CONTACTS: TIN/GOLD FLASH PLATED
- ELECTRICAL PERFORMANCE:
  - CURRENT RATING: 2A
  - CONTACT RESISTANCE: 20 mΩ MAX
  - INSULATION RESISTANCE: 1000MΩ Min
  - DIELECTRIC WITHSTANDING : 800V
- ENVIRONMENTAL PERFORMANCE:
  - OPERATING TEMPERATURE: -25°C~+85°C.
- PACKAGE SPEC: TRAY

6.P/N:



A2001 W 9 1-1 XX 1 X X X

SERIES NO: \_\_\_\_\_  
 CONNECTOR: \_\_\_\_\_  
 W-WAFER  
 ANGLE: \_\_\_\_\_  
 9-90°  
 TYPE: \_\_\_\_\_  
 1-TYPE 1  
 ROW NO: \_\_\_\_\_  
 1-SINGLE ROW  
 PIN Q'PY: \_\_\_\_\_  
 02~16

TYPE:  
 1-TYPE A  
 2-TYPE K

COLOR:  
 A-BLACK  
 K-WHITE

PLATING:  
 A-ALL AU G/F  
 C-BRIGHT TIN  
 D-MATTE TIN

TERMIPOINT:  
 1-DIP

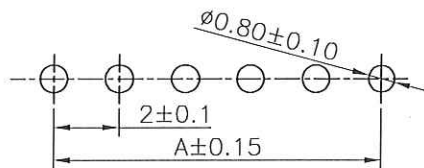
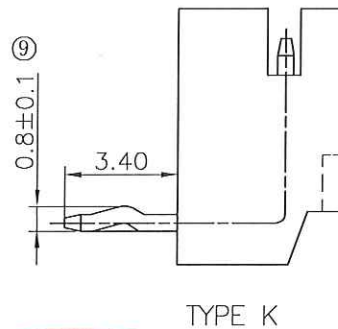
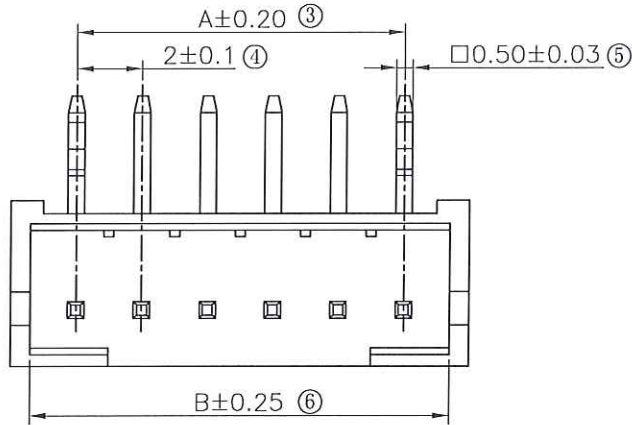
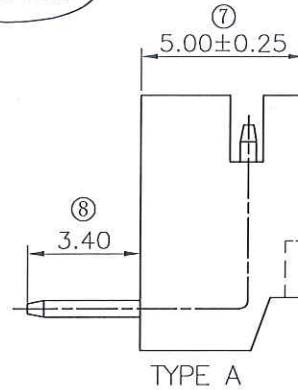
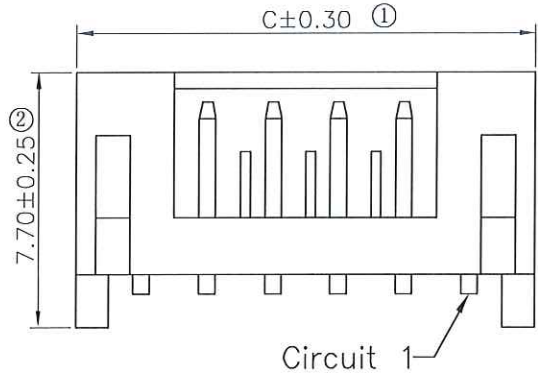

DEFAULT TOLERANCES:±0.10(TOP VIEW)



Circuit	Dimensions(mm)			Circuit	Dimensions(mm)		
	A	B	C		A	B	C
02	---	5.10	6.10	10	18.00	21.10	22.10
03	4.00	7.10	8.10	11	20.00	23.10	24.10
04	6.00	9.10	10.10	12	22.00	25.10	26.10
05	8.00	11.10	12.10	13	24.00	27.10	28.10
06	10.00	13.10	14.10	14	26.00	29.10	30.10
07	12.00	15.10	16.10	15	28.00	31.10	32.10
08	14.00	17.10	18.10	16	30.00	33.10	34.10
09	16.00	19.10	20.10				

REV.	REVISION RECORD	DATE	GENERAL TOLERANCES	SCALE:	NAME	DATE	PART.NO:	DWG.NO:
A0	NEW RELEASE	21.01.13	LINEAR	1:1			A2001W91-1XX1XXX	ENDE05
A1	PART NUMBER RENEWAL		ANGLES		马学洋	2024.6.17		
			0.0±0.35		梁林叔	2024.6.17	TITLE:	
			0.00±0.25		肖雨晴	2024.6.17	2.00mm Pitch 90°Wafer-DIP TYPE	
			0.00±0.25					REV: A1
			0.000±0.10					SHEET: 1/2



The product using material and processing must conform to the "WI-PZ-001"HSF technical standard control requirements

RoHS+HF

CARTON

POLY BAG



Poles	QUALITY	
	PCS/BAG	PCS/CARTON
2	2000	72000
3	2000	72000
4	2000	72000
5	2000	72000
6	2000	72000
7	2000	72000
8	1000	36000
9	1000	36000
10	1000	36000
11	1000	36000
12	1000	36000
13	1000	36000
14	1000	36000
15	1000	36000
16	1000	36000

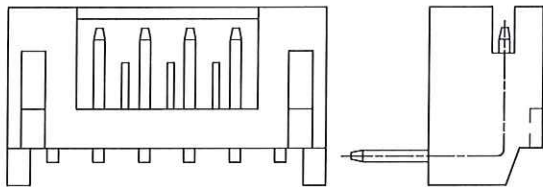

REV.	REVISION RECORD	DATE		GENERAL TOLERANCES		SCALE: 1:1	NAME	DATE	PART.NO: A2001W91-1XX1XXX	DWG.NO: ENDE05	 WanLian Technology Co., Ltd
A0	NEW RELEASE	21.01.13		LINEAR	ANGLES	APPROVED	梁林权	2024.6.17			
A1	PART NUMBER RENEWAL		UNIT:mm	0.0±0.35	X'REF±6'	DESIGNER	梁林权	2024.6.17	TITLE: 2.00mm Pitch 90°Wafer-DIP TYPE	REV: A1	SHEET: 2/2
			SIZE: A4	0.00±0.25	X'±3'	DRAWN	肖雨曦	2024.6.17			