

The product using material and processing must conform to the "WI-PZ-001"HSF technical standard control requirements

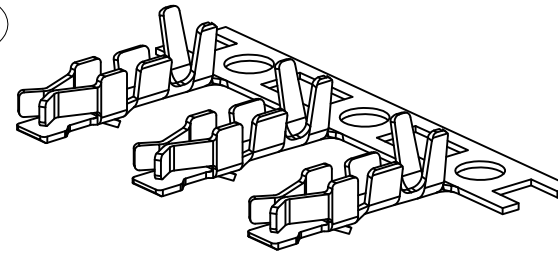

3D VIEW

NOTE:
 1.MATERIAL SPECIFICATION:
 1-1.TREMINAL:PHOSPHOR BRONZE
 AWG #22 -#28
 2.PLATING SPECIFICATION:
 2-1.TREMINAL:
 BRIGHT TIN PLATED ON CONTACT AREA.
 3.MECHANICAL PERFORMANCE:
 3-1.RETENTIVITY FORCE: 1.2KGF/PIN MIN
 3-3.DURABILITY: 30 CYCLES.
 4.ELECTRICAL PERFORMANCE:
 4-1. RATED CURRENT : 3A AC,DC
 RATED VOLTAGE : 250V AC/DC
 4-2.INSULATION RESISTANCE: 1000MΩ MIN
 CONTACT RESISTANCE : 20MΩ(MAX.)
 4-3.WITHSTANDING VOLTAGE: 800V AC
 5.ENVIRONMENTAL PERFORMANCE:
 OPERATING TEMPERATURE: -25°C~+85°C.
 6.PACKAGE SPEC:PAPER PLATE
 7.P/N: A2002 T F X-X

SERIES NO: A2002 T F X-X
 CONNECTOR: T-TERMINAL
 MALE FEMALE: F-FEMALE M-MALE
 PLATING:
 1-G/F
 A-ALL AU G/F
 C-BRIGHE TIN
 D-MATTE TIN
 METAL:
 P-PHOSPHOR BRONZE
 B-BRASS

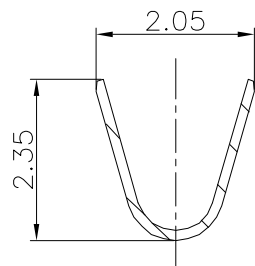
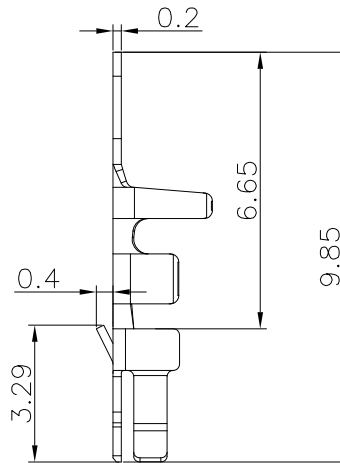
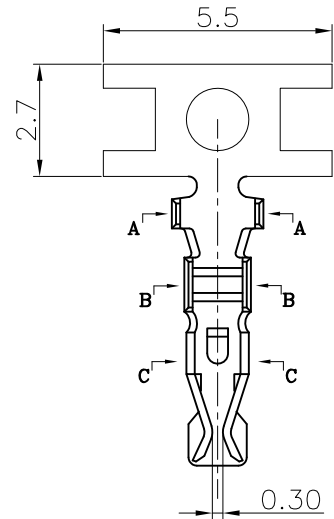

SECTION:A-A

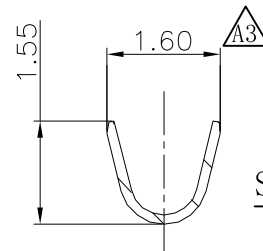

SECTION:B-B

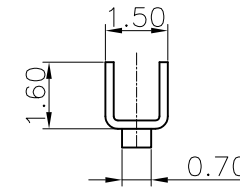

SECTION:C-C

REV.	REVISION RECORD	DATE	UNIT:mm	GENERAL TOLERANCES		SCALE: 1:1	NAME	DATE	PART.NO:	DWG.NO:		
A0	NEW RELEASE	21.01.13		LINEAR	ANGLES	APPROVED	Wang_jr	23.9.13	A2002TFX-X	ENDE05		
A1	Modify the size	22.05.13	SIZE: A4	0.0±0.35	X°REF±6°	DESIGNER	Han_Gao	23.9.13	TITLE: PITCH2.00mm 180° PA TERMINAL AWG		REV: A3	SHEET: 1/1
A2	依实物变更图纸	22.10.18		0.00±0.25	X°±3°	DRAWN	Zijun_Huang	23.9.13				
A3	依实物变更图纸	23.9.13		0.000±0.10	X°X' ±2°							