

The product using material and processing must conform to the "WL-PZ-001" HSF technical standard control requirements

RoHS+HF

- NOTE:
- MATERIAL SPECIFICATION:
 - HOUSING: PA66,UL94V-0
 - CONTACTS: BRASS
 - PLATING SPECIFICATION:
 - CONTACTS: TIN/GOLD FLASH PLATED OVER ALL.
 - MECHANICAL PERFORMANCE:
 - RETENTIVITY FORCE: 1.5KGF/Pin Min
 - DURABILITY: 50 CYCLES.
 - ELECTRICAL PERFORMANCE:
 - CURRENT RATING: 3A AC/DC
RATED VOLTAGE : 250V AC/DC
 - CONTACT RESISTANCE: 10 mΩ MAX
 - INSULATION RESISTANCE: 1000MΩ Min
 - DIELECTRIC WITHSTANDING : 800V
 - ENVIRONMENTAL PERFORMANCE:
 - OPERATING TEMPERATURE: -25°C~+85°C.
 - PACKAGE SPEC: PE BAG
 - P/N:

A2006 W 9 2-2 XX 1 X X X
 SERIES NO: J
 CONNECTOR: W-WAFER
 ANGLE: 9-90°
 TYPE: 2-TYPE 2
 ROW NO: 2-DOUBLE ROW
 PIN Q'PY: 04~40
 WATER CODE: 0-N/A
 COLOR: A-BLACK, K-WHITE
 PLATING: A-ALL AU G/F, C-BRIGHT TIN, D-MATTE TIN
 TERMIPOINT: 1-DIP

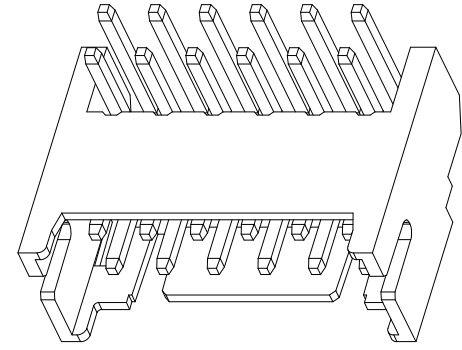
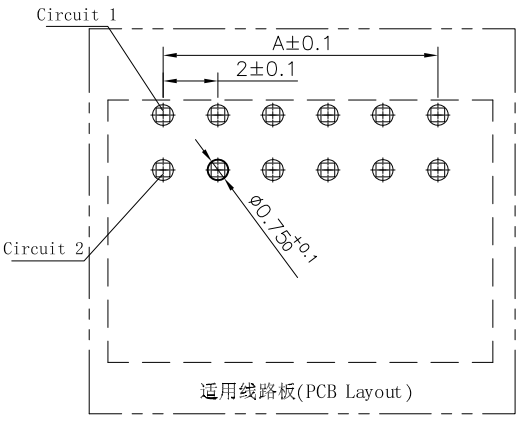
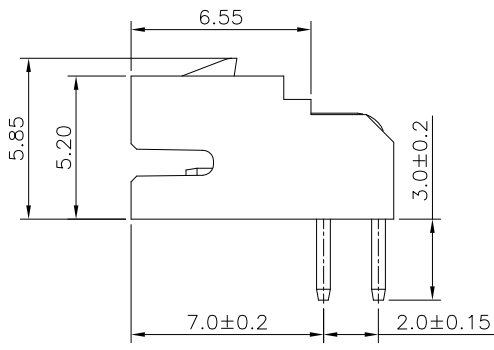
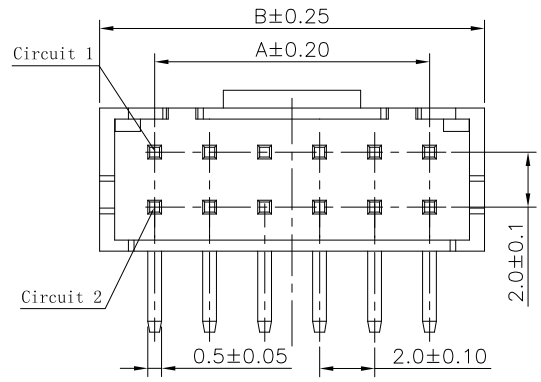
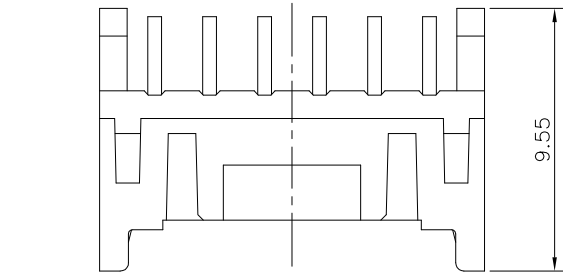

Circuit	Dimensions(mm)		Circuit	Dimensions(mm)	
	A	B		A	B
2*02	---	6.00	2*12	22.00	26.00
2*03	4.00	8.00	2*13	24.00	28.00
2*04	6.00	10.00	2*14	26.00	30.00
2*05	8.00	12.00	2*15	28.00	32.00
2*06	10.00	14.00	2*16	30.00	34.00
2*07	12.00	16.00	2*17	32.00	36.00
2*08	14.00	18.00	2*18	34.00	38.00
2*09	16.00	20.00	2*19	36.00	40.00
2*10	18.00	22.00	2*20	38.00	42.00
2*11	20.00	24.00			

REV.	REVISION RECORD	DATE		GENERAL TOLERANCES		SCALE: 1:1	NAME	DATE	PART.NO:	DWG.NO:				
A0	NEW RELEASE	22.10.28		LINEAR	ANGLES							APPROVED	Wang_jr	23.9.8
A1	PART NUMBER RENEWAL	23.9.8		0.00±0.25	X°±3°	DESIGNER	Han_Gao	23.9.8	TITLE:	Pitch 2.0mm 90°PHD双排卧插带扣带定位墙 Wafer无卤	WanLian Technology Co., Ltd REV: A1 SHEET: 1/1			
				0.00±0.35	X°REF±6°							DRAWN	LanXuan_Hou	23.9.8
				UNIT:mm	X°±3°									
			SIZE: A4	0.000±0.10	X°X' ±2°									