

The product using material and processing must conform to the "WI-PZ-001"HSF technical standard control requirements

RoHS

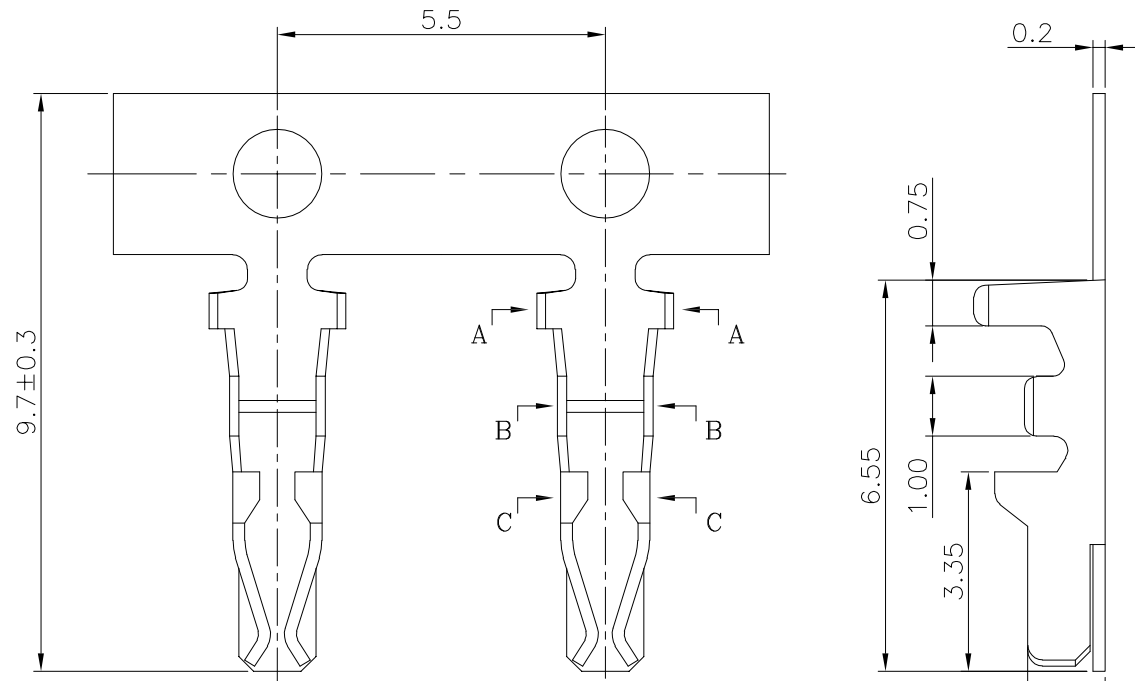

- NOTE:
- MATERIAL SPECIFICATION:  
1-1.TERMINAL: PHOSPHOR BRONZE
  - PLATING SPECIFICATION:  
2-1.TERMINAL:  
TIN/GOLD FLASH PLATED OVER ALL.
  - ELECTRICAL PERFORMANCE:  
3-1.CURRENT RATING: 2A AC/DC  
3-2.CONTACT RESISTANCE: 20 mΩ MAX  
3-3.INSULATION RESISTANCE: 1000MΩ Min  
3-4.DIELECTRIC WITHSTANDING : 1000V
  - ENVIRONMENTAL PERFORMANCE:  
4-1.OPERATING TEMPERATURE: -25°C~+85°C.
  - PACKAGE SPEC : REEL
  - P/N:

SERIES NO: A2008 T 2 F X-X

CONNECTOR: T-TERMINAL

TYPE CODE

MALE FEMALE: F-FEMALE M-MALE

PLATING:  
A-ALL AU G/F  
C-BRIGHT TIN  
D-MATTE TIN

METAL:  
P-PHOSPHOR BRONZE  
B-BRASS

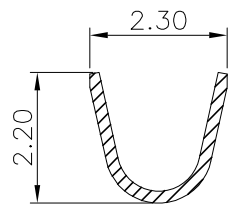

SECTION:A-A

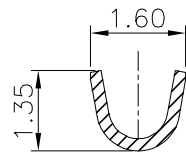

SECTION:B-B

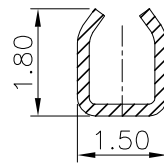

SECTION:C-C

REV.	REVISION RECORD	DATE		GENERAL TOLERANCES		SCALE: 1:1	NAME	DATE	PART.NO:	DWG.NO:	 WanLian Technology Co., Ltd
AO	NEW RELEASE	22.10.28		LINEAR	ANGLES	APPROVED	Wang_jr	22.10.28	A2008T2FX-X	ENDE05	
			0.0±0.35	X'REF±6'	DESIGNER	Han_Gao	22.10.28	TITLE:			
			UNIT:mm	X'±3'	DRAWN	LanXuan_Hou	22.10.28	Pitch2.00mm HY TerFinal AWG #28 -#22			
			SIZE: A4	0.000±0.10	X'X' ±2'					REV: A0	SHEET: 1/1