

The product using material and processing must conform to the "WI-PZ-001" HSF technical standard control requirements

RoHS

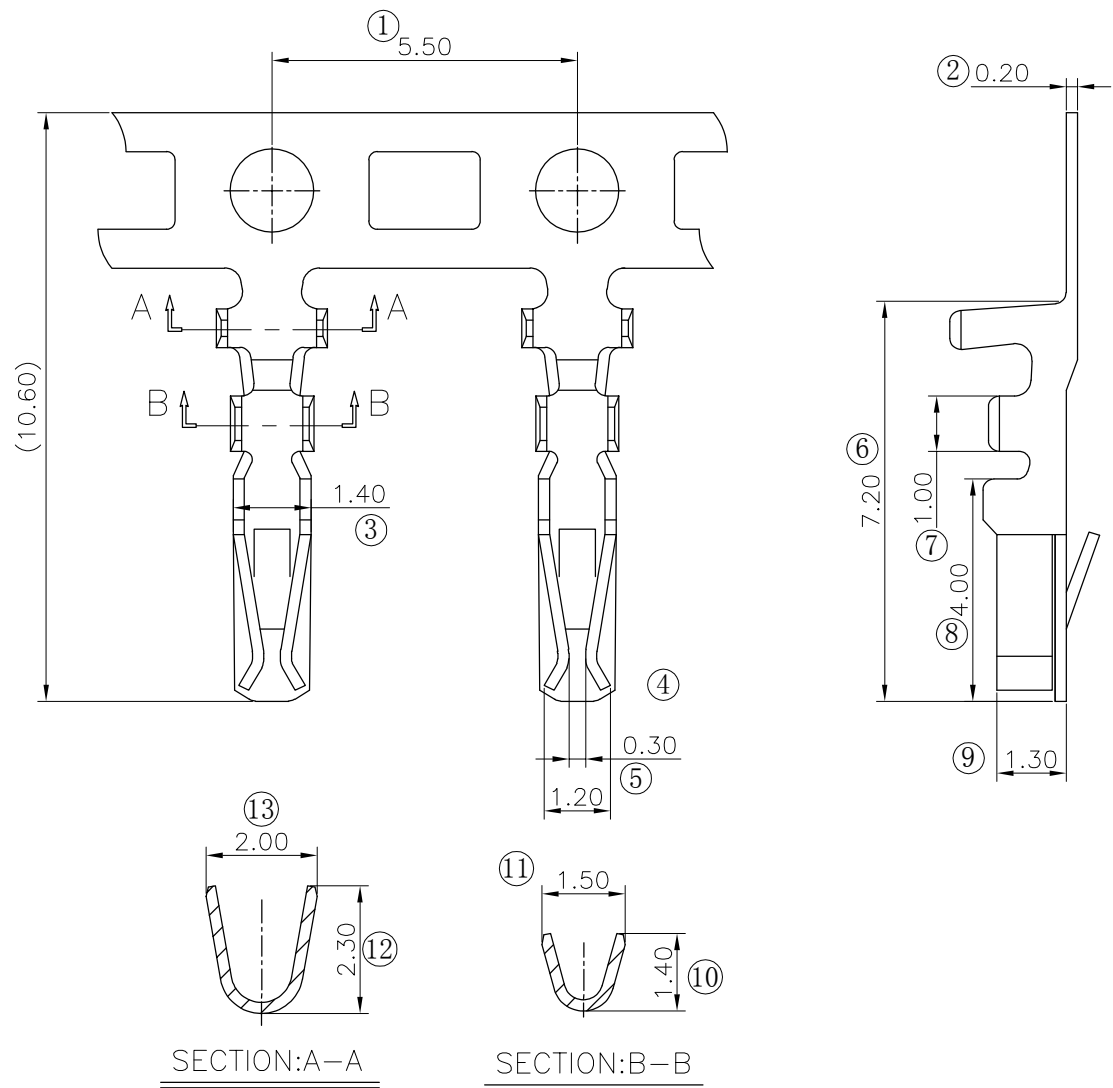

NOTE:
 1.MATERIAL SPECIFICATION:
 1-1.TERMINAL: PHOSPHOR BRONZE
 2.PLATING SPECIFICATION:
 2-1.TERMINAL:
 TIN/GOLD FLASH PLATED OVER ALL.
 3.ELECTRICAL PERFORMANCE:
 3-1.CURRENT RATING: 3.0A
 3-2.CONTACT RESISTANCE: 20 mΩ MAX
 3-3.INSULATION RESISTANCE: 1000MΩ Min
 3-4.DIELECTRIC WITHSTANDING : 1000V AC
 4.ENVIRONMENTAL PERFORMANCE:
 4-1.OPERATING TEMPERATURE: -25°C~+85°C.
 5.WIRE RANGE: AWG24#-28#
 6.PACKAGE SPEC : PE BAG
 7.P/N:

A2009 T F X-X
 SERIES NO: _____ PLATING:
 C-BRIGHT TIN
 CONNECTOR: _____
 T-TERMINAL
 MALE FEMALE: _____ METAL:
 F-FEMALE P-PHOSPHOR BRONZE

REV.	REVISION RECORD	DATE		GENERAL TOLERANCES		SCALE: 1:1	NAME	DATE	PART.NO:	DWG.NO:	 WanLian Technology Co., Ltd
A0	NEW RELEASE	22.03.19		LINEAR	ANGLES	APPROVED	Wang_jr	22.03.19	A2009TFX-X	ENDE05	
			UNIT:mm	0.00±0.25	X°±3'	CHECK	XueZe_Ma	22.03.19	TITLE:		REV: A0 SHEET: 1/2
			SIZE: A4	0.000±0.10	X°X' ±2'	DRAWN	LanXuan_Hou	22.03.19	Pitch2.00mm FEMALE Terminal AWG #24 -#28		

The product using material and processing must conform to the "WI-PZ-001"HSF technical standard control requirements

RoHS

端子卡点朝外，开口朝内

备注:

1. 纸箱装箱以不超过装箱线为准，空余位置用塑料泡沫及保尼龙填充；

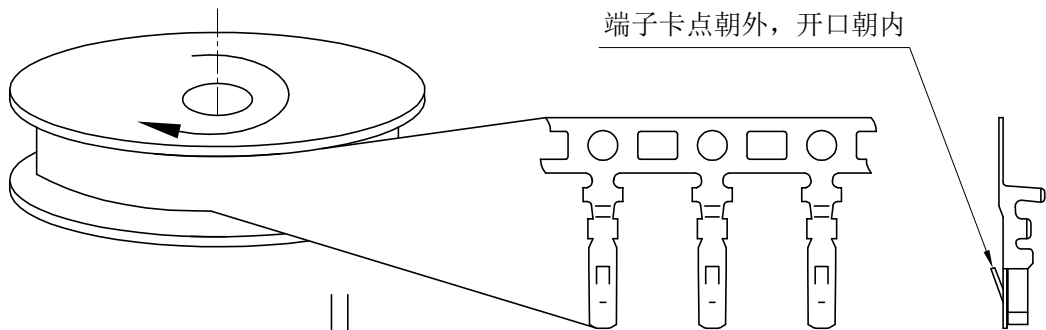

PCS/REEL	REEL/CARTON	LARGE SUM(PCS)
14000	29	406000

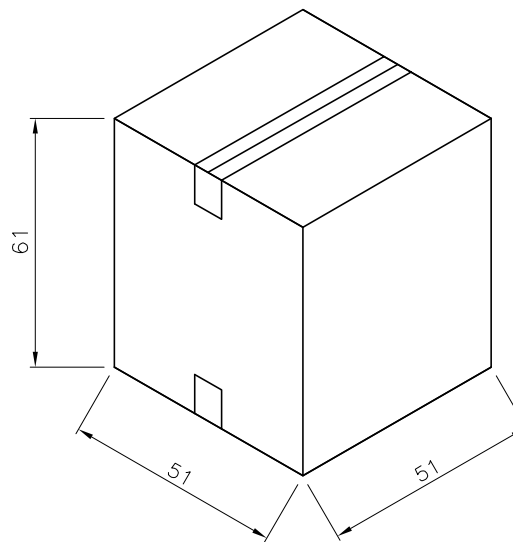
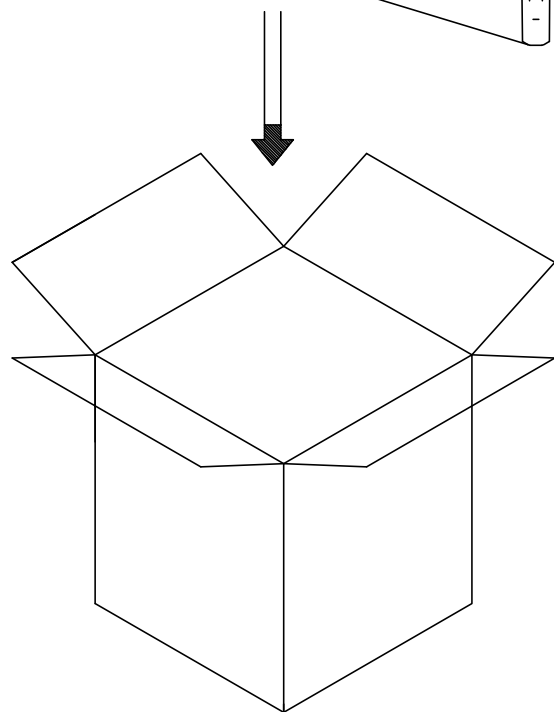

REV.	REVISION RECORD	DATE		GENERAL TOLERANCES		SCALE: 1:1	NAME	DATE	PART.NO:	DWG.NO:	
AO	NEW RELEASE	22.03.19		LINEAR	ANGLES	APPROVED	Wang_jr	22.03.19	A2009TFX-X	ENDE05	
			0.0±0.35	X'REF±6°	CHECK	XueZe_Ma	22.03.19	TITLE:		REV: A0 SHEET: 2/2	
			0.00±0.25	X'±3°	DRAWN	LanXuan_Hou	22.03.19	Pitch2.00mm FEMALE Terminal AWG #24 -#28			
			UNIT:mm	X'±3°							
			SIZE: A4	X'X' ±2°							

WanLian Technology Co., Ltd