

The product using material and processing must conform to the "WI-PZ-001" HSF technical standard control requirements



- NOTE:
- MATERIAL SPECIFICATION:
 - HOUSING: PA6T, UL94V-0
 - CONTACTS: BRASS
 - PLATING SPECIFICATION:
 - CONTACTS: TIN/GOLD FLASH PLATED OVER ALL.
 - ELECTRICAL PERFORMANCE:
 - CURRENT RATING: 3A AC/DC
 - CONTACT RESISTANCE: 20 mΩ MAX
 - INSULATION RESISTANCE: 1000MΩ Min
 - DIELECTRIC WITHSTANDING: 1000V
 - ENVIRONMENTAL PERFORMANCE:
 - OPERATING TEMPERATURE: -25°C~+85°C.
 - PACKAGE SPEC: PE BAG
 - P/N:

A2009 W 9 2-2 XX 1 X X X

SERIES NO: A2009
 CONNECTOR: W-WAFER
 ANGLE: 9-90°
 TYPE: 2-TYPE 2
 ROW NO: 2-DOUBLE ROW
 PIN Q'PY: 04~30

WATER CODE: 0-N/A
 COLOR: M-BEIGE
 PLATING: C-BRIGHT TIN
 TERMIPOINT: 1-DIP

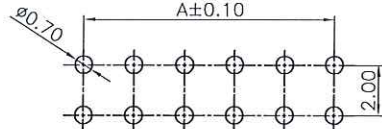
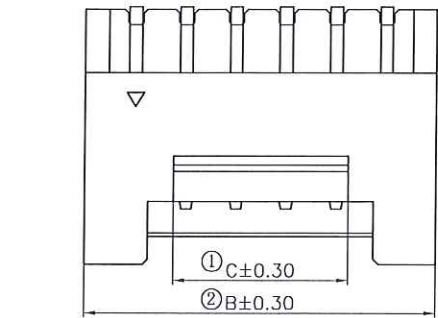

RECOMMENDED PCB LAYOUT
 (GENERAL TOLERANCE: ±0.05)

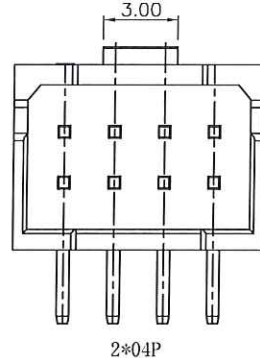
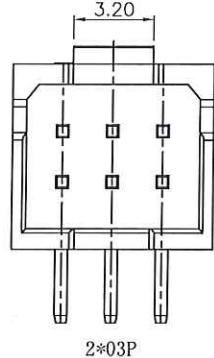
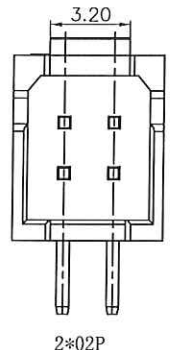
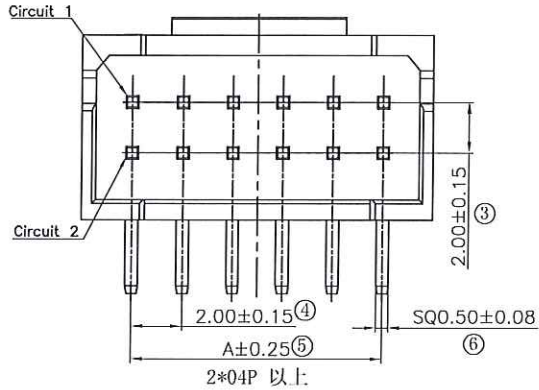
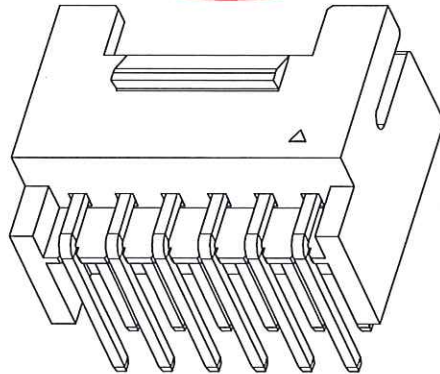
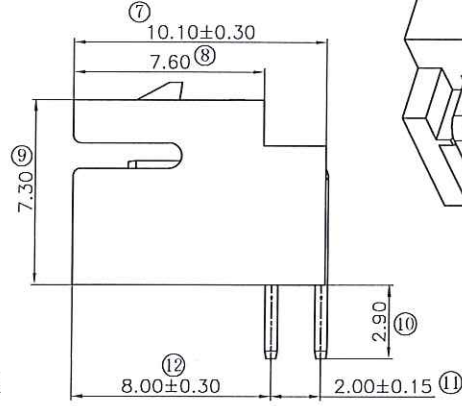

Circuit	Dimensions(mm)			Circuit	Dimensions(mm)		
	A	B	C		A	B	C
2*02	---	6.00	3.20	2*09	16.00	20.00	13.00
2*03	4.00	8.00	3.20	2*10	18.00	22.00	15.00
2*04	6.00	10.00	3.00	2*11	20.00	24.00	17.00
2*05	8.00	12.00	5.00	2*12	22.00	26.00	19.00
2*06	10.00	14.00	7.00	2*13	24.00	28.00	21.00
2*07	12.00	16.00	9.00	2*14	26.00	30.00	23.00
2*08	14.00	18.00	11.00	2*15	28.00	32.00	25.00

REV.	REVISION RECORD	DATE	GENERAL TOLERANCES		SCALE: 1:1	NAME	DATE	PART.NO:	DWG.NO:	 WanLian Technology Co., Ltd	
AO	NEW RELEASE		LINEAR	ANGLES	APPROVED	8/8/24	2024.6.7	A2009W92-2XX1XXX	ENDE05		
			0.0±0.35	X'REF±6'	CHECK	梁林权	2024.6.7	TITLE:			
			UNIT:mm	0.00±0.25	X'±3'	DRAWN	苗雨薇	2024.6.7	Pitch 2.0mm 90° 双排 DIP Wafer		
			SIZE: A4	0.000±0.10	X'X'±2'					REV: A0	SHEET: 1/2

The product using material and processing must conform to the "WI-PZ-001"HSF technical standard control requirements

RoHS

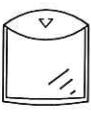
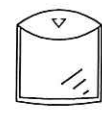
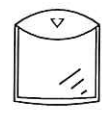
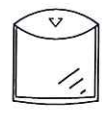
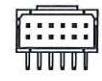

PE袋 1 Pcs
数量 :每袋=2~0.3Kpcs

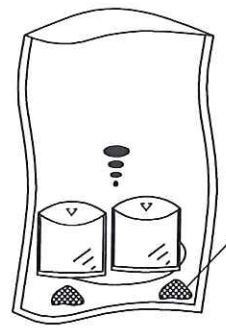

干燥剂

PE防水袋 1 Pcs

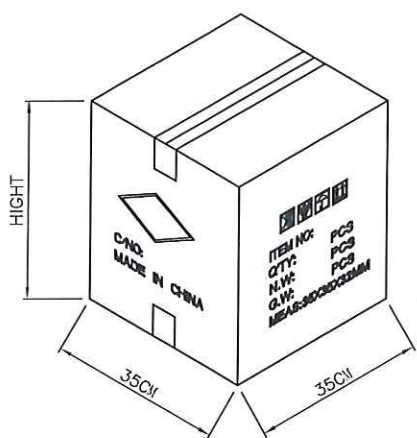
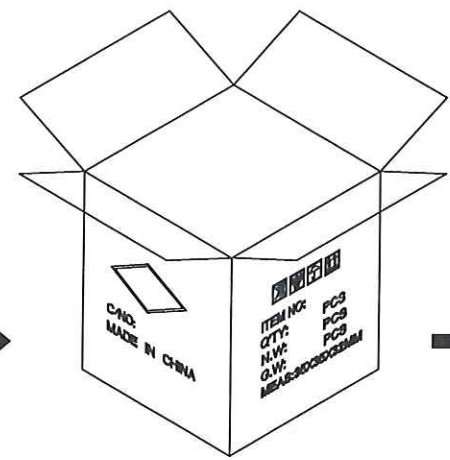

备注:

1. 纸箱装箱以不超过装箱线为准, 空余位置用塑料泡沫及保尼龙填充;
2. 纸箱分小、中、标准型3种规格型号: 装箱为整箱(左下包装量)采用标准型纸箱包装, 未达到整箱数量以产品量适当采用小型或中型纸箱包装;
3. 因生产Pin位未齐全, 每袋与整箱包装数量仅供参考, 具体包装数量以实际出货为准, 或批量出货更新后为准;



纸箱型号 Carton Type	小型 Small Size	中型 Medium	标准型 Standard	大型 Large
长度 Long (CM)	35	35	35	46
宽度 Wide (CM)	35	35	35	46
高度 Hight (CM)	7.5	15	32	46

CKT	PCS/BAG	CKT	PCS/BAG
2	2000	10	500
3	2000	11	500
4	2000	12	500
5	1000	13	500
6	1000	14	300
7	1000	15	300
8	1000	16	300
9	500		

REV.	REVISION RECORD	DATE	UNIT:mm	GENERAL TOLERANCES		SCALE: 1:1	NAME	DATE	PART.NO:	DWG.NO:	REV: A0	SHEET: 2/2
A0	NEW RELEASE			SIZE: A4	LINEAR	ANGLES	APPROVED	梁林权	2024.6.7	A2009W92-2XX1XXX		
				0.0±0.35	X'REF±6'	CHECK	梁林权	2024.6.7	TITLE: Pitch 2.0mm 90° 双排 DIP Wafer			
				0.00±0.25	X'±3'	DRAWN	肖雨晴	2024.6.7				
				0.000±0.10	X'X' ±2'							

