

The product using material and processing must conform to the "WI-PZ-001"HSF technical standard control requirements

RoHS

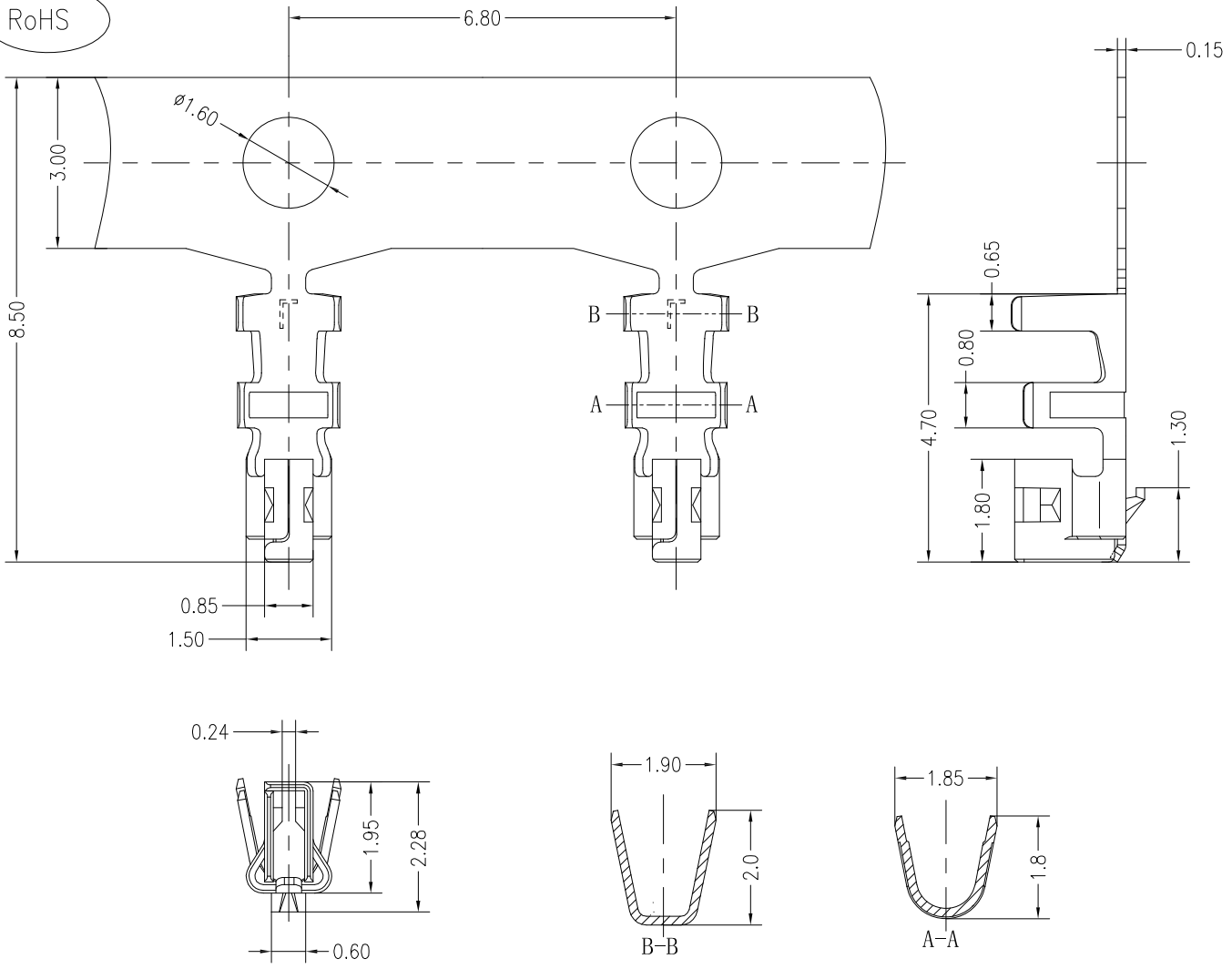

NOTE:
 1.MATERIAL SPECIFICATION:
 1-1.CONTACTS: PHOSPHOR BRONZE
 2.PLATING SPECIFICATION:
 2-1.CONTACTS:
 TIN/GOLD FLASH PLATED OVER ALL.
 3.MECHANICAL PERFORMANCE:
 3-1.DURABILITY: 50 CYCLES.
 4.ELECTRICAL PERFORMANCE:
 4-1.CURRENT RATING: 3A
 RATED VOLTAGE : 125V AC/DC
 4-2.CONTACT RESISTANCE: 10 mΩ MAX
 4-3.INSULATION RESISTANCE: 1000 MΩ Min
 4-4.DIELECTRIC WITHSTANDING : 500V
 5.ENVIRONMENTAL PERFORMANCE:
 5-1.OPERATING TEMPERATURE: -40°C~+105°C.
 6.PACKAGE SPEC: REEL PACKING
 7.P/N: A2023 T F X-X
 SERIES NO: _____ PLATING:
 A-ALL AU G/F
 C-BRIGHE TIN
 D-MATTE TIN
 CONNECTOR: _____
 T-TERMINAL
 METAL:
 P-PHOSPHOR BRONZE
 B-BRASS
 MALE FEMALE: _____
 F-FEMALE

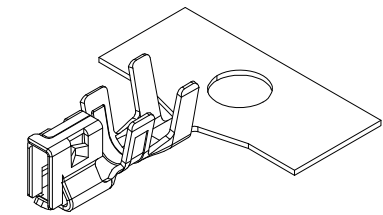

REV.	REVISION RECORD	DATE		GENERAL TOLERANCES		SCALE: 1:1	NAME	DATE	PART.NO:	DWG.NO:	 WanLian Teconology Co., Ltd
AO	NEW RELEASE	21.10.12		LINEAR	ANGLES	APPROVED	Wang_jr	21.10.12	A2023TFX-X	ENDE05	
			UNIT: mm	0.00±0.25	X'±3'	DESIGNER	Han_Gao	21.10.12	TITLE:		REV: AO SHEET: 1/1
			SIZE: A4	0.000±0.10	X'X' ±2'	DRAWN	Zijun_Huang	21.10.12	Pitch2.00mm Wire To Board Crimp Terminal AWG#22~#26		