

The product using material and processing must conform to the "WI-PZ-001"HSF technical standard control requirements

RoHS+HF

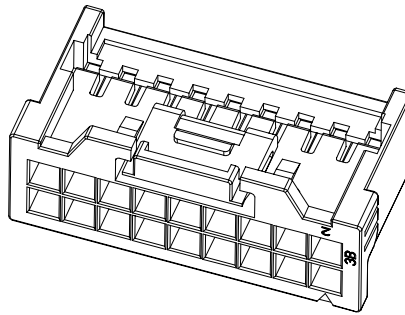
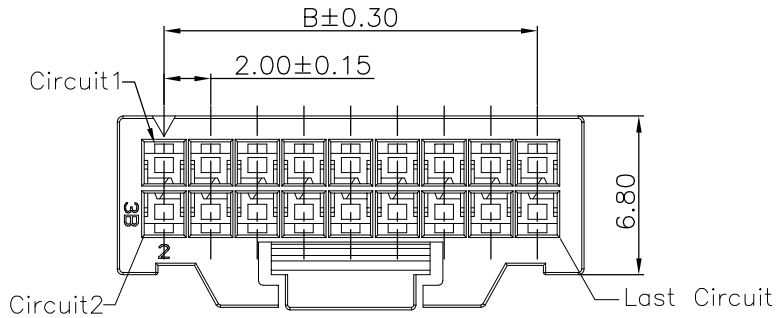

NOTE:

- 1.MATERIAL SPECIFICATION:
1-1.HOUSING: PA66,UL94V-0
- 2.ELECTRICAL PERFORMANCE:
2-1.INSULATION RESISTANCE: 1000MΩ Min
2-2.DIELECTRIC WITHSTANDING : 1000V
- 3.ENVIRONMENTAL PERFORMANCE:
3-1.OPERATING TEMPERATURE: -25°C~+85°C.
- 4.PACKAGE SPEC: PE BAG
- 5.P/N:

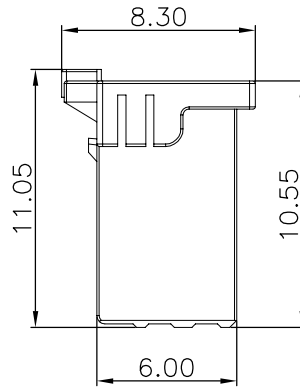
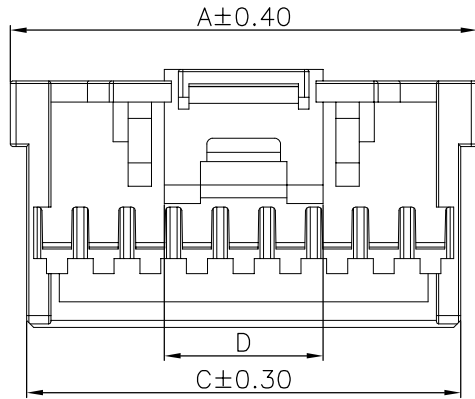

SERIES NO: A2036 H M-2 XX X 0
 COLOR:
 A-BLACK
 S-NATURE
 CONNECTOR:
 H-HOUSING
 MALE FEMALE:
 M-MALE
 PIN Q'PY:
 04~40
 ROW NO:
 2-DOUBLE ROW

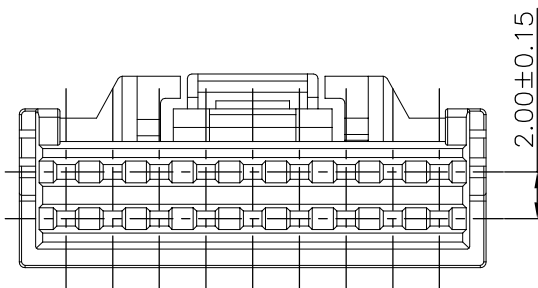

Circuit	A	B	C	D	Circuit	A	B	C	D
2*02	6.0	2.0	4.6	2.2	2*12	26.0	22.0	24.6	6.8
2*03	8.0	4.0	6.6	2.2	2*13	28.0	24.0	26.6	6.8
2*04	10.0	6.0	8.6	3.1	2*14	30.0	26.0	28.6	6.8
2*05	12.0	8.0	10.6	5.1	2*15	32.0	28.0	30.6	6.8
2*06	14.0	10.0	12.6	6.8	2*16	34.0	30.0	32.6	6.8
2*07	16.0	12.0	14.6	6.8	2*17	36.0	32.0	34.6	6.8
2*08	18.0	14.0	16.6	6.8	2*18	38.0	34.0	36.6	6.8
2*09	20.0	16.0	18.6	6.8	2*19	40.0	36.0	38.6	6.8
2*10	22.0	18.0	20.6	6.8	2*20	42.0	38.0	40.6	6.8
2*11	24.0	20.0	22.6	6.8					

REV.	REVISION RECORD	DATE	GENERAL TOLERANCES		SCALE:	NAME	DATE	PART.NO:	DWG.NO:	 WanLian Technology Co., Ltd REV: A0 SHEET: 1/3
AO	NEW RELEASE	21.10.12	LINEAR	ANGLES	1:1				ENDE05	
			0.0±0.35	X'REF±6°	APPROVED	Wang_jr	21.10.12	TITLE:		
			UNIT: mm	0.00±0.25	X'±3°	DESIGNER	Han_Gao	Pitch2.00mm MX双排带扣Housing 无logo		
			SIZE: A4	0.000±0.10	X'X' ±2'	DRAWN	Zijun_Huang			

The product using material and processing must conform to the "WI-PZ-001"HSF technical standard control requirements

RoHS+HF

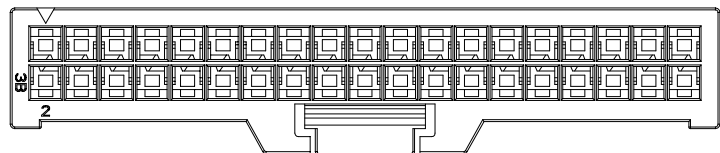

2*19P

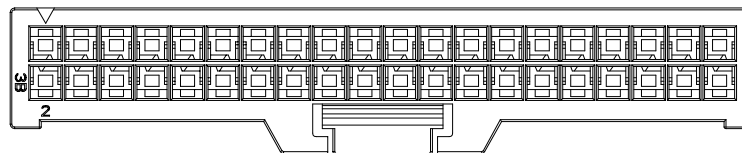

2*20P

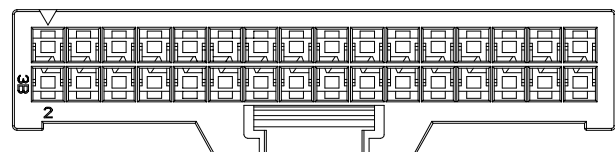

2*16P

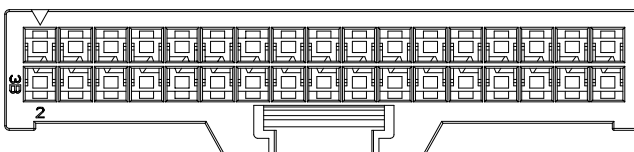

2*17P

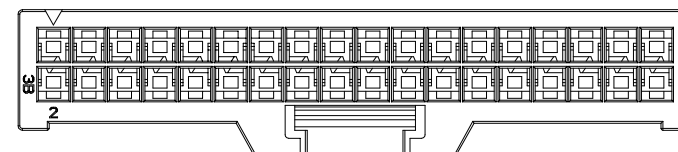

2*18P

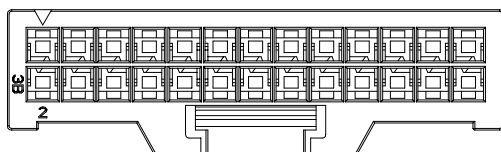

2*13P

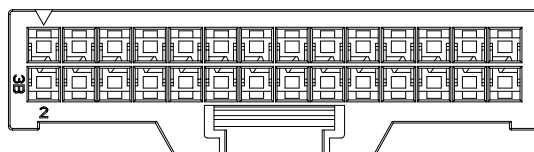

2*14P

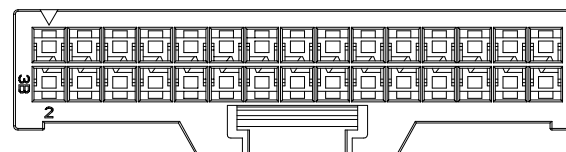

2*15P

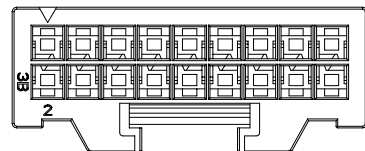

2*09P

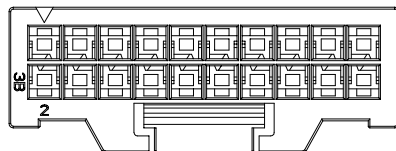

2*10P

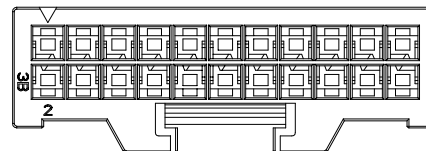

2*11P

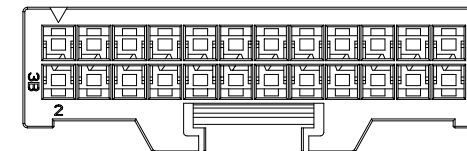

2*12P

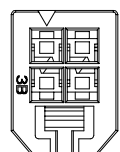

2*02P

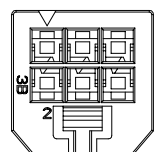

2*03P

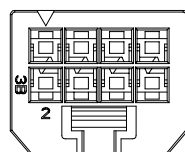

2*04P

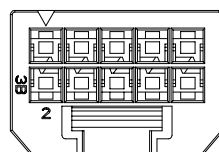

2*05P

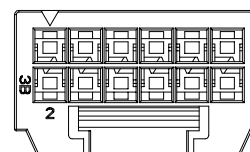

2*06P

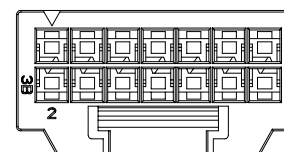

2*07P

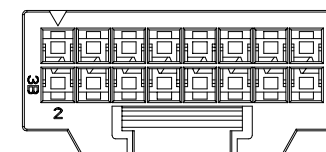

2*08P

REV.	REVISION RECORD	DATE		GENERAL TOLERANCES		SCALE: 1:1	NAME	DATE	PART.NO: A2036HM-2XXX0	DWG.NO: ENDE05	 WanLian Technology Co., Ltd
AO	NEW RELEASE	21.10.12		LINEAR	ANGLES	APPROVED	Wang_jr	21.10.12			
			UNIT: mm	0.00±0.25	X'±3'	DESIGNER	Han_Gao	21.10.12	TITLE: Pitch2.00mm MX双排带扣Housing 无logo		
			SIZE: A4	0.000±0.10	X'X' ±2'	DRAWN	Zijun_Huang	21.10.12	REV: AO	SHEET: 2/3	

The product using material and processing must conform to the "WI-PZ-001"HSF technical standard control requirements

RoHS+HF

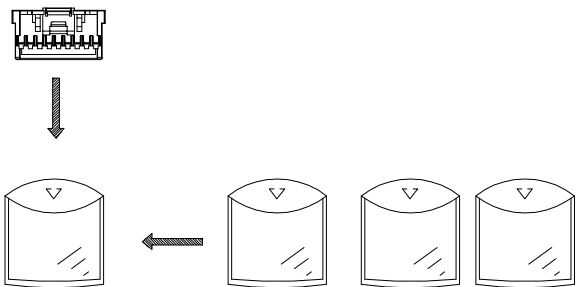

1. 纸箱装箱以不超过装箱线为准, 空余位置用塑料泡沫及保尼龙填充;
2. 因生产Pin位未齐全, 每袋与整箱包装数量仅供参考, 具体包装数量以实际出货为准, 或批量出货更新后为准:

PIN 位	包装数量 (KPCS)
(2*02~2*05P)	2000PCS/BAG
(2*06~2*10P)	1000PCS/BAG
(2*11~2*20P)	500PCS/BAG

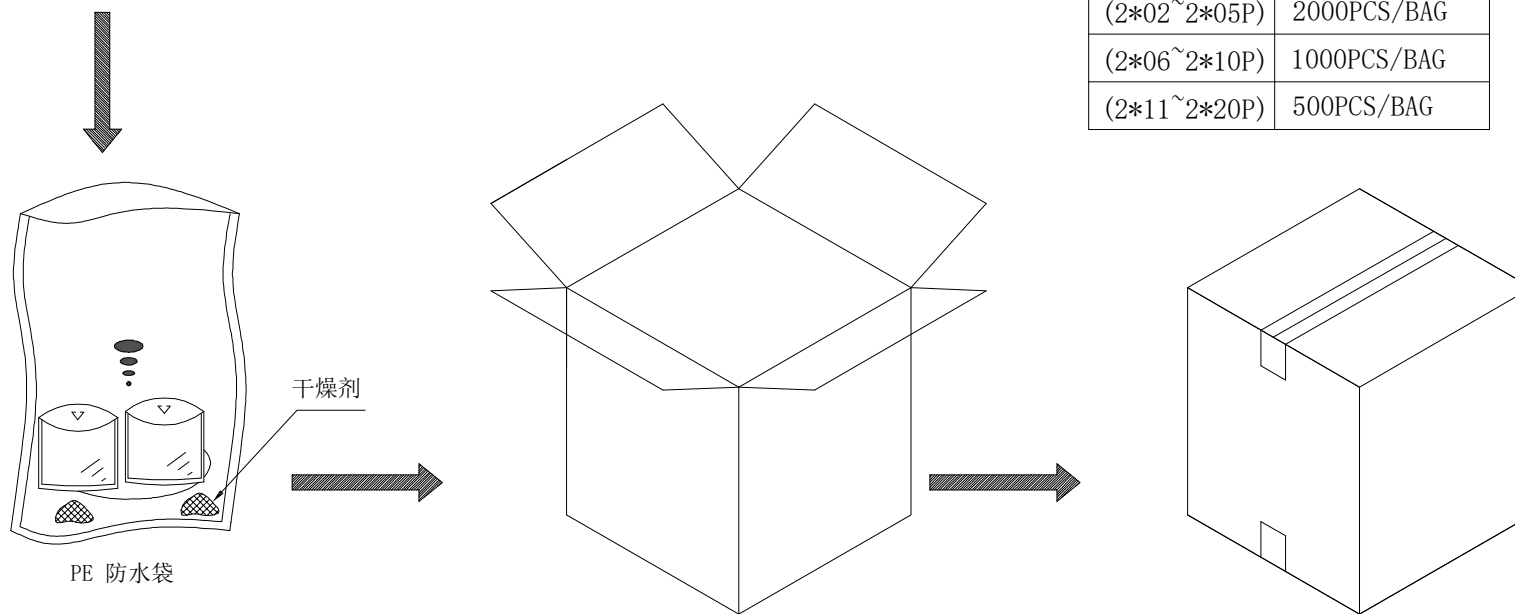

REV.	REVISION RECORD	DATE		GENERAL TOLERANCES		SCALE: 1:1	NAME	DATE	PART.NO:	DWG.NO:	 WanLian Technology Co., Ltd	
AO	NEW RELEASE	21.10.12		LINEAR	ANGLES	APPROVED	Wang_jr	21.10.12	A2036HM-2XXX0	ENDE05		
			0.0±0.35	X'REF±6°	DESIGNER	Han_Gao	21.10.12	TITLE:				
			UNIT: mm	0.00±0.25	X'±3°	DRAWN	Zijun_Huang	21.10.12	Pitch2.00mm MX双排带扣Housing 无logo			
			SIZE: A4	0.000±0.10	X'X' ±2'						REV: AO	SHEET: 3/3