

The product using material and processing must conform to the "WI-PZ-001"HSF technical standard control requirements

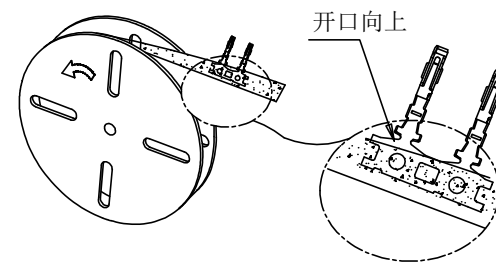

- NOTE:
- MATERIAL SPECIFICATION:  
1-1.TERMINAL: PHOSPHOR BRONZE
  - PLATING SPECIFICATION:  
2-1.TERMINAL:  
TIN/GOLD FLASH PLATED OVER ALL.
  - ELECTRICAL PERFORMANCE:  
3-1.CURRENT RATING: 2.0A AC/DC  
3-2.CONTACT RESISTANCE: 20 mΩ MAX  
3-3.INSULATION RESISTANCE: 1000MΩ Min  
3-4.DIELECTRIC WITHSTANDING : 1000V
  - ENVIRONMENTAL PERFORMANCE:  
4-1.OPERATING TEMPERATURE: -25°C~+85°C.
  - PACKAGE SPEC: REEL
  - P/N:

SERIES NO: A2036 T F X-X  
CONNECTOR: T-TERMINAL  
MALE FEMALE: F-FEMALE  
PLATING:  
A-ALL AU G/F  
C-BRIGHT TIN  
D-MATTE TIN  
METAL:  
P-PHOSPHOR BRONZE  
B-BRASS



Ordering Information & Specifications

Wire Range	Insulation O.D.	Qty/reel
AWG#22-#28	1.50mm(max)	10,000pcs

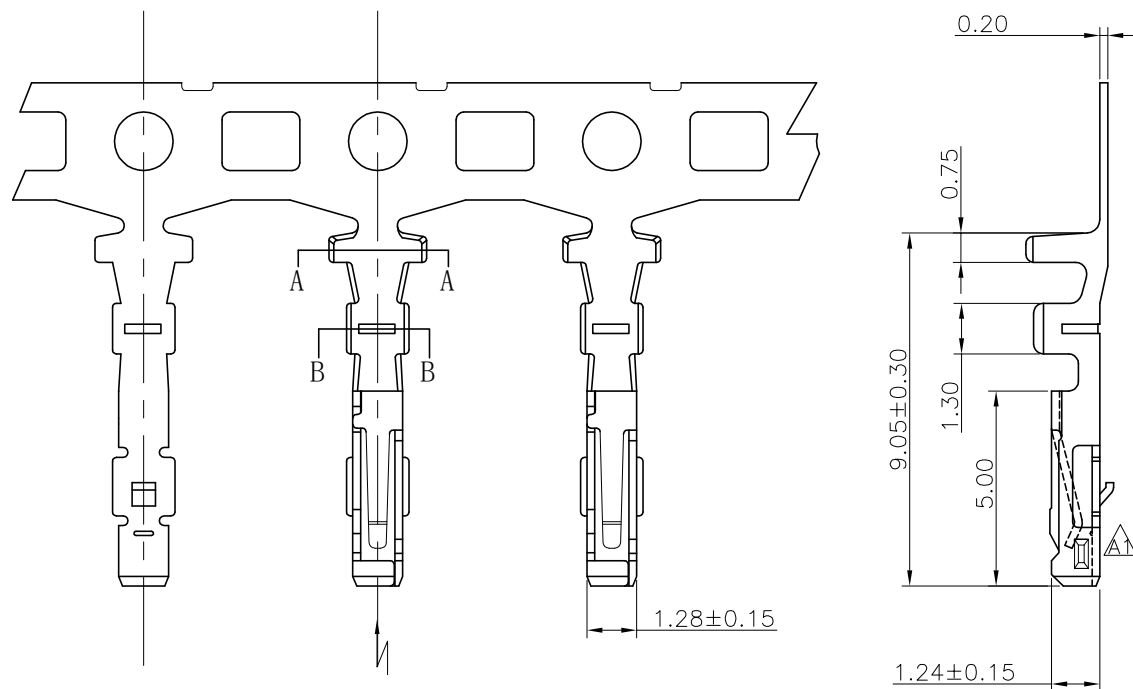

K direction

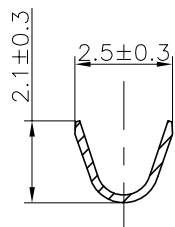

SECTION:A-A

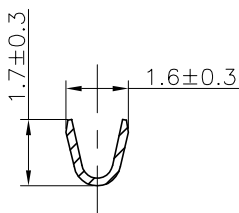

SECTION:B-B

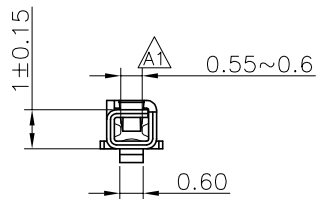

K direction

REV.	REVISION RECORD	DATE	GENERAL TOLERANCES		SCALE:	NAME	DATE	PART.NO:	DWG.NO:	 WanLian Technology Co., Ltd REV: A2 SHEET: 1/1
A0	NEW RELEASE	21.10.12	LINEAR	ANGLES	1:1			A2036TFX-X	ENDE05	
A1	Modify structure	22.09.16	0.0±0.35	X'REF±6'	APPROVED	Wang_jr	22.11.22			
A2	变更料号	22.11.22	0.00±0.25	X'±3'	DESIGNER	Han_Gao	22.11.22	TITLE:		
			0.000±0.10	X'X' ±2'	DRAWN	LX_HOU	22.11.22	Pitch2.00mm Crimp Terminal No Mark		