

The product using material and processing must conform to the "WI-PZ-001"HSF technical standard control requirements

RoHS+HF

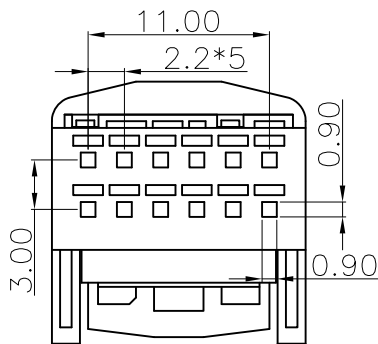
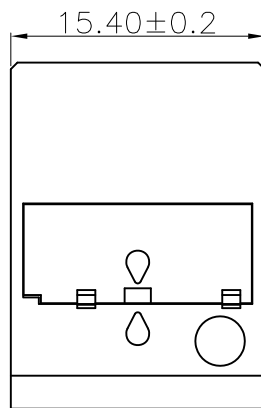
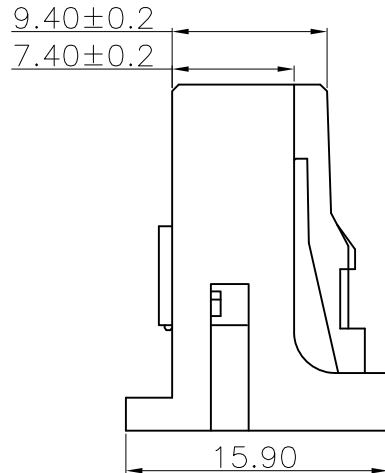
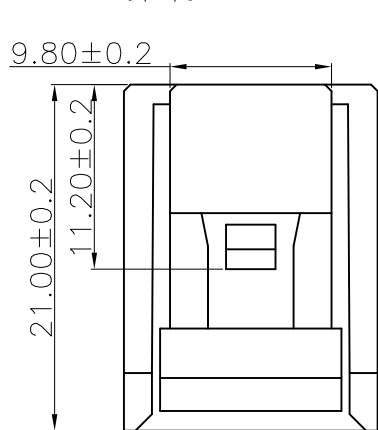
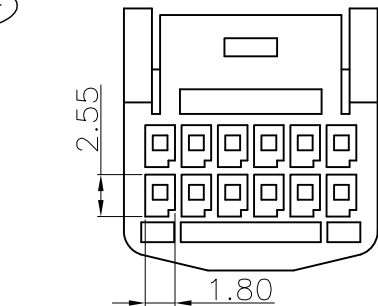

NOTE:

- 1.MATERIAL SPECIFICATION:
 - 1-1.HOUSING:PBT,UL94V-0
- 2.MECHANICAL PERFORMANCE:
 - 2-1.INSERTION FORCE: 1KGF/PIN MAX
 - 2-2.REMOVAL FORCE: 3KGF/PIN MIN
 - 2-3.DURABILITY: 25 CYCLES.
- 3.ELECTRICAL PERFORMANCE:
 - 3-1. RATED CURRENT : 10A
RATED VOLTAGE : 250V
 - 3-2.INSULATION RESISTANCE: 1000MΩ MIN
CONTACT RESISTANCE : 30mΩ MAX
 - 3-3.WITHSTANDING VOLTAGE:1500V AC
- 4.ENVIRONMENTAL PERFORMANCE:
 - OPERATING TEMPERATURE: -40°C~+90°C.
- 5.PACKAGE SPEC:PE BAG
- 6.P/N:

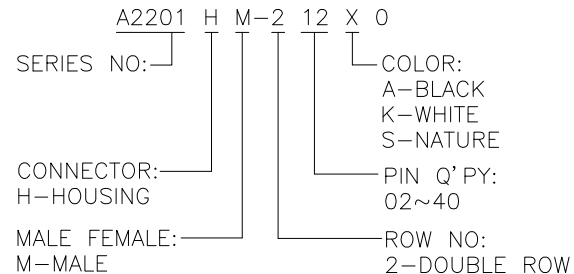

REV.	REVISION RECORD	DATE	GENERAL TOLERANCES		SCALE:	NAME	DATE	PART.NO:	DWG.NO:	 WanLian Teconology Co., Ltd
A0	NEW RELEASE	21.01.13	 UNIT:mm SIZE: A4	LINEAR	1:1	Wang_jr	21.01.13	A2201HM-212X0	ENDE05	
				0.0±0.35	ANGLES	APPROVED	Han_Gao	21.01.13	TITLE:	
			0.00±0.25	X°REF±6°	DESIGNER	Zijun_Huang	21.01.13	PITCH 2.20mm 公胶壳		REV: A0
			0.000±0.10	X°X' ±2°	DRAWN					SHEET: 1/1