

The product using material and processing must conform to the "WI-PZ-001" HSF technical standard control requirements

RoHS+HF

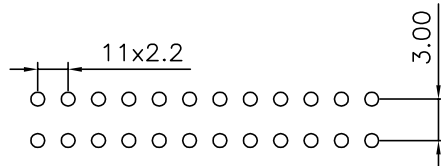

P.C.B LAYOUT

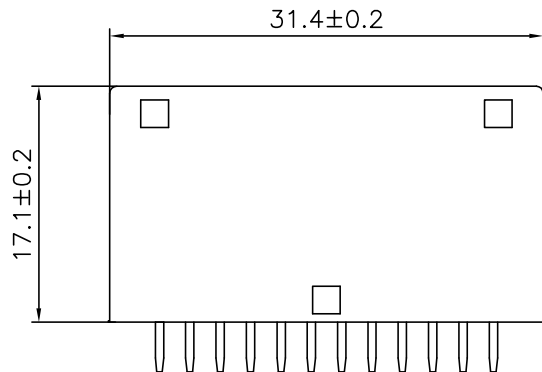
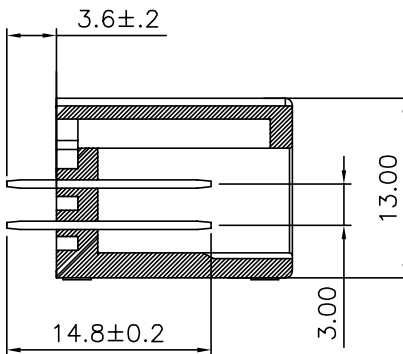
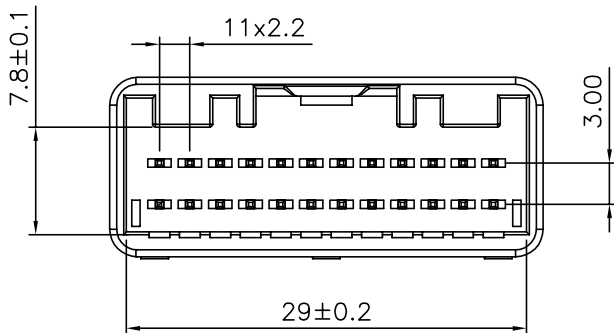

NOTE:

- 1.MATERIAL SPECIFICATION:
 - 1-1.HOUSING: PA66,UL94V-0
 - 1-2.CONTACTS: Brsss H62
- 2.PLATING SPECIFICATION:
 - 2-1.CONTACTS: TIN/GOLD FLASH PLATED OVER ALL.
- 3.MECHANICAL PERFORMANCE:
 - 3-1.RETENTIVITY FORCE: 3.5KGF/pin min
 - 3-2.DURABILITY: 50 CYCLES.
- 4.ELECTRICAL PERFORMANCE:
 - 4-1.CURRENT RATING: 10A AC/DC
 - 4-2.CONTACT RESISTANCE: 30 mΩ MAX
 - 4-3.INSULATION RESISTANCE: 1000MΩ Min
 - 4-4.DIELECTRIC WITHSTANDING : 1500V
- 5.ENVIRONMENTAL PERFORMANCE:
 - 5-1.OPERATING TEMPERATURE: -40°C~+90°C.
- 6.PACKAGE SPEC: TRAY
- 7.P/N:

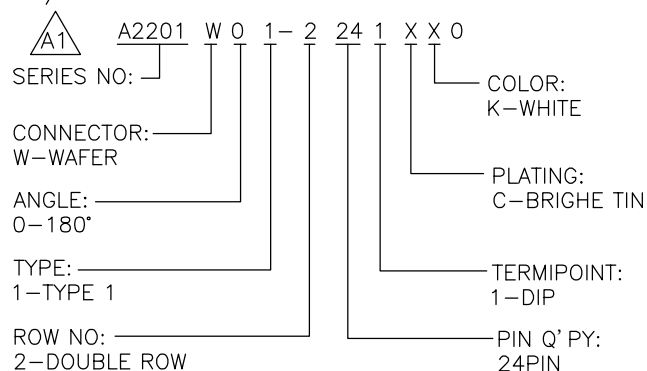

REV.	REVISION RECORD	DATE	UNIT:mm	GENERAL TOLERANCES		SCALE:	NAME	DATE	PART.NO:	DWG.NO:	 WanLian Technology Co., Ltd
A0	NEW RELEASE	21.11.17		LINEAR	ANGLES	1:1	APPROVED	Wang_jr			
A1	PART NUMBER RENEWAL	23.10.07	0.00±0.25	X'±3'		DESIGNER	Han_Gao	23.10.07	A2201W01-2241XX0 ENDE05 TITLE: Pitch 2.20mm 180° 立插带扣 全平短体直针汽车连接器	REV: A1	SHEET: 1/1
			0.00±0.35	X'REF±6'		DRAWN	Zijun_Huang	23.10.07			