

The product using material and processing must conform to the "WI-PZ-001" HSF technical standard control requirements

RoHS+HF

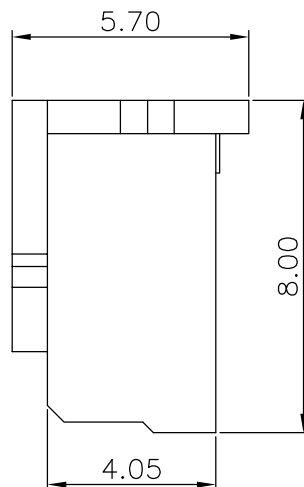
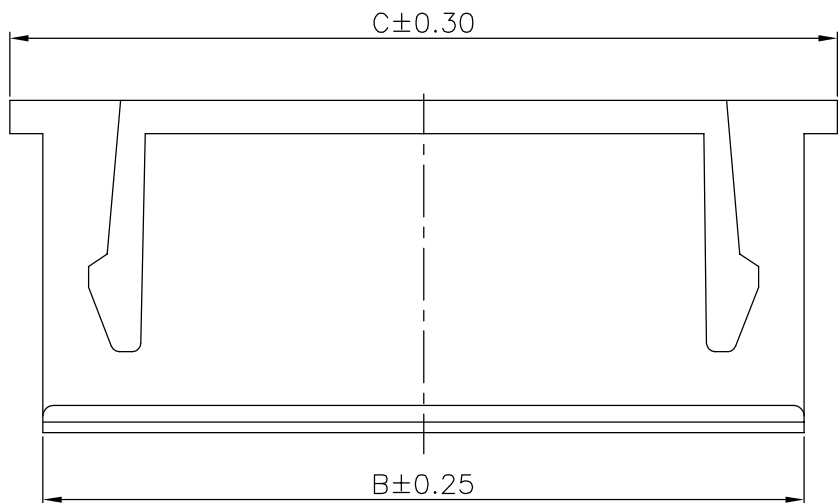

NOTE:

- 1.MATERIAL SPECIFICATION:  
1-1.HOUSING: PA66,UL94V-0
- 2.ELECTRICAL PERFORMANCE:  
2-1.INSULATION RESISTANCE: 1000MΩ Min  
2-2.DIELECTRIC WITHSTANDING : 1000V
- 3.ENVIRONMENTAL PERFORMANCE:  
3-1.OPERATING TEMPERATURE: -25°C~+85°C.
- 4.PACKAGE SPEC: PE BAG
- 5.P/N:

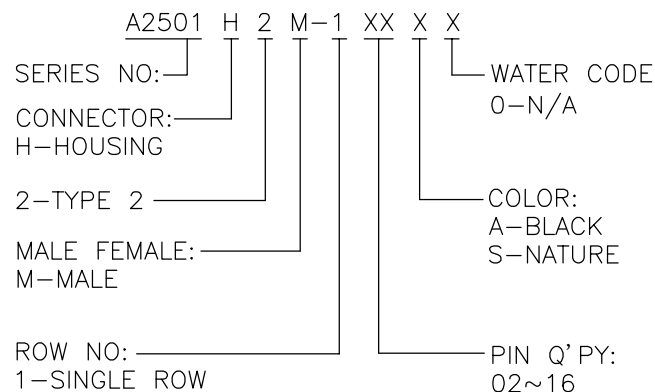

Ordering Information & Dimensions

Circuit	Dimensions(mm)			Circuit	Dimensions(mm)		
	A	B	C		A	B	C
02	2.50	5.70	7.30	10	22.50	25.70	27.30
03	5.00	8.20	9.80	11	25.00	28.20	29.80
04	7.50	10.70	12.30	12	27.50	30.70	32.30
05	10.00	13.20	14.80	13	30.00	33.20	34.80
06	12.50	15.70	17.30	14	32.50	35.70	37.30
07	15.00	18.20	19.80	15	35.00	38.20	39.80
08	17.50	20.70	22.30	16	37.50	40.70	42.30
09	20.00	23.20	24.80				

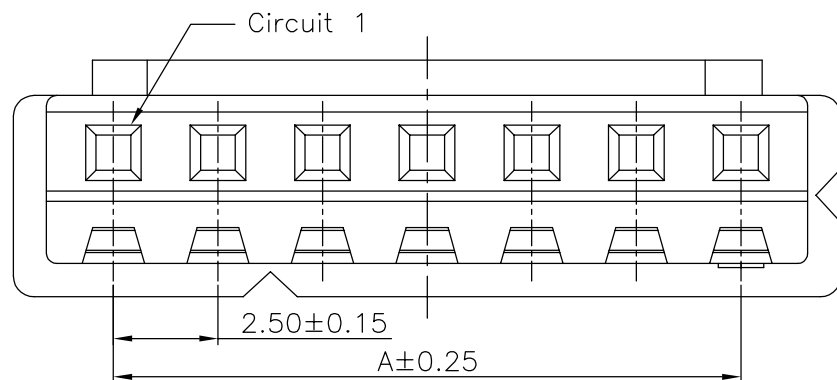

REV.	REVISION RECORD	DATE	UNIT:mm	GENERAL TOLERANCES		SCALE:	NAME	DATE	PART.NO:	DWG.NO:	 WanLian Technology Co., Ltd
A0	NEW RELEASE	22.09.08		0.00±0.25	LINEAR	ANGLES	1:1	Wang_jr	22.09.08	A2501H2M-1XXXX	
			0.00±0.10	0.00±0.35	X'REF±6'		Han_Gao	22.09.08	TITLE:		REV: A0
			SIZE: A4	0.000±0.10	X'X' ±2'		LanXuan_Hou	22.09.08	Pitch 2.50mm 180°XH MALE HOUSING		SHEET: 1/3

# PIN位示意图

The product using material and processing must conform to the "WI-PZ-001" HSF technical standard control requirements

RoHS+HF

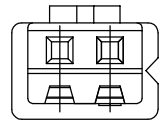

2P

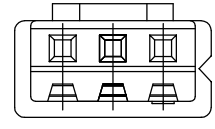

3P

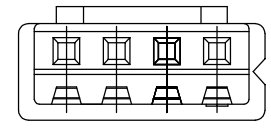

4P

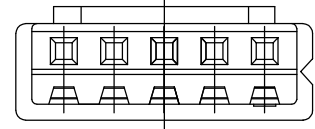

5P

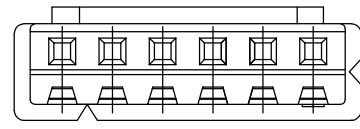

6P

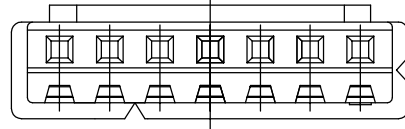

7P

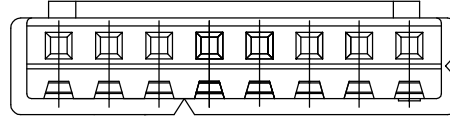

8P

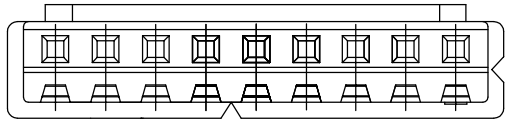

9P

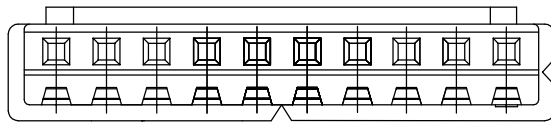

10P

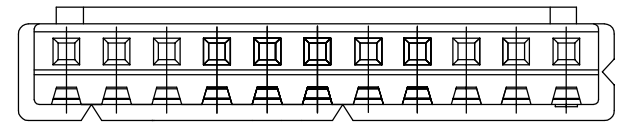

11P

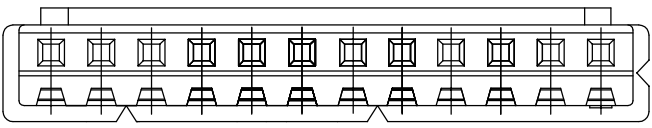

12P

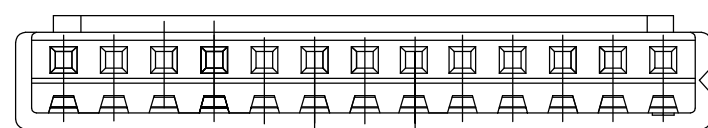

13P

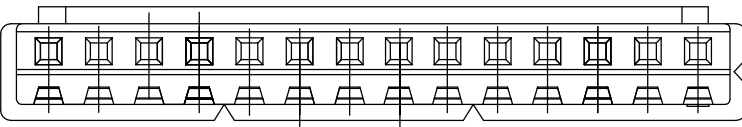

14P

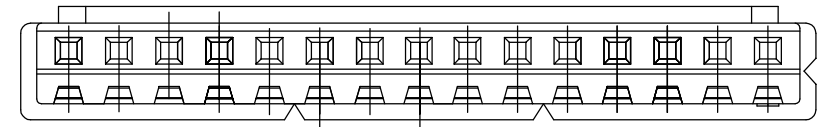

15P

REV.	REVISION RECORD	DATE		GENERAL TOLERANCES		SCALE: 1:1	NAME	DATE	PART.NO:	DWG.NO:	 WanLian Technology Co., Ltd
AO	NEW RELEASE	22.09.08		LINEAR	ANGLES	APPROVED	Wang_jr	22.09.08	A2501H2M-1XXXX	ENDE05	
			UNIT:mm	0.00±0.25	X'±3'	DESIGNER	Han_Gao	22.09.08	TITLE:		REV: A0
			SIZE: A4	0.000±0.10	X'X' ±2'	DRAWN	LanXuan_Hou	22.09.08	Pitch 2.50mm 180°XH MALE HOUSING		

