

The product using material and processing must conform to the "WI-PZ-001" HSF technical standard control requirements

RoHS

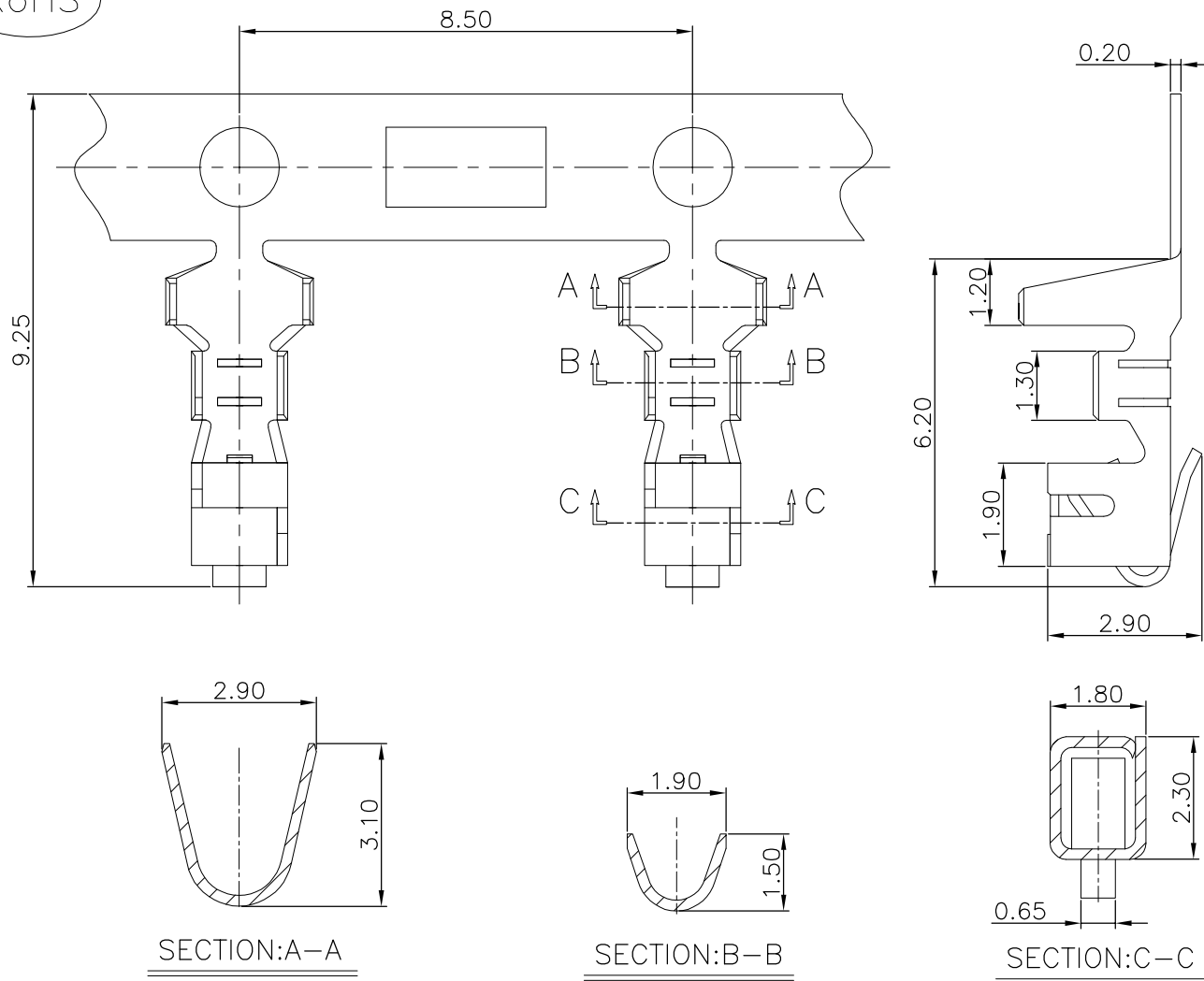

NOTE:
 1.MATERIAL SPECIFICATION:
 1-1.CONTACTS: PHOSPHOR BRONZE
 2.PLATING SPECIFICATION:
 2-1.CONTACTS:
 TIN/GOLD FLASH PLATED OVER ALL.
 3.ELECTRICAL PERFORMANCE:
 3-1.CURRENT RATING: 3A AC/DC
 3-2.CONTACT RESISTANCE: 20 mΩ MAX
 3-3.INSULATION RESISTANCE: 1000MΩ Min
 3-4.DIELECTRIC WITHSTANDING : 1000V
 4.ENVIRONMENTAL PERFORMANCE:
 4-1.OPERATING TEMPERATURE: -25°C~+85°C.
 5.WIRE RANGE: AWG22#-28#
 6.P/N:

SERIES NO: A2501 T 2 F X-X
 CONNECTOR: T 2 F X-X
 2-TYPE 2
 MALE FEMALE: F-FEMALE
 PLATING:
 1-G/F
 A-ALL AU G/F
 C-BRIGHT TIN
 D-MATTE TIN
 METAL:
 P-PHOSPHOR BRONZE
 B-BRASS

REV.	REVISION RECORD	DATE		GENERAL TOLERANCES		SCALE: 1:1	NAME	DATE	PART.NO: A2501T2FX-X	DWG.NO: ENDE05	
AO	NEW RELEASE	22.09.08		LINEAR	ANGLES	APPROVED	Wang_jr	22.09.08			
			UNIT:mm	0.00±0.25	X'±3'	DESIGNER	Han_Gao	22.09.08	TITLE: Pitch 2.50mm 180°XH Female端子		
			SIZE: A4	0.000±0.10	X'X' ±2'	DRAWN	LanXuan_Hou	22.09.08			REV: A0 SHEET: 1/2

The product using material and processing must conform to the "WI-PZ-001" HSF technical standard control requirements

RoHS

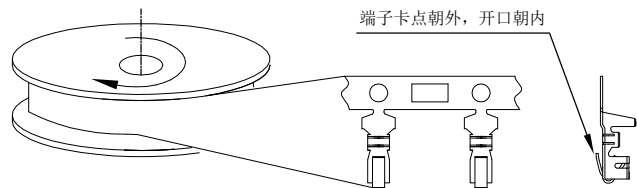

电镀后卷料方向

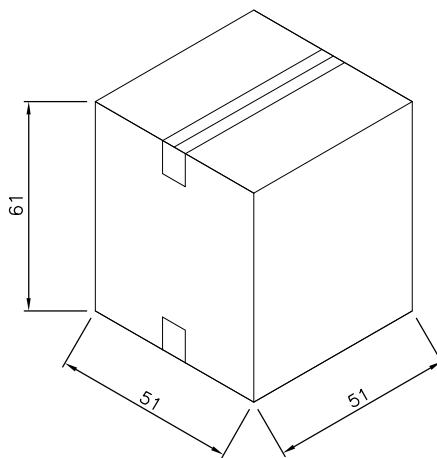
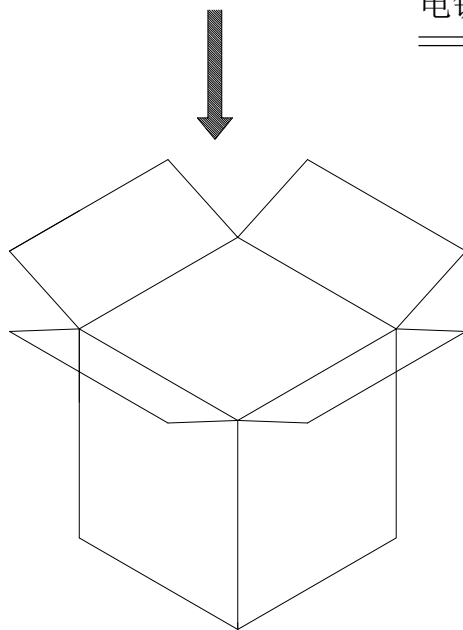

NOTE (注):

1. 纸箱装箱以不超过装箱线为准, 空余位置用塑料泡沫及保尼龙填充;

包装数量

6000PCS/REEL

REV.	REVISION RECORD	DATE		GENERAL TOLERANCES		SCALE: 1:1	NAME	DATE	PART.NO:	DWG.NO:	
A0	NEW RELEASE	22.09.08		<div style="display: flex; justify-content: space-between;"> <div> <p>UNIT:mm</p> <p>SIZE: A4</p> </div> <div> <p>LINEAR</p> <p>0.0±0.35</p> <p>0.00±0.25</p> <p>0.000±0.10</p> </div> <div> <p>ANGLES</p> <p>X°REF±6'</p> <p>X°±3'</p> <p>X°X'±2'</p> </div> </div>	APPROVED	Wang_jr	22.09.08	A2501T2FX-X	ENDE05	Pitch 2.50mm 180°XH Female端子	
			DESIGNER	Han_Gao	22.09.08	TITLE:					
			DRAWN	LanXuan_Hou	22.09.08						