

The product using material and processing must conform to the "WI-PZ-001"HSF technical standard control requirements

ROHS+HF

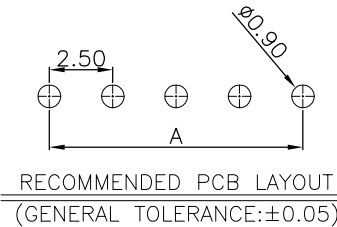
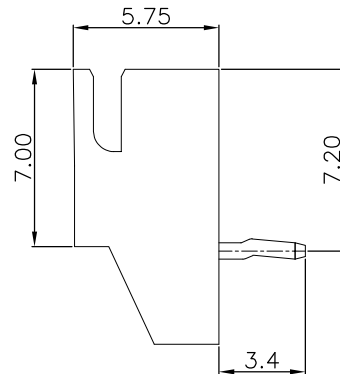
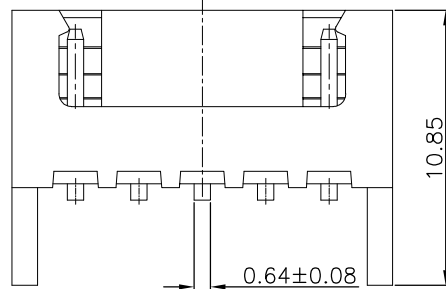
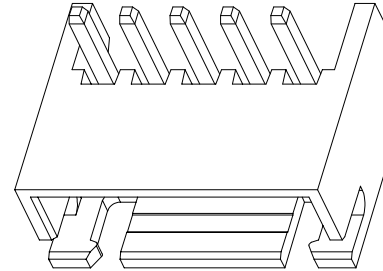
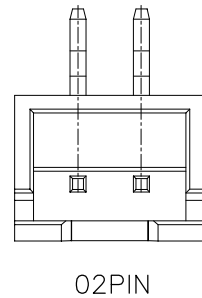
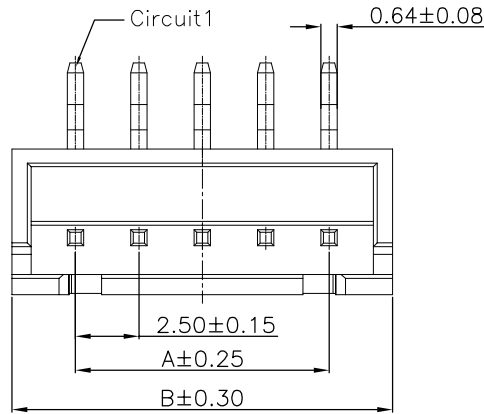

- NOTE:
- MATERIAL SPECIFICATION:
    - HOUSING: PA66,UL94V-0
    - CONTACTS: BRASS
  - PLATING SPECIFICATION:
    - CONTACTS: TIN/GOLD FLASH PLATED OVER ALL.
  - ELECTRICAL PERFORMANCE:
    - CURRENT RATING: 3.0A
    - CONTACT RESISTANCE: 20mΩ Max.
    - INSULATION RESISTANCE: 1000MΩ MIN
    - DIELECTRIC WITHSTANDING: 1000V AC Min
  - ENVIRONMENTAL PERFORMANCE:
    - OPERATING TEMPERATURE: -25°C~+85°C.
  - PACKAGE SPEC: PE BAG
  - P/N ORDER:

SERIES NO: A2501 W 9 5-1 XX 1 X X X  
 CONNECTOR: W-WAFER  
 ANGLE: 9-90°  
 TYPE: 5-TYPE 5  
 ROW NO: 1-SINGLE ROW  
 PIN Q'PY: 02~16

CHARACTERISTIC: 1-PLAY K  
 COLOR: A-BLACK K-WHITE  
 PLATING: A-ALL AU G/F C-BRIGHE TIN D-MATTE Tin  
 TERMIPOINT: 1-DIP

Circuits	Dimensions(mm)		Circuits	Dimensions(mm)	
	A	B		A	B
02	2.50	7.50	10	22.50	27.50
03	5.00	10.00	11	25.00	30.00
04	7.50	12.50	12	27.50	32.50
05	10.00	15.00	13	30.00	35.00
06	12.50	17.50	14	32.50	37.50
07	15.00	20.00	15	35.00	40.00
08	17.50	22.50	16	37.50	42.50
09	20.00	25.00			

REV.	REVISION RECORD	DATE	GENERAL TOLERANCES		SCALE:	NAME	DATE	PART.NO:	DWG.NO:	 WanLian Technology Co., Ltd
A0	NEW RELEASE	23.04.18	LINEAR	ANGLES	1:1	Wang_jr	23.04.18	A2501W95-1XX1XXX	ENDE05	
			0.0±0.35	X'REF±6'	APPROVED	Han_Gao	23.04.18	TITLE:		
			UNIT:mm	X'±3'	DESIGNER	LX_HOU	23.04.18	Pitch 2.50mm 90°XH WAFER 带定位 打K		
			SIZE: A4	0.000±0.10	X'X' ±2'	DRAWN				REV: A0 SHEET: 1/2

The product using material and processing must conform to the "WI-PZ-001"HSF technical standard control requirements

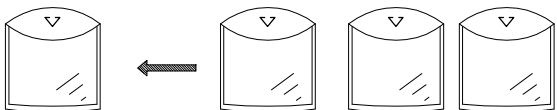

PE袋 1 Pcs  
数量 :每袋=0.4~2Kpcs

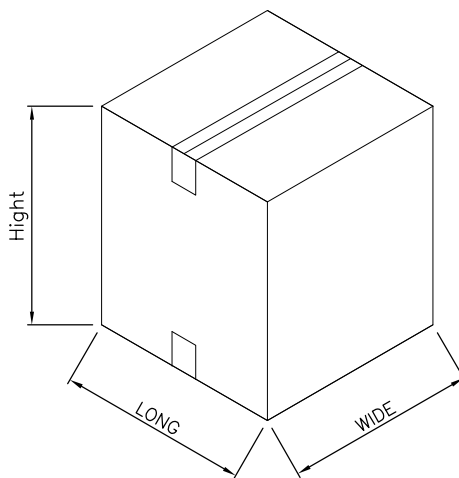
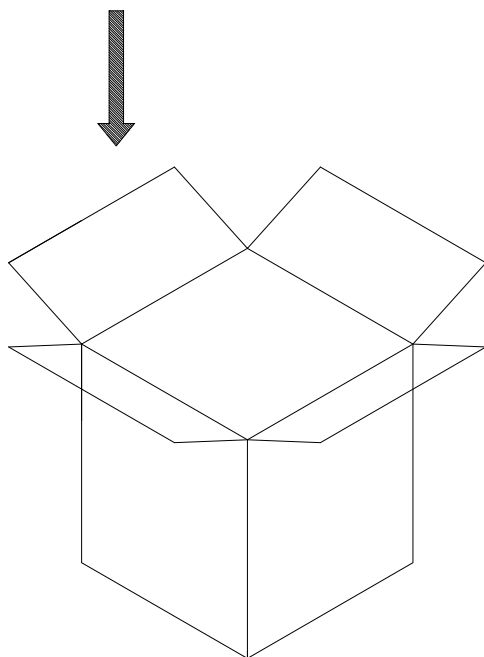

NOTE(注):

1. 纸箱装箱以不超过装箱线为准,空余位置用塑料泡沫及保尼龙填充;
2. 纸箱分小、中、标准型、大4种规格型号: 装箱为整箱(左下包装量)采用大型纸箱包装, 未达到整箱数量以产品量适当采用小型、中型或标准型纸箱包装;
3. 因生产Pin位未齐全, 每袋与整箱包装数量仅供参考, 具体包装数量以实际出货为准, 或批量出货更新后为准;

纸箱型号 Carton Type	小型 Small Size	中型 Medium	标准型 Standard	大型 Large
长度 Long (CM)	35	35	35	46
宽度 Wide (CM)	35	35	35	46
高度 Hight (CM)	7.5	15	32	46

袋装包装数量

CKT	PCS/BAG
2	2000
3	2000
4	2000
5	1000
6	1000
7	1000
8	1000
9	500
10	500
11	500
12	500
13	500
14	500
15	400
16	400

REV.	REVISION RECORD	DATE		GENERAL TOLERANCES		SCALE: 1:1	NAME	DATE	PART.NO:	DWG.NO:	 WanLian Technology Co., Ltd	
AO	NEW RELEASE	23.04.18		LINEAR 0.0±0.35 UNIT:mm SIZE: A4	ANGLES X°REF±6' X'±3' X°X'±2'	APPROVED	Wang_jr	23.04.18	A2501W95-1XX1XXX	ENDE05		TITLE: Pitch 2.50mm 90°XH WAFER 带定位 打K
					DESIGNER	Han_Gao	23.04.18					
					DRAWN	LX_HOU	23.04.18					