

The product using material and processing must conform to the "WI-PZ-001" HSF technical standard control requirements

RoHS

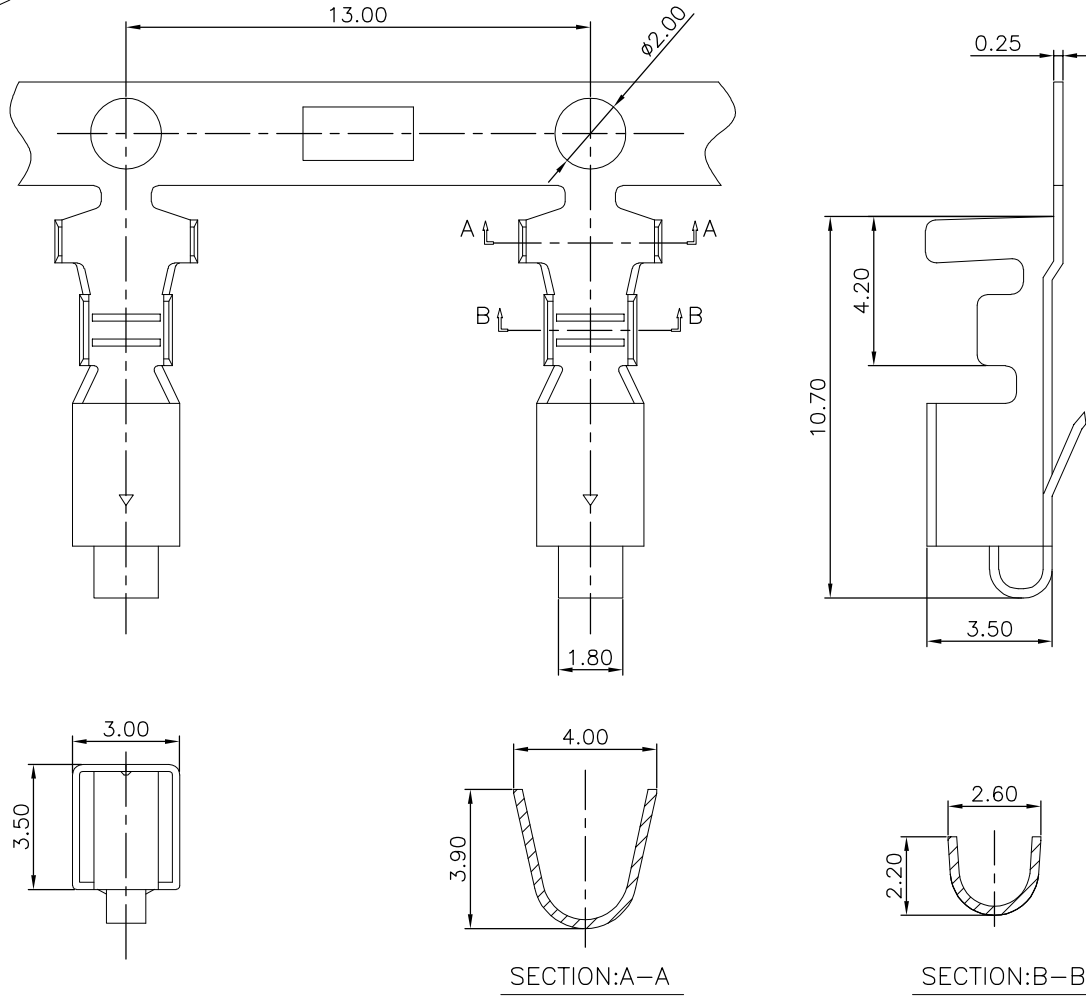

NOTE:

- 1.MATERIAL SPECIFICATION:
1-1.TERMINAL: PHOSPHOR BRONZE
- 2.PLATING SPECIFICATION:
2-1.TERMINAL:
TIN/GOLD FLASH PLATED OVER ALL.
- 3.ELECTRICAL PERFORMANCE:
3-1.CURRENT RATING: 7A
3-2.CONTACT RESISTANCE: 20 mΩ MAX
3-3.INSULATION RESISTANCE: 1000MΩ Min
3-4.DIELECTRIC WITHSTANDING : 1500V AC
- 4.ENVIRONMENTAL PERFORMANCE:
4-1.OPERATING TEMPERATURE: -25°C~+85°C.
- 5.PACKAGE SPEC : REEL
- 6.WIRE RANGE:AWG 18#~22#
- 7.P/N: A3962 T 4 F X-X

SERIES NO:



CONNECTOR:
T-TERMINAL

TYPE CODE

PLATING:
C-BRIGHT TIN

METAL:
P-PHOSPHOR BRONZE

MALE FEMALE:
F-FEMALE

REV.	REVISION RECORD	DATE	GENERAL TOLERANCES		SCALE:	NAME	DATE	PART.NO:	DWG.NO:	 WanLian Technology Co., Ltd
A0	NEW RELEASE	22.03.19	 LINEAR 0.0±0.35 0.00±0.25 SIZE: A4	ANGLES X'REF±6° X'±3° X'X' ±2°	1:1	Wang_jr	22.03.19	A3962T4FX-X	ENDE05	
					CHECK	XueZe_Ma	22.03.19	TITLE: Pitch 3.96mm 180°VH Female端子 AWG 18#~22#		REV: A0
			DRAWN	LanXuan_Hou	22.03.19					

The product using material and processing must conform to the "WI-PZ-001" HSF technical standard control requirements

RoHS

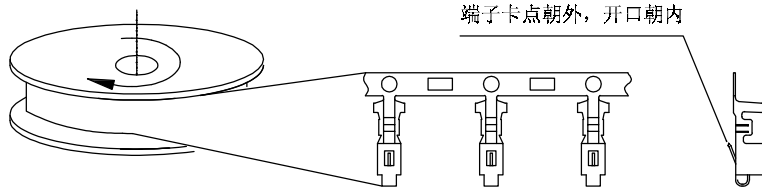

端子卡点朝外，开口朝内

1. 纸箱装箱以不超过装箱线为准，空余位置用塑料泡沫及保尼龙填充；

PCS/REEL	REEL/CARTON	LARGE SUM(PCS)
3000	22	66000

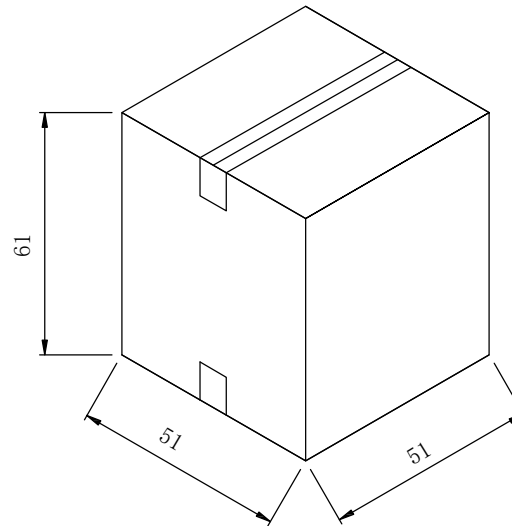
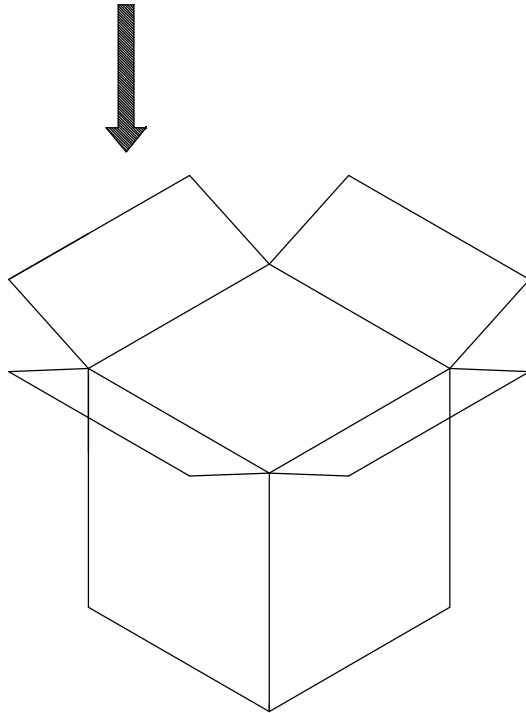

REV.	REVISION RECORD	DATE		GENERAL TOLERANCES		SCALE: 1:1	NAME	DATE	PART.NO:	DWG.NO:	
AO	NEW RELEASE	22.03.19		LINEAR	ANGLES	APPROVED	Wang_jr	22.03.19	A3962T4FX-X	ENDE05	
			0.0±0.35	X°REF±6°	CHECK	XueZe_Ma	22.03.19	TITLE:		REV: A0 SHEET: 2/2	
			0.00±0.25	X°±3°	DRAWN	LanXuan_Hou	22.03.19	Pitch 3.96mm 180°VH Female端子 AWG 18#~22#			
			UNIT:mm	X°X' ±2°							
			SIZE: A4	0.000±0.10							