

The product using material and processing must conform to the "WI-PZ-001" HSF technical standard control requirements

RoHS+HF

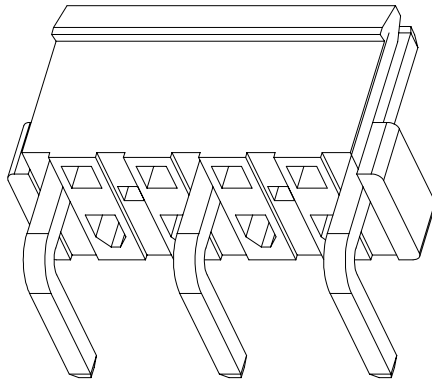

- NOTE:
- MATERIAL SPECIFICATION:
    - HOUSING: PA66,UL94V-0
    - CONTACTS: BRASS
  - PLATING SPECIFICATION:
    - CONTACTS: TIN/GOLD FLASH PLATED OVER ALL.
  - ELECTRICAL PERFORMANCE:
    - CURRENT RATING: 7A AC/DC
    - CONTACT RESISTANCE: 20 mΩ MAX
    - INSULATION RESISTANCE: 1000MΩ Min
    - DIELECTRIC WITHSTANDING : 1500V
  - ENVIRONMENTAL PERFORMANCE:
    - OPERATING TEMPERATURE: -25°C~+85°C.
  - PACKAGE SPEC: PE BAG
  - P/N:

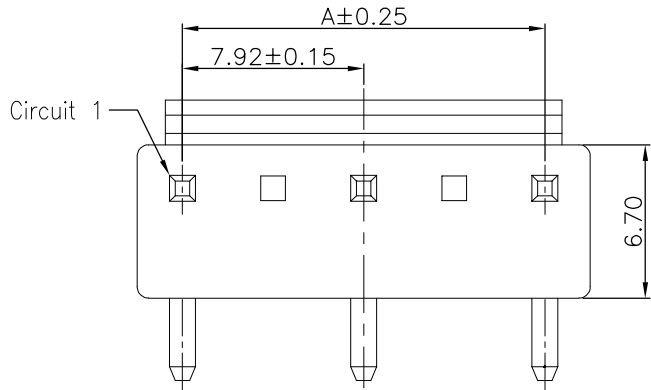
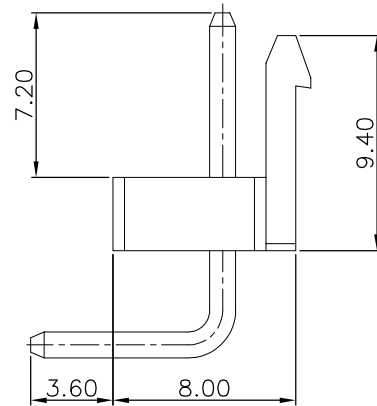
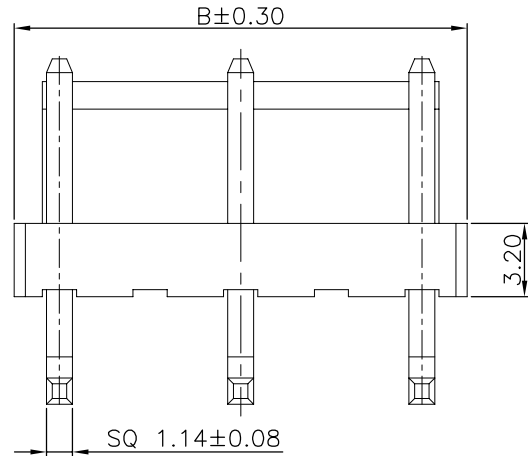

SERIES NO: A3962 W 9 C-1 XX 1 X X X

CONNECTOR: W-WAFER

ANGLE: 9-90°

TYPE: C-TYPE C

ROW NO: 1-SINGLE ROW

PIN Q'PY: 03~15

WATER CODE: 0-N/A

COLOR: S-NATURE

PLATING: C-BRIGHE TIN

TERMIPOINT: 1-DIP

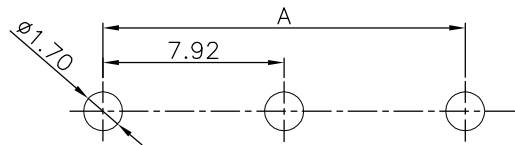

RECOMMENDED PCB LAYOUT  
(GENERAL TOLERANCE:±0.05)

备注:  
空偶数PIN位:  
03Pin空第2Pin  
05Pin空第2、4Pin  
07Pin空第2、4、6Pin  
.....

Ordering Information & Dimensions

Circuit	Dimensions(mm)	
	A	B
03	7.92	11.88
05	15.84	19.80
07	23.76	27.72
09	31.68	35.64
11	39.60	43.56
13	47.52	51.48
15	55.44	59.40

REV.	REVISION RECORD	DATE	UNIT:mm	GENERAL TOLERANCES		SCALE: 1:1	NAME	DATE	PART.NO:	DWG.NO:	REV: A0	SHEET: 1/2
A0	NEW RELEASE	22.03.19		LINEAR	ANGLES	APPROVED	Wang_jr	22.03.19	A3962W9C-1XX1XXX	ENDE05		
			0.00±0.25	X'±3'	CHECK	XueZe_Ma	22.03.19	TITLE:				
			SIZE: A4	0.000±0.10	X'X' ±2'	DRAWN	LanXuan_Hou	22.03.19	Pitch 3.96mm 90° 高弯 单排卧插 空偶数PIN 直背 Wafer			



WanLian Technology Co., Ltd

The product using material and processing must conform to the "WI-PZ-001" HSF technical standard control requirements

RoHS+HF

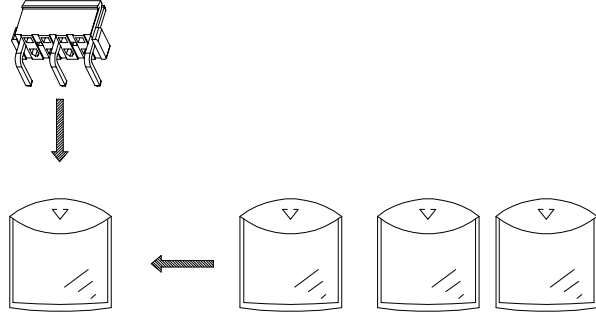

PE袋 1 Pcs  
数量 : 每袋=0.3~2Kpcs

1. 纸箱装箱以不超过装箱线为准, 空余位置用塑料泡沫及保尼龙填充;
2. 纸箱分小、中、标准型、大4种规格型号: 装箱为整箱采用大型纸箱包装, 未达到整箱数量以产品量适当采用小型、中型或标准型纸箱包装;
3. 因生产Pin位未齐全, 每袋与整箱包装数量仅供参考, 具体包装数量以实际出货为准, 或批量出货更新后为准;

纸箱型号 Carton Type	小型 Small Size	中型 Medium	标准型 Standard	大型 Large
长度 Long (CM)	35	35	35	46
宽度 Wide (CM)	35	35	35	46
高度 Hight (CM)	7.5	15	32	46

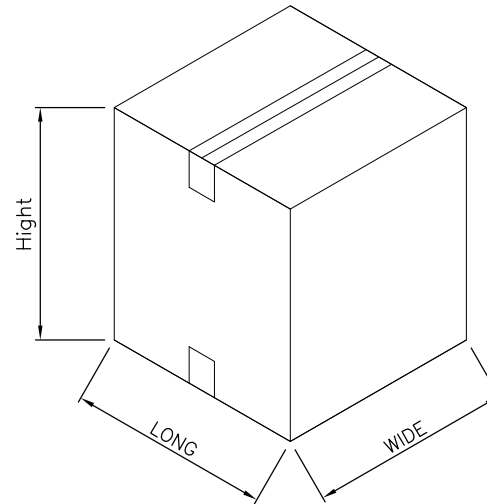
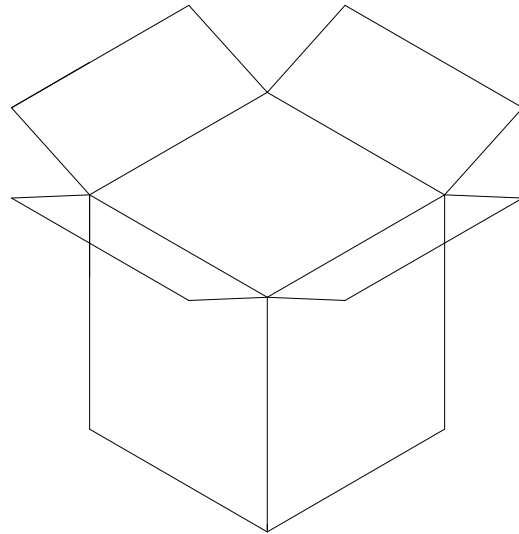

袋装包装数量	
CKT	PCS/BAG
2	2000
3	1000
4	1000
5	500
6	500
7	500
8	500
9	300
10	300
11	300
12	300
13	300
14	300
15	300
16	300

REV.	REVISION RECORD	DATE		GENERAL TOLERANCES		SCALE: 1:1	NAME	DATE	PART.NO:	DWG.NO:	
AO	NEW RELEASE	22.03.19		LINEAR	ANGLES	APPROVED	Wang_jr	22.03.19	A3962W9C-1XX1XXX	ENDE05	
			0.0±0.35	X°REF±6'	CHECK	XueZe_Ma	22.03.19	TITLE:		Pitch 3.96mm 90° 高弯 单排卧插 空偶数PIN 直背 Wafer REV: A0 SHEET: 2/2	
			UNIT:mm	X'±3'	DRAWN	LanXuan_Hou	22.03.19				
			SIZE: A4	0.000±0.10	X'X' ±2'						